

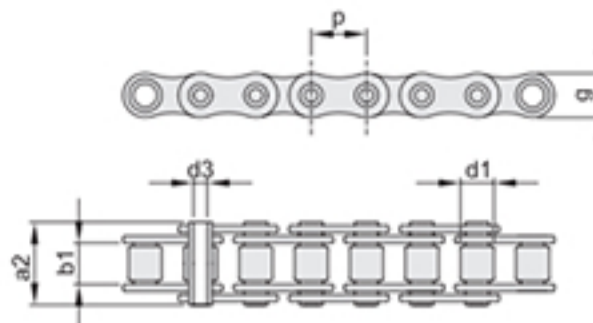

Роликовая цепь с полыми валиками - DIN 8187 - ISO 606

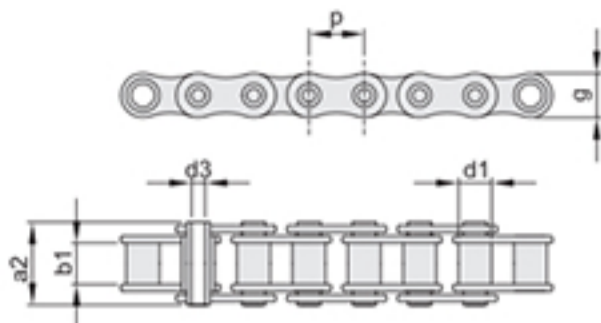

TIPO A - A BUSSOLA

TIPO B - A RULLI

CATENA PRODOTTA DA AZIENDA CERTIFICATA ISO 9001/2000 - ISO 14001 E API 7F
CHAIN PRODUCED BY ISO 9001/2000 - ISO 14001 AND API 7F CERTIFIED COMPANY



CATENA PRESTIRATA / PRE-STRETCHED CHAINS

ISO	p		b ₁ mm min.	d ₃ mm	d ₁ mm max.	a ₂ mm max.	g mm max.	Carico di rottura		q kg/m	TIPO
	mm	inch						minimo KN	medio KN		
08B-1	12,7	1/2"	7,75	4,50	8,51	17,0	11,6	9,3	12,8	0,58	A
10B-1	15,875	5/8"	9,65	5,18	10,16	19,6	14,7	12,7	16,4	0,73	A
10A-1	15,875	5/8"	9,53	5,18	10,16	20,5	14,7	18,1	19,9	0,85	A
12B-1	19,05	3/4"	11,68	5,85	12,07	22,7	15,9	12,7	17,5	1,10	A
08B-1	12,7	1/2"	7,75	4,50	8,51	17,0	11,6	10,8	17,4	0,58	B
10B-1	15,875	5/8"	9,65	5,18	10,16	19,6	14,5	14,7	19,7	0,77	B
12B-1	19,05	3/4"	11,68	5,85	12,07	22,7	15,9	16,7	23,3	0,98	B
16B-1	25,4	1"	17,02	8,33	15,88	36,1	20,5	32,7	41,0	2,21	B