

SKF and PEER Agri Hub range

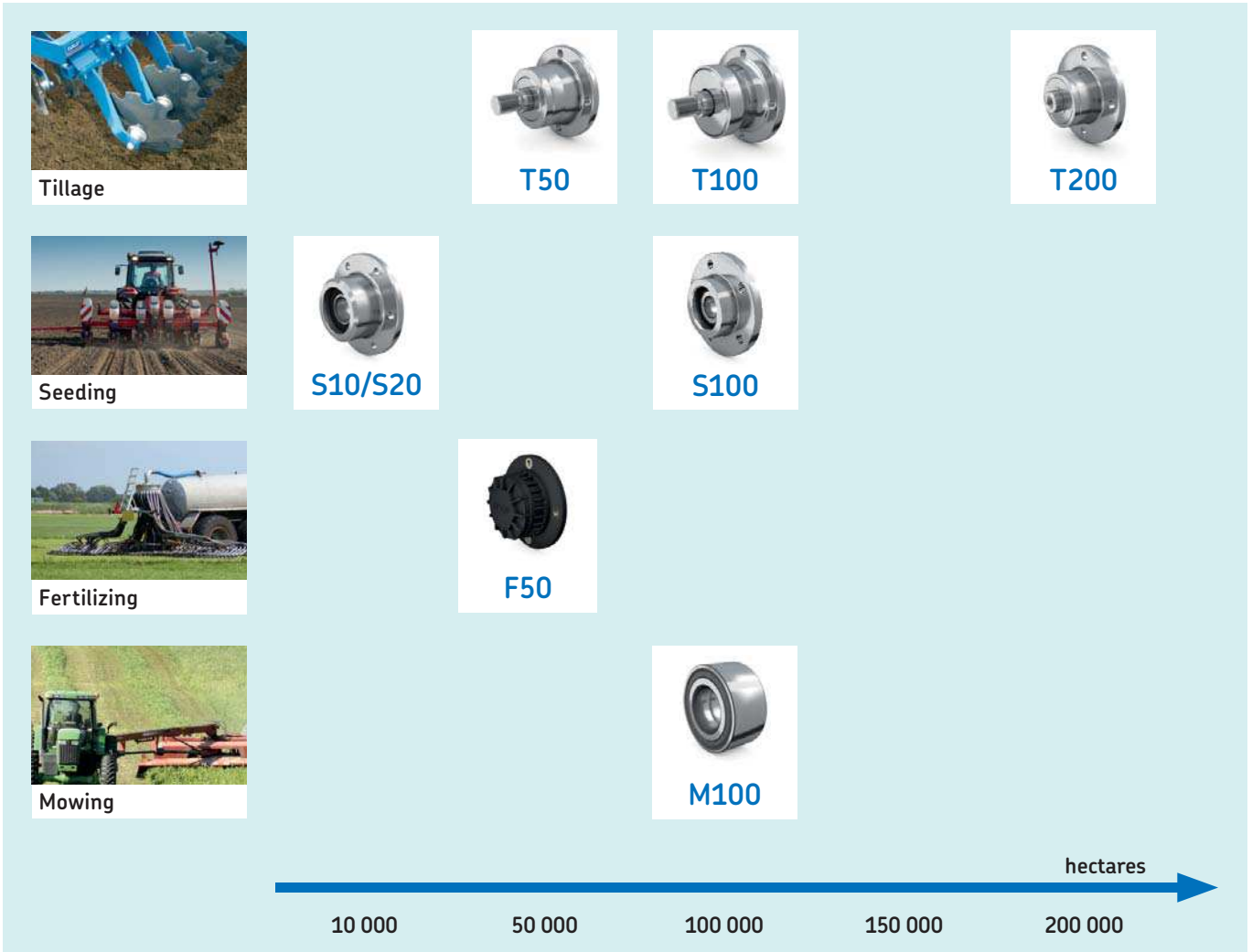

Range overview



* All figures and graphs are rounded off and based on SKF testing estimates. Particular savings and results may vary

Mud slurry testing

Our Research and Development Center utilizes mud slurry testing to thoroughly study new seal concepts before extensive field tests are conducted to validate application performance. The test is performed to determine the effectiveness of the bearing sealing device to withstand contamination intrusion under aggressive environmental conditions. Seal designs are tested against competitive parts in side-by-side mud slurry testing. Seal performance is one of the most crucial factors influencing bearing life and field performance in agricultural applications. We offers solutions which fit environmental and machine requirements.





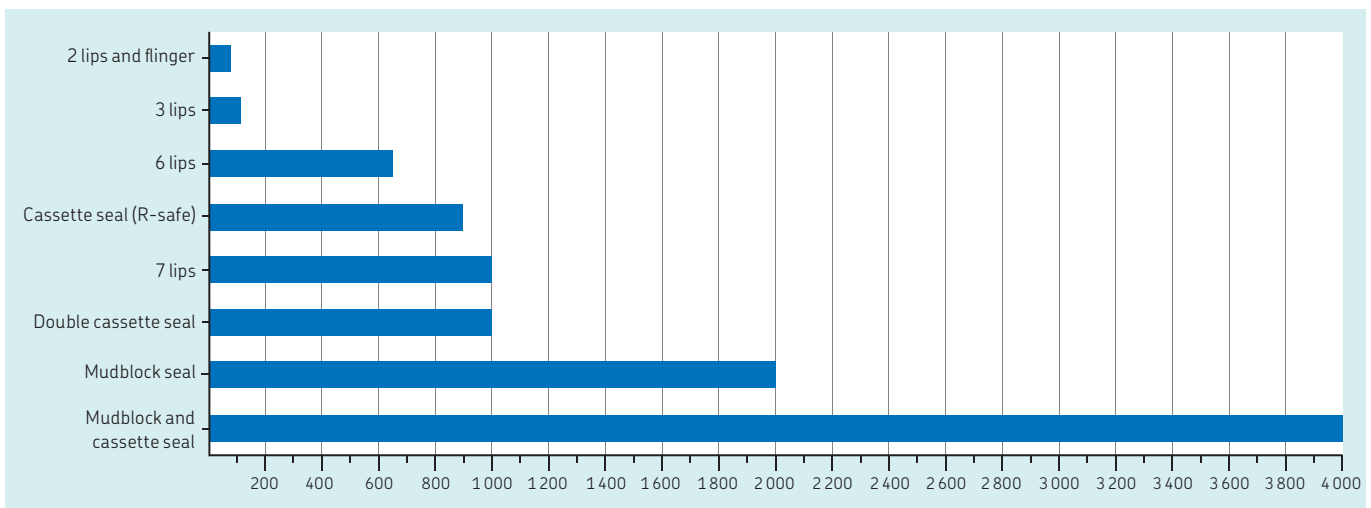

The various seal designs show a different level of performance in the contaminated environment of application.

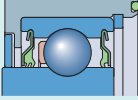
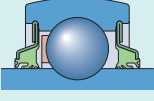

Source: Lab test and SKF and PEER customer field experience in Maintenance Free Solutions since 1997

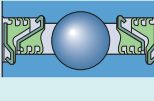
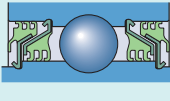
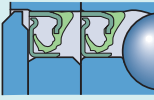
Sealing range overview

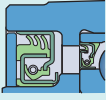
Seal	Seal Cross Section	Contamination	Machine
2 lip + flinger		Moderate	Seeding, Moving
3 lip		Severe	Seeding
Cassette seal (R-safe)		Severe	Seeding, Moving
6 lip		Severe	Seeding, Tillage
7 lip		Severe	Tillage
Double cassette seal		Severe	Tillage
Mudblock seal		Extreme	Tillage
Mudblock and cassette seal		Extreme	Tillage, Fertilizing

According to application and typical environment, recommended seal design differs. Our application engineers can guide and develop new product and seal designs together with you before mud slurry testing and field tests can validate the product.

Agri Hub T50 for tillage



Type 4

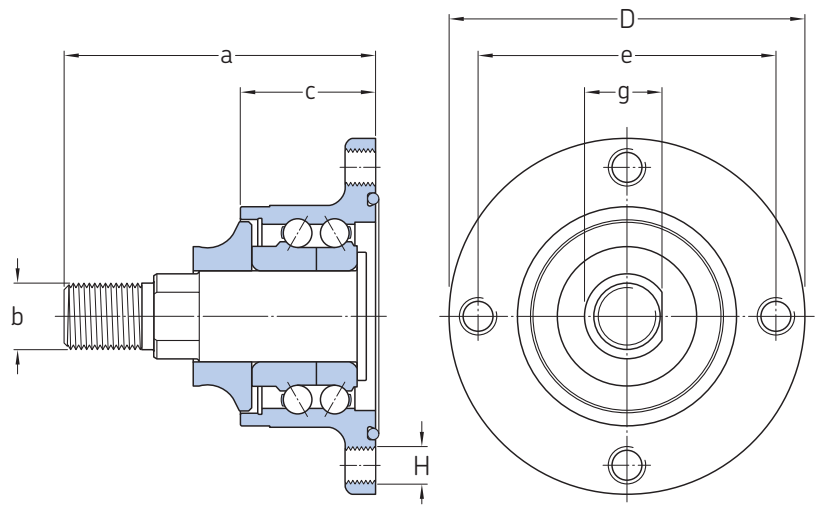

Type 2

Product designation	PEER part number	Type	b	e	c
				mm	mm
AGHU3098X4D-6L	HUB-30MM	3	M22x1.5	98	45
AGHU30101X4E - V11	HUB-30MM-ASSY-A528	2 or 3	–	101,6	56
AGHU3098X4E-7LC	HUB-30MM-X-ASSY-A577	2	M22x1.5	98	62
AGHU3098X4D-6L	HUB-30MM-ASSY-A623	3	5/8" - 18 UNF DEEP	98	45
AGHU3098X4D-7LC	HUB-30MM-X-ASSY-A164	2	M24x2	98	60
AGHU30127X4E-7LC	HUB-30MM-X-ASSY-A549	3	5/8" - 18 UNF DEEP	127	50,8
AGHU3098X4D-7LC	HUB-30MM-X-ASSY-A615	2	M22x1.5	98	60
AGHU3098X4D-7LC-V12	HUB-30MM-X-ASSY-A626	2	M20x1	98	80
AGHU30107.95X6E-3LCS	HUB-30MM-ASSY-A687	2	7/8" - 14	107,95	76,2
AGHK3098X4D-6L	KIT-HUB-30MM-ASSY-A74	3	M22x1.5	98	45
AGHK3098X4D-7LC	KIT-HUB-30MM-ASSY-A221	2	M22x1.5	98	60
AGHU2898X4E-DSC	*	4	M22x1.5	98	60
AGHU2898X4E-DSCS	*	4	M22x1.5	98	60
AGHU2898X5E-DSCS	*	4	M22x1.5	98	60
AGHU2898X6E-DSCS	*	4	M22x1.5	98	60
AGHU2890X5E-DSC	*	4	M22x1.5	90	60

* Order designation is the same as the product designation

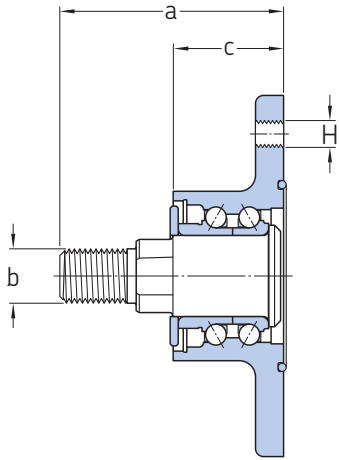

Type 3

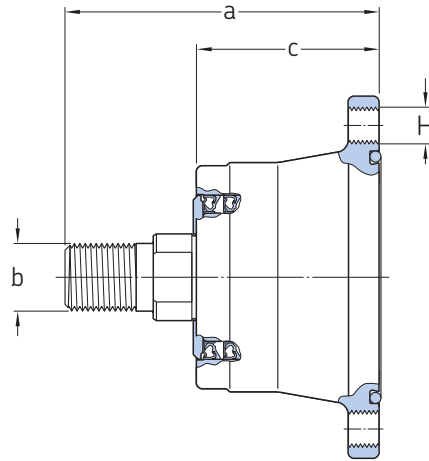

Type 4

a	D	g	Thread/hole	Seal type	Disc diameter
mm	mm	mm	H		Depending on application
			–	–	mm
88	117	25,5	4x M12x1.25	6 lips	up to 610
–	127	–	4x 10 SQUARE	7 lips	up to 610
104	120	25,5	4x Ø14	7 lips	up to 610
58,5	117	25,5	4x M12x1.25	6 lips	up to 610
104	117	25,5	4x M12x1.25	7 lips	up to 610
64,3	168	25,5	4x 1/2"-20 UNF	7 lips	up to 610
112	117	25,5	4x M12x1.75	7 lips	up to 610
120	117	23	4x M12x1.25	7 lips	up to 610
126,38	127	24,62	6 x Ø10.72	3 lips	up to 610
88	117	25,5	4x M12x1.25	6 lips	up to 610
104	117	25,5	4x M12x1.25	7 lips	up to 610
102	117	25,5	–	Double cassette seal	up to 610
102	117	25,5	–	Double cassette seal	up to 610
102	117	25,5	–	Double cassette seal	up to 610
102	117	25,5	–	Double cassette seal	up to 610
102	117	25,5	–	Double cassette seal	up to 610

Agri Hub T50 for tillage



Type 4

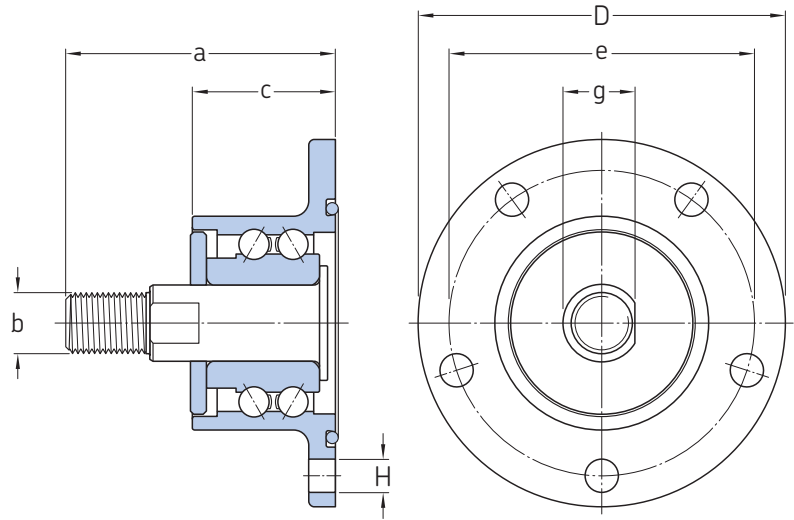

Type 1

Product designation	PEER part number	Type			
			b	e	c
				mm	mm
AGHU35112X5D-6L	HUB-35MM	3	M24x2	112	52,5
AGHU35112X5E-6L	HUB-35MM-ASSY-A519	1	M24x2	112	53,5
AGHU35150X6D-7LC	HUB-35MM-X-ASSY-A243	3	M24x2	150	61
AGHU35150X6D-7LC-V12	HUB-35MM-X-ASSY-A601	3	M24x2	150	61
AGHK35112X5D-6L	KIT-HUB-35MM-ASSY-A74	3	M24x2	112	52,5
AGHK35150X6D-7LC	KIT-HUB-35MM-ASSY-A243	3	M24x2	150	61
AGHU40140X5D-6L	HUB-40MM-ASSY	3	M27x2	140	55
AGHU40180X6E-6LC	HUB-40MM-ASSY-A554	1	M30x2	180	70
AGHU40140X5D-7LC	HUB-40MM-X-ASSY-A436	3	M27x2	140	55
AGHU40122X6D-7LC	HUB-40MM-X-ASSY-A438	3	M20x1.5 DEEP	122	55
AGHU40135.35X4D-7LC	HUB-40MM-X-ASSY-A439	3	3/4" -16 UNF DEEP	133,35	67
AGHU40102X4D-7LC	HUB-40MM-X-ASSY-A548	3	M35x1.5	102	59
AGHU40133.40X4D-7LC	HUB-40MM-X-ASSY-A575	3	M20x1.5 DEEP	133,4	55
AGHU40140X5D-7LC-V13	HUB-40MM-X-ASSY-A591	3	M27x2	140	55
AGHU40113X5D-7LC	HUB-40MM-X-ASSY-A614	3	M27x2	113	55
AGHU40130X6D-7LC	HUB-40MM-X-ASSY-A628	3	M27x2	130	55
AGHU401024DT-7LC	HUB-40MM-X-TRB-T11	2	M35x1.5	102	82
AGHK40140X5D-6L	KIT-HUB-40MM-ASSY-A74	3	M27x2	140	55
AGHU40113.03X5E-CS	PAGH-001-ASSY2	4	1/4" - 7 UNC	113,03	93,98

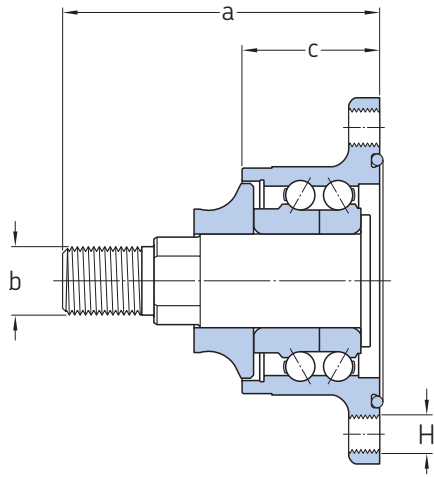

Type 2

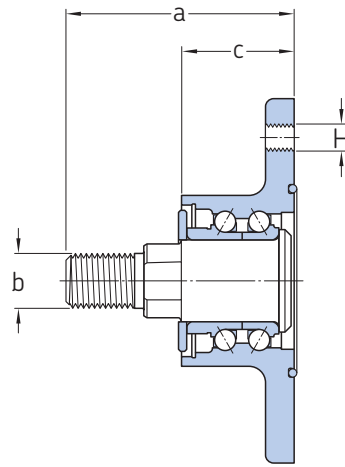

Type 3

a	D	g	Thread/hole	Seal type	Disc diameter
mm	mm	mm	H		Depending on application mm
98,5	140	28	5x M12x1.5	6 lips	up to 650
98,5	140	28	5x M12x1.5	6 lips	up to 650
116	178	28	6x M12x1.25	7 lips	up to 650
119	178	28	6x M12x1.25	7 lips	up to 650
98,5	140	28	5x M12x1.5	6 lips	up to 650
116	178	28	6x M12x1.25	7 lips	up to 650
111	178	33,5	5x Ø12.5	6 lips	700-750
144,5	212	-	6x Ø15	6 lips	700-750
111	178	33,5	5x M12x1.25	7 lips	700-750
70	152	31	6x M12x1.75	7 lips	700-750
82	168	31	4x Ø13.5	7 lips	700-750
77,5	125	35	4x Ø13.5	7 lips	700-750
70	158	31	4x M14x1.5	7 lips	700-750
111	178	33,5	5x Ø12.5	7 lips	700-750
111	178	33,5	5x M12x1.25	7 lips	700-750
111	178	33,5	6x M12x1.25	7 lips	700-750
100,5	125	35	4x Ø13.5	7 lips	700-750
111	178	33,5	5x Ø12.5	7 lips	700-750
-	139,4	-	5 x 1/2 - 13 UNC	CAP	700-750

Agri Hub T100 for tillage



Type 2

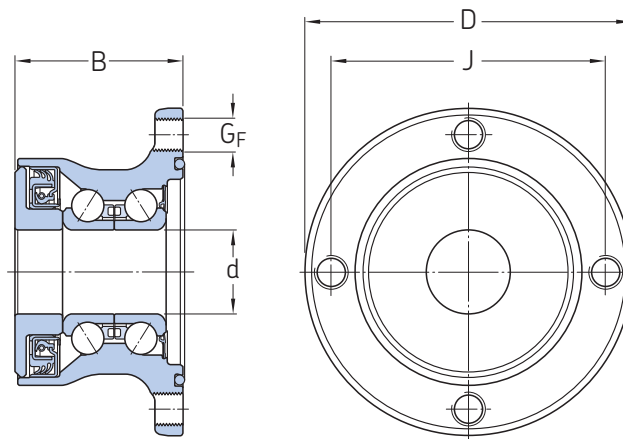

Type 1

Product designation	Order part number	Type	Key dimensions		Shaft thread
			D	d	
–	–	–	mm	mm	G ₅
AGHU3098X4D-MBC	BAA-0003	1	117	30	No shaft
AGHU3098X4D-MBC-V10	BAA-0003 A ¹⁾	1	117	30	No shaft
AGHU3098X4C-MBC	BAA-0004	2	117	30	M22x1,5
AGHU3098X4C-MBC-V03	BAA-0005	2	117	30	M24x1,5
AGHU3098X6C-MBC	BAA-0006	2	117	30	M22x1,5
AGHU3098X5C-MBC	BAA-0012	2	117	30	M22x1,5
AGHU3098X6C-MBC-V03	BAA-0013	2	117	30	M24x1,5
AGHU3098X4D-MBC-V02	BAA-0023	2	117	30	M22x1,5

¹⁾ without labyrinth ring

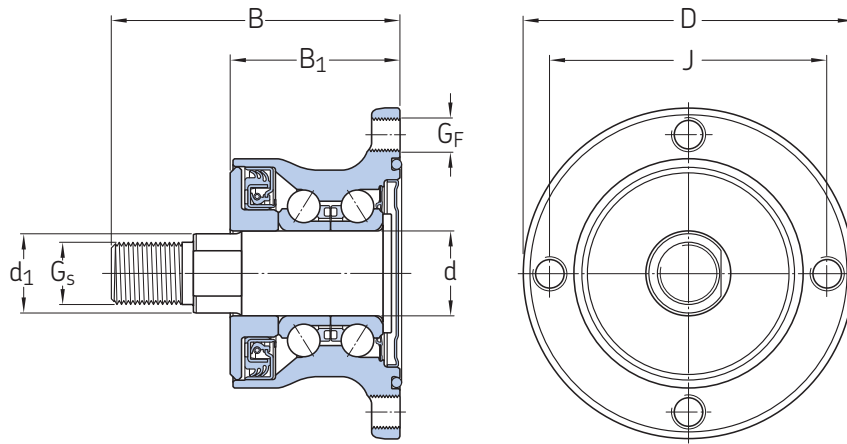

Type 2

		Flange mounting	PCD	Flange bolts	Thread	Seal type	Disc diameter
d_1	B_1	B	J		G_F		mm
mm	mm	mm	mm	–	mm	–	mm
–	–	60	98	4	M12x1,25	Mudblock seal	up to 610
–	–	60	98	4	M12x1,25	Mudblock seal	up to 610
28	60	102	98	4	M12x1,25	Mudblock seal	up to 610
28	60	102	98	4	M12x1,25	Mudblock seal	up to 610
28	60	102	98	6	M12x1,25	Mudblock seal	up to 610
28	60	102	98	5	M12x1,25	Mudblock seal	up to 610
28	60	102	98	6	M12x1,25	Mudblock seal	up to 610
28	60	102	98	4	M12x1,25	Mudblock seal	up to 610

Agri Hub T200 for tillage



Type 1

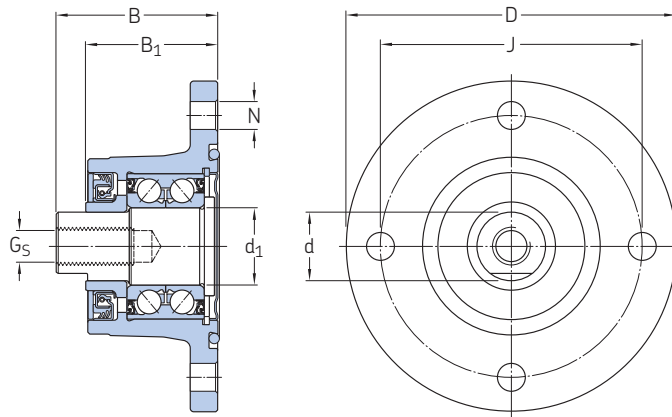

Type 1

Product designation	Order part number	Type	Key dimensions		Shaft thread
			D	d	
–	–	–	mm	mm	–
AGHU39X133X4C-MCC-V04	BAA-0026	1	168	39	female - 3/4-16 UNF
AGHU39133X4C-MCC-V04	BAA-0037	1	168	39	female – M20 metric

*Mudblock seal and cassette R safe seal

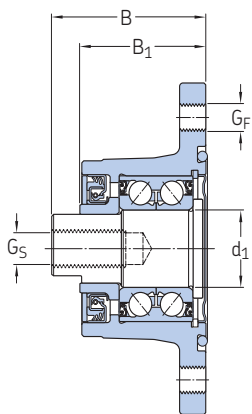

Type 1

		Flange mounting	PCD	Flange bolts	Thread	Seal type	Disc diameter
d_1	B_1	B	J		N/ G_f		
mm	mm	mm	mm	–	mm	–	mm
34,9	67	82	133,35	4	Diameter 13,5	*	700-750
34,9	67	82	133,35	4	M14x1,5 – metric	*	700-750

Agri Hub S10 and S20 for seeding



Type 2 (S20)

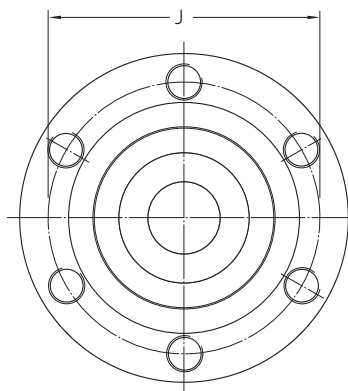
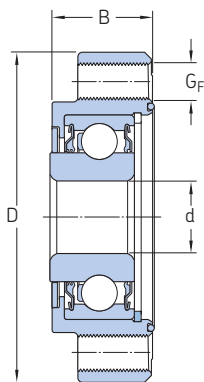

Type 1

Product designation	Order part number	Type	Key dimensions			
			d	B	D ₁	D
–	–	–	mm	mm	mm	mm
AGHU1660X6E-2L-V01	AGHU1660X6E-2L-V01	1	20	22,7	–	–
AGHU2098X6F-1L5L	ADH-7558	2	20	–	54	91
AGHU2098X6H-1L5L	ADH-7545	3	20	29,5	55	91
AGHU1698X6H-1L5L	ADH-7545 B	3	16	31,5	55	91
AGHU2098X6H-5L1L	ADH-7546	3	20	29,5	55	91
AGHU1698X6H-5L1L	ADH-7546 B	3	16	31,5	55	91

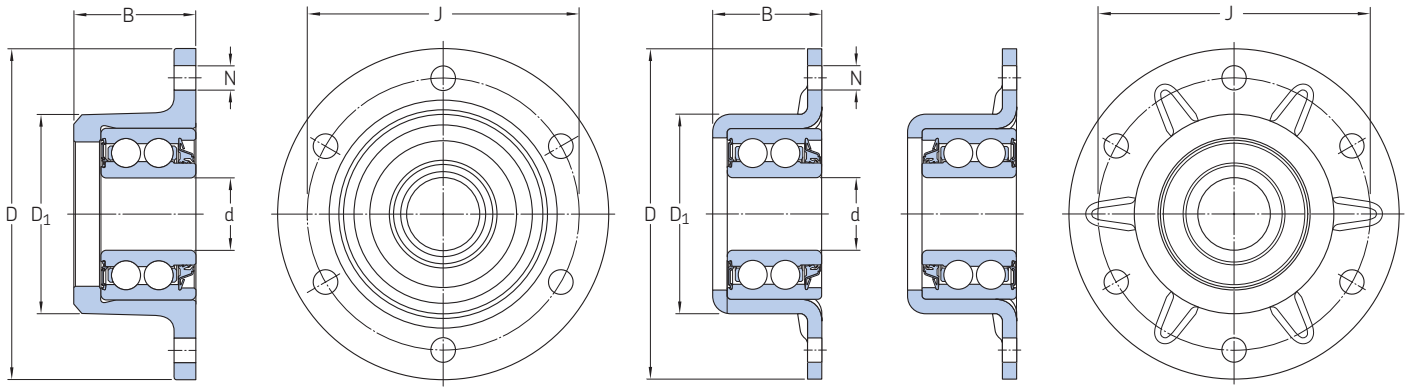

Type 2

Type 3

Flange mounting	Flange bolts	Thread	Seal type	Disc diameter
PCD				
J		N/G _F		
mm	–	mm	–	mm
60	6	M8X1,25	2 lip and flinger	up to 350
75	6	Ø6,7 +0,15/-0	3 lip	up to 350
75	6	Ø6,7 +0,25/-0	3 lip	up to 350
75	6	Ø6,7 +0,25/-0	3 lip	up to 350
75	6	Ø6,7 +0,25/-0	3 lip	up to 350
75	6	Ø6,7 +0,25/-0	3 lip	up to 350

Agri Hub S100 for seeding



Type 1

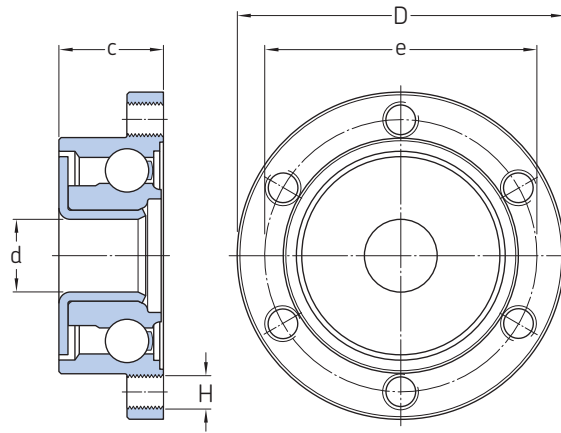

Type 1

Product designation	PEER part number	Type			
			b	e	c
			mm		
–	–	–	–	mm	mm
AGHU1660X6D-6L	HUB-16MM-X	1	–	60	23
AGHU1678X6D-6L	HUB-16MM-X-R-A391	3	–	78	37
AGHU1660X6D-6L-V14	KIT-HUB-16MM-X-R-A70	1	–	60	23
–	HUB-18MM-R-A72	1	–	60	23
–	HUB-16MM-X-R-A391	1	–	78	37
AGHU2080X5D-6LC	HUB-20MM-X	2 or 1	M16x2	80	38
AGHU2080X5E-6LC	HUB-20MM-X-ASSY-A543	2 or 1	M16x2	80	41,2
AGHU2080X5D-6LC-V15	HUB-20MM-X-ASSY-A546	1	M16x2	80	38
AGHU2080X5D-6L	HUB-20MM-X-ASSY-A553	1 or 2	M16x2	80	38
AGHU2080X5E-6L	HUB-20MM-X-ASSY-A580	1 or 2	M16x2	80	38
AGHU2075X6E-6L	HUB-20MM-X-ASSY-A605	2 or 1	M16x2	75	38
AGHU2080X5E-6L-V16	HUB-20MM-X-ASSY-A613	2 or 1	M16x2	80	38
AGHK2080X5D-6LC	KIT-HUB-20MM-X-ASSY-A157	1	M16x2	80	38
AGHK20114.30X4E-6LC	HUB-20MM-ASSY-A671	3	5/8"-18 UNF	127	55,6
–	BB204-PF3-R-FC-A459	1	–	80	–
–	BB204-KPP58-R-FC-A480	1	–	79,4	–
–	BB204-KPP58-R-FC-A481	1	–	79,4	–
–	BB204-KPMF59-R-FC-A481	1	–	79,4	–
–	BB204-PF3-R-DFC-A555	1	–	60	–
–	BB204-PY3-R-ZDFC-A481	1	–	60	–

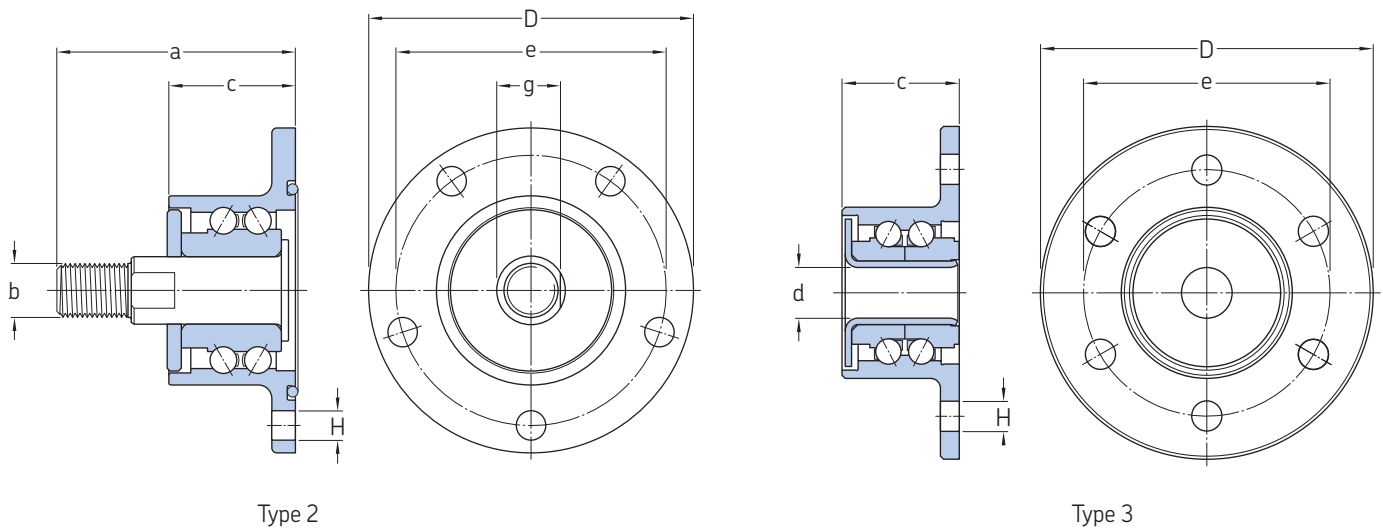

Type 2

Type 3

					Thread/hole	Seal type	Disc diameter
a	D	g	d	H			
mm	mm	mm	mm	–	–	–	mm
–	72	–	16	6x M8x1	6 lips	up to 350mm	
–	105	–	16,053	6x Ø9.6	6 lips	up to 350mm	
–	72	–	16	6x M8x1.0	6 lips	up to 350mm	
–	78	–	18	6x M8x1.0	MULTILIPS + OIL Seal+ single lip	–	
–	105	–	16,065	6x M8x1.0	6 lips	–	
73	100	18,5	–	5x Ø8.5 H12	6 lips	up to 350mm	
75,2	100	18,5	–	6x M8x1.25	6 lips	up to 350mm	
73	100	18,5	–	6x Ø8.5 H12	6 lips	up to 350mm	
73	100	18,5	–	5x Ø8.5 H12	6 lips	up to 350mm	
71	100	18,5	–	5x Ø8.5 H12	6 lips	up to 350mm	
68	100	18,5	–	6x M6x1	6 lips	up to 350mm	
73	100	18,5	–	5x M16x1	6 lips	up to 350mm	
73	100	18,5	–	5x Ø8.5 H12	6 lips	up to 350mm	
91,35	152,4	17,5	–	4x Ø14.30/6 x Ø10.4	6 lips	up to 350mm	
16,67	95	–	16,053	5x Ø6.5	3 lips	up to 350mm	
31,2	100	–	20	6x Ø8.2	3 lips	up to 350mm	
31,2	100	–	20	5x M8x1	3 lips	up to 350mm	
32,7	100	–	20	5x M8x1	6 lips	up to 350mm	
31,67	75	–	16,053	5x M8x1.25	3 lips	up to 350mm	
28	75	–	16,053	4x M6x1	1 lips	up to 350mm	

Agri Hub F50 for fertilizing

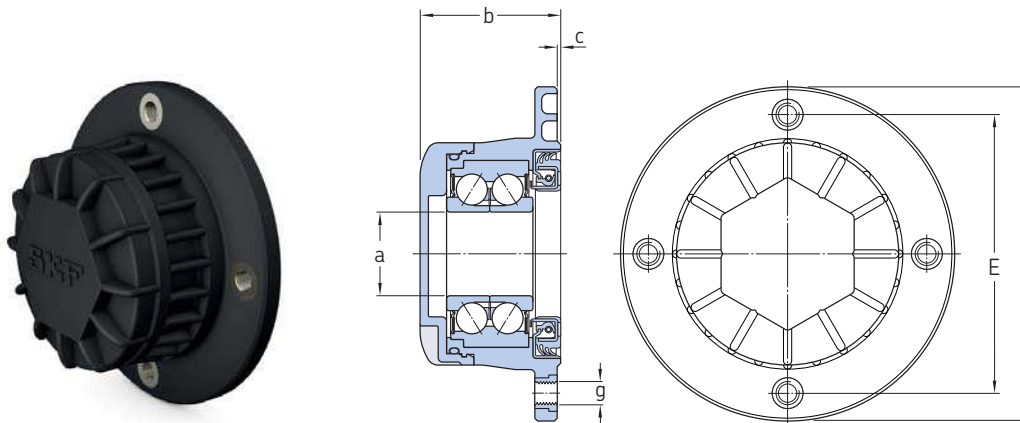

Product designation	Order part number							Attachment holes	Max. tilting moment	Shaft
		a	b	c	E	F	g	Nm		
–	–	mm	mm	mm	mm	mm	–		–	
AGHU30100X4M-CMB	BAA-0025	30	41	1,3	100	120	4 × M8 × 1,25	45	Not included	

Agri Hub M100 for mowing

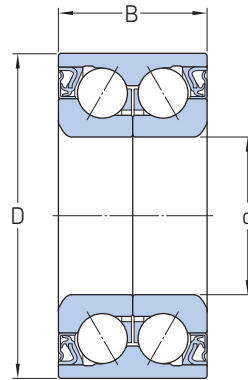

Product designation	Order part number	d	D	B
		mm	mm	mm
AGHU3572B-CSCS	BAH-0013 E ¹⁾	35	72	33
AGHU3572B-LSLS	BAH-0013 D ²⁾	35	72	33
AGHU3572B-CSOS	BAH-0013 AB ³⁾	35	72	33

¹⁾ Low friction seal ²⁾ Cassette seal ³⁾ Oil seal

Agri Hub designation system

Agri Hub designation system

1.1	1.2	2.1	2.2	2.3	X	2.4	3.	4.1	4.2	5.
AG	Hx	nnn	(X)	nnn		x	x(T)	nx	nx	

1. Serie prefix

- 1.1 Agriculture products initiate by prefix AG
- 1.2 Agriculture product types
 HU, Agri Hub
 HK, Kit with Agri Hub, screw and washers, nut

2. Hub dimensions

- 2.1 Bore
 Metric in mm uncoded in 2 or 3 digits
 Inch in fractions of 1/16 of an inch in 3 digits.
 i.e. 1 digit, No. of inches. 2 and 3 digit 1/16 of inches.
- 2.2 Units systems
 Exclude (X) for metric sizes
 Include (X) for inch sizes
- 2.3 Pitch diameter for disc holes or bearing OD
 Unit with flange:, pitch diameter for disc holes dimension, (in mm uncoded if metric 2 or 3 digits but larger than 2.1, 3 digits if inch as per 2.1)
 Bearing only:, bearing OD in mm
- 2.4 ID for No. of disc holes or bearing only.
 Digit for the No. of disc holes
 Exclude digit refer to bearing only

- ### 3. Type of Hub and shaft features and or bearing type
- x(T), first x define Hub type features and if T define taper rolling bearings.

4. Sealings

- 4.1 Seal type on the dynamic side
 1 digit and 1 letter or 2 letters
 Flinger or shield or labyrinth are standard.
- 4.2 Seal or cover on the flange side
 1 digit and 1 letter or 2 letters
 Without cover are standard for design with shaft on one dynamic side.

5. Non standard features

- V followed by 2 digits, locally registered by the products line owner.

Agri Hub designation system

3. Type of Hub and shaft features and or bearing type

- B = bearing only, no shaft no housing - (ex. mower HBU1 BAH 0013)
- C = Integrated Unit, Zinc with Shaft
- D = Integrated Unit, Zinc without Shaft
- E = Modular Unit, Steel Flange housing Zinc with shaft
- F = Modular Unit, Steel Flange housing Zinc without shaft
- G = Modular Unit, Pressed Steel Flange housing Zinc with shaft
- H = Modular Unit, Pressed Steel Flange housing Zinc without shaft
- J = Modular Unit, Cast Iron Flange housing Zinc with shaft
- K = Modular Unit, Cast Iron Flange housing Zinc without shaft
- L = Modular Unit, Composite Flange housing with shaft
- M = Modular Unit, Composite Flange housing without shaft
- T = Define Tapered roller bearing

4.1 Seal type on the dynamic side

- 1L = 1 Lip (radial)
- 2L = 2 Lips (radial)
- 3L = 3 Lips (radial)
- 4L = 4 Lips (radial)
- 5L = 5 Lips(radial)
- LC = 5 Lips - 3 contacting
- 6L = 6 Lips (radial)
- DL = Double lip - radial/axial seal
- CS = Cassette R-Safe
- DS = Double Cassette R-Safe
- MB = Mud Block
- MC = Mud Block and R Safe
- MS = Mechanical Face Seal
- LF = Low friction seal
- OS = Oil seal

4.2 Seal or cover on the flange side

- Seal type same as 4.1
- C = Cover

5. Non standard features

- V01= Fe/Zn 7 Cr 120-360 iridescent/S zinc coating (special coating for seeding)
- V02 = zinc on the end shaft*
- V03 = Special thread (ex. M24)*
- V04 = Special female thread*
- V05 = Shaft Zinc Coated*
- V06 = Special Shaft Length*
- V07 = Special flinger coating*
- V08 = Flinger Labyrinth or shield*
- V09 = housing painted*
- V10 = without labyrinth ring

* To be further discussed/detailed once needed

Designation examples

Modular units

Metric
AGHU1660X6E-2L-V01

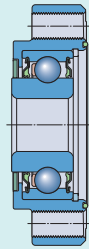

AGHU Agri Hub
 16 Bore 16 mm
 60 Flanged pitch diameter 60 mm
 X6 6 Holes
 E Type, Modular unit, Steel flange housing zinc with shaft
 2L Seal, 2 lips (radial)
 V01 Zinc coating Fe/Zn 7 Cr120-360 iridescent/S
 (special coating for seeding)

Integrated units

Metric
AGHU3098X4D-MB

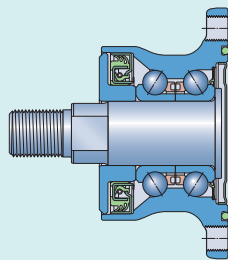

AGHU Agri Hub
 30 Bore 30 mm
 98 Flanged pitch diameter 98 mm
 X4 4 Holes
 D Type, Integrated unit, Zinc without shaft
 MB Mudblock seal

Bearings

Metric
AGHU5090B-2L



AGHU Agri Hub
 50 Bore 50 mm
 90 Outer diameter 90 mm
 B Bearing only
 2L Seal, 2 lips (radial)

Inch

AGHU103X315X4D-MB

Inch dimension of the relevant design
 103 X 315 same as for metric, but X defines inch in fraction
 of 1/16 i.e. 1.3/16X3.15/16.

Kit in common

AGHK1660X6E-2L-V01, same as the first example in the
 table, but product include all screw, washer and nut.