

GEARBOXES

POWER AT WORK.



Worm
Gearbox
Catalogue
2015



4 Sati

Since 1974

www.satispa.com



Sati è una realtà importante nella produzione e distribuzione di prodotti per la trasmissione di potenza ad uso industriale. Fondata nel 1974, Sati è diventata leader nel settore coniugando l'esperienza all'innovazione. Quello che rende unica Sati sono il servizio e la capacità di risposta al cliente.

L'ampia gamma di prodotti, la velocità e la puntualità nella consegna sono i nostri punti di forza. Un magazzino organizzato con le più moderne tecnologie gestionali, personale altamente qualificato e multilingue e un sistema di consegna in tempo reale sono i motivi che spingono sempre più clienti a scegliere Sati.

Sati è fuori standard non solo per il servizio d'eccellenza offerto, ma anche per la sua produzione di articoli speciali a disegno. Il nostro personale qualificato esegue accurati studi di fattibilità, seleziona i migliori produttori sul mercato italiano o asiatico ed esegue rigorosi controlli qualitativi sui componenti ricevuti. Procedure collaudate per prodotti sempre diversi: per Sati anche lo speciale è ordinaria amministrazione! La vasta gamma di articoli a catalogo rispetta normative e misure internazionali; i processi interni sono tutti rispondenti all'UNI EN ISO 9001.

In un mondo che corre Sati riesce a essere competitiva e rendere competitivi i propri clienti, perché noi il prodotto lo consegniamo subito, con puntualità, in qualsiasi quantità e in qualsiasi parte del mondo. Il magazzino di SATI, con i suoi 5000 metri quadri di superficie, è il centro strategico dell'azienda. Il nostro sistema informatizzato è uno strumento fondamentale per gestire più di 10.000 articoli in giacenza e 20.000 spedizioni annuali. Inoltre grazie a Diogene, un sistema di E-Business avanzato, il rapporto con la nostra clientela è sempre più stretto. Inviare ordini, verificare se la spedizione è già stata eseguita, ristampare le fatture: con Diogene il cliente può controllare in tempo reale lo stato dei suoi acquisti.

Tutto ciò che vi serve, ovunque. Con rapidità e puntualità.



Sati is a major player in the production and distribution of power transmission products for industrial use. Founded in 1974, Sati has grown up to the rank of leading company in its sector combining experience with innovation. What makes Sati unique are the excellence in service and the uncompromising dedication to customer's needs.

Our strength is represented by a wide range of products as well as fast and timely deliveries. In addition to this, a warehouse equipped with the most advanced management technologies, highly qualified multilingual staff and real-time delivery of orders are further reasons why more and more customers decide to give their preference to Sati.

Sati is out-of-standard not only for the excellence of its service, but also for the engineering of special design items. Our highly qualified team, through deeply detailed feasibility study, scouts and selects the top manufacturers on the Italian or on the Asian markets and performs strict quality controls on all components. Well tested procedures for the largest product diversification: for Sati, extraordinary is ordinary! Our vast range of off-the-shelf articles respects all the international standards and regulations; internal processes all comply with UNI EN ISO 9001.

In a world that runs so fast, Sati succeeds in being competitive, and in making its customers competitive, too, because we deliver products immediately, timely, in whatever amount and everywhere in the world. Sati's warehouse, with its 5000 square metres, is the strategical centre of the company. Our computerized system is a key tool to handle over 10.000 articles in stock and 20.000 shipments per year. Besides, Diogene, a leading-edge E-Business tool, allows us to come closer to our customers, who can enter orders, verify their shipments' progress, reprint their invoices: Diogene enables our customers to have real-time control on the status of their purchases.

All you need, everywhere. Fast and timely.

Мотор-редуктор SATI VP (NMRV) / WORM GEARBOXES

Presentazione della gamma SATI di riduttori a vite senza fine / <i>SATI worm gearboxes range</i>	2
Designazione / <i>Designation</i>	4
Posizioni di montaggio e quantità olio / <i>Mounting positions and quantity of oil</i>	8
Esecuzione / <i>Versions</i>	9
Lubrificazione / <i>Lubrication</i>	9
Controllo del livello e cambi dell'olio / <i>Level check and oil change</i>	10
Simbologia / <i>Symbols</i>	10
Introduzione / <i>Introduction</i>	10
Velocità entrata / <i>Input speed</i>	10
Rapporto di riduzione / <i>Reduction ratio</i>	10
Velocità in uscita / <i>Output speed</i>	11
Coppia massima in uscita / <i>Max output torque</i>	11
Coppia trasmessa / <i>Output torque</i>	11
Coppia richiesta / <i>Required torque</i>	11
Potenza massima in entrata / <i>Max input power</i>	11
Potenza massima in uscita / <i>Max output power</i>	11
Potenza nominale in entrata / <i>Rated input power</i>	12
Rendimento / <i>Efficiency</i>	12
Irreversibilità / <i>Irreversibility</i>	12
Irreversibilità dinamica / <i>Dynamic irreversibility</i>	12
Irreversibilità statica / <i>Static irreversibility</i>	12
Fattore di servizio / <i>Service factor</i>	13
Carichi radiali / <i>Radial loads</i>	14
Carichi radiali uscita / <i>Output radial loads</i>	14
Carichi radiali entrata / <i>Input radial loads</i>	15
Carichi assiali / <i>Axial loads</i>	15
Senso di rotazione / <i>Direction of rotation</i>	15
Selezione / <i>Selection</i>	16
Scelta del riduttore / <i>Selecting of gearbox</i>	16
Scelta del motoriduttore / <i>Selecting of gearmotor</i>	17
Temperatura operativa / <i>Operating temperature</i>	17
Verniciatura / <i>Painting</i>	17
Installazione / <i>Installation</i>	18
Identificazione / <i>Identification</i>	18
Predisposizioni IEC / <i>IEC Pre-arrangements</i>	19
Dati tecnici / <i>Technical data</i>	22
Tabella dati tecnici motoriduttori / <i>Table technical data gearmotors</i>	36
Dimensioni riduttori a vite senza fine / <i>Dimensions worm gearboxes</i>	60
Dimensioni riduttori a vite senza fine con precoppia / <i>Dimensions helical worm gearboxes</i>	70
Dimensioni a vite senza fine combinati / <i>Dimensions combination worm gearboxes</i>	82
Seconda entrata / <i>Additional input</i>	92
Kit assemblaggio - Accessori / <i>Assembly Kit - Accessories</i>	92
Disegno esploso / <i>Exploded view</i>	97
Motori elettrici / <i>Electric motors</i>	99
Condizioni generali di vendita / <i>General sales terms</i>	108

Типы исполнения червячных мотор-редукторов SATI VP (NMRV) / SATI worm gearbox range



SATI ha il piacere di presentare la sua nuova gamma di riduttori a vite senza fine, che entra a far parte, della vasta gamma di prodotti per la trasmissione del moto.

I riduttori a vite senza fine SATI sono disponibili nelle seguenti versioni:

- riduttori a vite senza fine semplici, costituiti da un singolo stadio di riduzione tramite coppia vite senza fine/corona elicoidale, con **rapporti di riduzione compresi fra 7,5/1 e 100/1**.

La gamma di riduttori a vite senza fine semplici consta di **10 grandezze che vanno dalla 25 fino alla 150**.

- riduttori a vite senza fine con **precoppia**, ovvero provvisti di un ulteriore stadio di riduzione ad ingranaggi elicoidali, un prestadio, situato a monte del riduttore.

Le grandezze dello stadio di precoppia sono 4 (**63-71-80 e 90**), che possono essere accoppiate a più grandezze di riduttori, come riportato nelle tabelle che seguono.

I rapporti di riduzione dei riduttori con precoppia vanno da **73,5/1 fino a 400/1**.

- riduttori **combinati** a vite senza fine, costituiti da due riduttori accoppiati in cascata fra di loro, ovvero disposti in serie l'uno dopo l'altro, in modo tale che il rapporto di riduzione totale del combinato sia pari al prodotto dei rapporti dei due stadi singoli accoppiati.

I rapporti di riduzione dei combinati vanno **da 100/1 fino a 5000/1**.

A complemento dei riduttori SATI propone ai suoi clienti anche i **motori elettrici asincroni trifase**, a singola velocità, nelle versioni a 2, 4 e 6 poli, in forma flangiata B5 o B14 dalla grandezza IEC 56 fino alla grandezza IEC 160, per accoppiamento diretto ai riduttori o, in alternativa, in forma con piedi B3.

Tutti i riduttori singoli e combinati sono disponibili tanto con entrata PAM, ovvero predisposta per accoppiamento diretto del motore elettrico, quanto con entrata albero maschio sporgente per accoppiamento ad una trasmissione in entrata.

La designazione dei prodotti, come apparirà chiaramente anche nelle tabelle che seguono, è la seguente:

- **VP** riduttore singolo con predisposizione **PAM**
- **VI** riduttore singolo con **entrata albero maschio**
- **VC** riduttore **combinato** con predisposizione **PAM**
- **VS** riduttore **combinato** con **entrata albero maschio**
- **VR** riduttori a vite senza fine con **precoppia** fornito nella sola versione con predisposizione **PAM**

La ragione per la quale i riduttori con precoppia sono forniti esclusivamente in versione PAM è che lo stadio di precoppia funge a tutti gli effetti pratici da stadio di riduzione in entrata, alla stessa stregua delle trasmissioni meccaniche, per cui l'eventuale impiego di una trasmissione in entrata risulta superfluo.

SATI is pleased to introduce its new range of worm gearboxes, which joins its wide range of power transmission products.

SATI worm gearboxes are available in the following versions:

- single worm gearboxes, consisting of a single reduction stage through a worm/helical wormwheel pair, with **reduction ratios between 7.5/1 and 100/1**.

The range of single worm gearboxes consists of **10 sizes, ranging from 25 to 150**.

- helical worm gearboxes, which have an additional reduction stage with helical gears, a pre-stage, located upstream of the gearbox.

The pre-stage consists of 4 sizes (**63-71-80 and 90**), which can be fitted with a certain number of gearbox sizes, as stated in the following tables.

The reduction ratios of the helical worm gearboxes range from **73.5/1 to 400/1**.

- **combination** worm gearboxes, consisting of two gearboxes fitted in cascade one after the other, that is to say arranged in series one after the other, in such a way that the total reduction ratio of the combination unit is equal to the product of the individual ratios of the two mutually connected single stages.

The reduction ratios of the combination gearboxes range **from 100/1 to 5000/1**.

In addition to its gearboxes, SATI offers its customers a range of **three-phase asynchronous single-speed electric motors**, in versions with 2, 4 and 6 poles, in B5 or B14 flanged version, size IEC 56 up to size IEC 160, for direct connection to the gearboxes or, alternatively, the foot-mounting B3 version.

All single and combination gearboxes are available both with PAM input, in other words ready for direct connection to the electric motor, and with the extended solid input shaft for connection to an input transmission.

Product designation, as is also clearly shown in the tables below, is as follows:

- **VP** single gearbox, with **PAM pre-arrangement**
- **VI** single gearbox with **solid input shaft**
- **VC** combination gearbox, with **PAM pre-arrangement**
- **VS** combination gearbox with **solid input shaft**
- **VR** helical worm gearboxes supplied only in the **PAM** version

The reason why the helical worm gearboxes are supplied only in the PAM version is that the pre-stage acts, to all practical effects, as an input reduction stage, in the same way as a mechanical transmission, so that the usage of an input transmission is meaningless.

SATI VP - гамма мотор-редукторов VP (NMRV) / SATI worm gearbox range

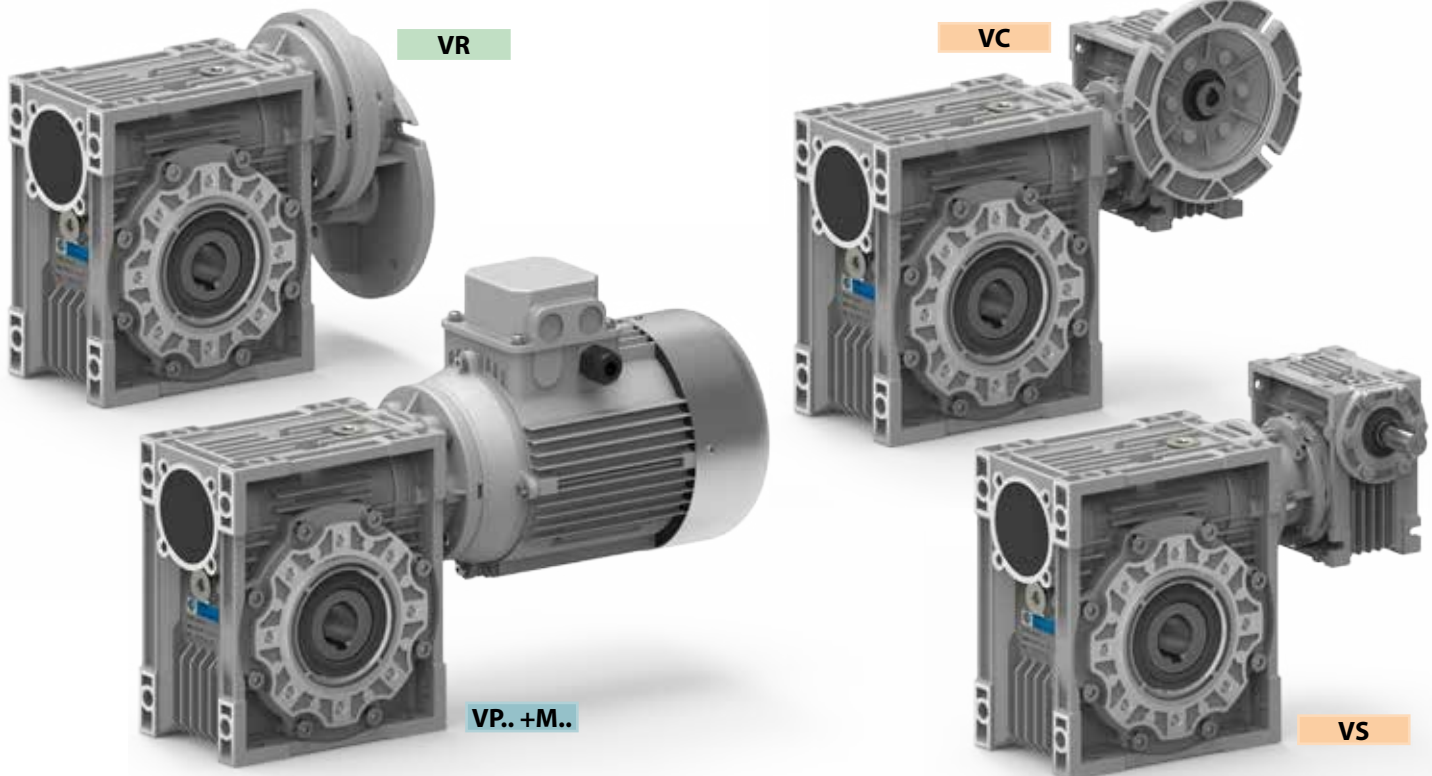

Gli **alberi uscita standard**, chiamati anche alberi lenti o a bassa velocità, sono cavi.
Come accessori, sono fornibili alberi uscita maschi semplici e doppi, oltreché il **braccio di reazione** per montaggio pendolare.

Le carcasse dei riduttori della gamma a vite senza fine hanno forma quadrata, consentendo una notevole flessibilità di installazione.
I piedi sono incorporati alla carcassa ed i riduttori sono idonei per montaggio su pavimento, soffitto e pareti laterali.
La versatilità e flessibilità del montaggio è uno dei reali punti di forza di questa gamma.
Come opzioni, SATI offre anche una vasta gamma di **flange in uscita**, che possono essere montate sul lato destro o sinistro dell'uscita riduttore.
Nelle pagine di catalogo dedicate ad ogni singola grandezza, è possibile prendere visione del numero e delle dimensioni delle flange uscita disponibili.

I due stadi dei riduttori combinati sono accoppiati fra di loro mediante flangia di combinazione ed albero di combinazione, il che rende particolarmente agevole e flessibile l'accoppiamento.

MATERIALI E PROPRIETA'

La carcassa dei riduttori dalla grandezza 25 fino alla grandezza 90 è costruita in **alluminio** da pressofusione.
La carcassa dei riduttori dalla grandezza 110 alla grandezza 150 è costruita in **ghisa** grigia.
Tutte le viti senza fine sono in acciaio legato da cementazione ad alta resistenza e sono cementate, temprate e sottoposte a rinvenimento di distensione.
Le corone elicoidali sono in **bronzo** ad alta resistenza all'usura.
Gli alberi lenti cavi sono in ghisa grigia.

PUNTI DI FORZA DELLA GAMMA SATI

I riduttori a vite senza fine sono i tipi di riduttore più versatili e flessibili e si prestano ad una vastissima gamma di possibili applicazioni.
I riduttori della gamma SATI hanno il grande vantaggio di essere facili da installare e disinstallare, nei quali le esigenze di manutenzione sono veramente ridotte al minimo.
Efficienti e robusti, si adattano ad ogni condizione di impiego che rientri nelle relative specifiche di funzionamento.

*The **standard output shafts**, also called low speed shafts, are hollow. Single and double solid output shafts can be supplied as accessories, as well as the **torque arm** for shaft-mounting.*

*The housings of the worm gearboxes have a square shape, permitting high installation flexibility.
The feet are incorporated into the housing and the gearboxes are ideal for mounting on the floor, ceiling and side walls.
Assembly versatility and flexibility is one of the actual strong points of this range.
As options, SATI can also offer a **wide range of output flanges**, which can be fitted on the right or left side of the gearbox output.
You can look at the number and size of the available output flanges for each size on the pages in the catalogue devoted to each size.*

The combination gearboxes are mutually fitted by means of a combination flange and a combination shaft, which makes fitting particularly easy and flexible.

MATERIALS AND PROPERTIES

*The housing of the gearboxes from size 25 up to size 90 is made of pressure die casting aluminium.
The housing of the gearboxes from size 110 up to size 150 is made of **grey cast iron**.
All worms are made of high strength, case-hardening alloy steel and are case-hardened, hardened and subjected to stress relieving.
The helical wormwheels are made of high wear resistant **bronze**.
The hollow output shafts are made of grey cast iron.*

STRONG POINTS OF THE SATI RANGE

*The worm gearboxes are the most versatile and flexible types of gearboxes and prove to be ideal for a wide range of possible applications.
The gearboxes in the SATI range have the great advantage of being easy to install and uninstall, where maintenance needs are really minimal.
Strong and efficient, they adapt to all conditions of use within their operating specifications.*

Designazione / Designation

RIDUTTORE A VITE SENZA FINE QUADRO FLANGIATO / WORM GEARBOXES WITH FLANGE ACCESSORI / ACCESSORIES

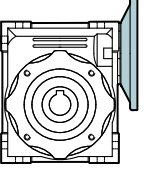
Riduttore Gearbox	Grandezza Size	Versione riduttore Gearbox Version	Posizione flangia uscita Position Output flange	Rapporto rid. = i Ratio = i	Predispos. attacco motore Motor coupling	Forma costruttiva Version	Posizione di mont. Mounting position	Seconda entrata Additional input	Albero uscita Output shaft	Braccio di reazione Torque arm
VP	040	P	-	R10	63	B5	U	-	AD	BR
	025 030 040 050 063 075 090 110 130 150	P FA FB FC FD FE p.60	- DX SX	R7.5 R10 R15 R20 R25 R30 R40 R50 R60 R80 R100	56 63 71 80 90 100 112 132	B5 B14	U* B3 B6 B7 B8 V5 V6 p.8	- B p.93	AS AD p.93	BR p.93

RIDUTTORE A VITE SENZA FINE QUADRO / WORM GEARBOXES ACCESSORI / ACCESSORIES

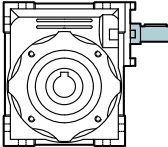
Riduttore Gearbox	Grandezza Size	Versione riduttore Gearbox Version	Posizione flangia uscita Position Output flange	Rapporto rid. = i Ratio = i	Posizione di mont. Mounting position	Seconda entrata Additional input	Albero uscita Output shaft	Braccio di reazione Torque arm
VI	040	P	-	R10	U	-	AD	BR
	030 040 050 063 075 090 110 130 150	P FA FB FC FD FE p.60	- DX SX	R7.5 R10 R15 R20 R25 R30 R40 R50 R60 R80 R100	U* B3 B6 B7 B8 V5 V6 p.8	- B p.93	AS AD p.93	BR p.93

Versione riduttore / Gearbox version

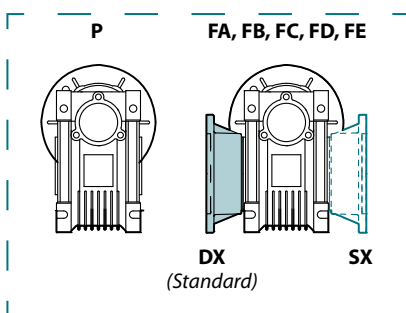

Seconda entrata / Additional input

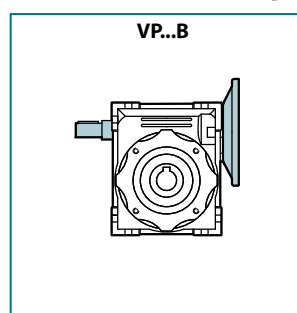



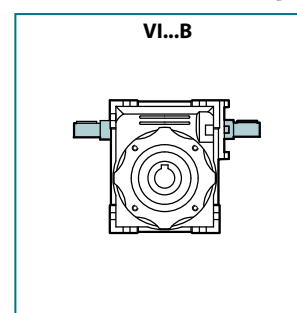



Seconda entrata / Additional input

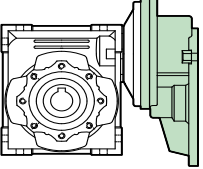

* Dalla gr. 25 alla 63, i riduttori sono forniti in posizione U = Universale

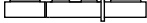
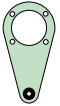
* From size 25 to 63, the gearboxes are supplied in position U = Universal

Designazione / Designation

RIDUTTORE A VITE SENZA FINE CON PRECOPPIA / HELICAL WORM GEARBOXES							ACCESSORI / ACCESSORIES			
Riduttore Gearbox	Grandezza precoppia Size pre-stage	Grandezza riduttore Size gearbox	Versione riduttore Gearbox Version	Posizione flangia uscita Position Output flange	Rapporto rid. = i Ratio = i	Predispos. attacco motore Motor coupling	Forma costruttiva Version	Posizione di montaggio Mounting position	Albero uscita Output shaft	Braccio di reazione Torque arm
VR	063/040	P	-	R73.5	63 B5	U	AD	BR		
	063/040 063/050 071/050 071/063 071/075 080/075 080/090 080/110 090/090 090/110 090/130	P FA FB FC FD FE	- DX SX	R61.2 R73.5 R75 R88.2 R90 R98 R117.5 R120 R122.5 R147 R150 R176.4 R180 R235.2 R240 R294 R300 (1)	63 71 80 90	B5	U* B3 B6 B7 B8 V5 V6	AS  AD 	BR 	
										

Versione riduttore / Gearbox version

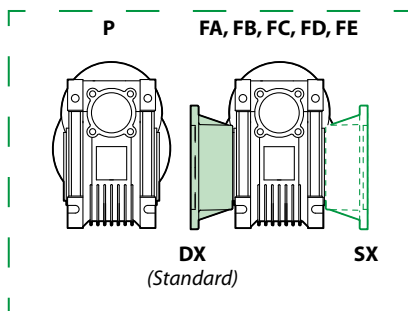

(1) Rapporti di riduzione reali del kit precoppia, consultare tab. p.20

* Dalla gr. 25 alla 63, i riduttori sono forniti in posizione U = Universale

(1) Actual reduction ratios, see table p.20

* From size 25 to 63, the gearboxes are supplied in position U = Universal

Designazione / Designation

RIDUTTORE COMBINATI A VITE SENZA FINE / COMBINATION WORM GEARBOXES								ACCESSORI / ACCESSORIES			
Riduttore Gearbox	Grandezza riduttore entrata Size input gearbox	Grandezza riduttore uscita Size output gearbox	Versione riduttore Gearbox Version	Posizione flangia uscita Position Output flange	Rapporto rid. = i Ratio = i	Predispos. attacco motore Motor coupling	Forma costruttiva Version	Esecuzione Version	Posizione di montaggio Mounting position	Albero uscita Output shaft	Braccio di reazione Torque arm
VC	030/040	P	-	R5000	63	B5	ADO	U	AD	BR	
	025/030 025/040 030/040 030/050 030/063 040/075 040/090 050/110 063/130 063/150	P FA FB FC FD FE	- DX SX	R100 R150 R200 R250 R300 R400 R500 R600 R750 R900 R1200 R1500 R1800 R2400 R3000 R4000 R4800 R5000	56 63 71 80 90 100 112 132	B5 B14	ADO BDO ADV BDV ASO BSO ASV BSV	U* B3 B6 B7 B8 V5 V6 (1)	AS AD	BR	

RIDUTTORE COMBINATI A VITE SENZA FINE / COMBINATION WORM GEARBOXES								ACCESSORI / ACCESSORIES	
Riduttore Gearbox	Grandezza riduttore entrata Size input gearbox	Grandezza riduttore uscita Size output gearbox	Versione riduttore Gearbox Version	Posizione flangia uscita Position Output flange	Rapporto rid. = i Ratio = i	Esecuzione Version	Posizione di montaggio Mounting position	Albero uscita Output shaft	Braccio di reazione Torque arm
VS	030/040	P	-	R5000		ADO	U	AD	BR
	030/040 030/050 030/063 040/075 040/090 050/110 063/130 063/150	P FA FB FC FD FE	- DX SX	R100 R150 R200 R250 R300 R400 R500 R600 R750 R900 R1200 R1500 R1800 R2400 R3000 R4000 R4800 R5000		ADO BDO ADV BDV ASO BSO ASV BSV	U* B3 B6 B7 B8 V5 V6 (1)	AS AD	BR

Versione riduttore / Gearbox version

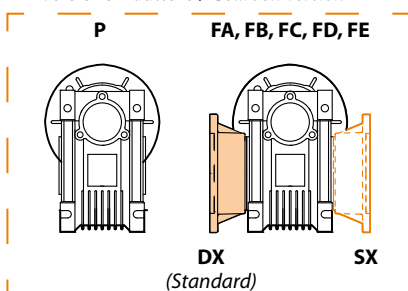

(1) Posizione di montaggio riferita al riduttore uscita



* Dalla gr. 25 alla 63, i riduttori sono forniti in posizione U = Universale

(1) Mounting position refers to output gearbox

* From size 25 to 63, the gearboxes are supplied in position U = Universal

Designazione / Designation

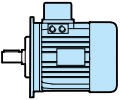
MOTORE / MOTOR

Motore Motor	Classe energetica * Energy class *	Grandezza Size	Potenza kW Power kW	Numero di poli Number of poles	Forma costruttiva Version
M	1	63	0.25	4P	B5
 	1 2 3	56 63 71 80 90 100 112 132 160	0.06 0.09 0.12 0.18 0.25 0.37 0.55 0.75 1.1 1.5 2.2 3 4 5.5 7.5 11 15	2P 4P 6P	B3 B5 B14

*
I motori rispettano la normativa IEC 60034-30:2008 in riferimento alle "Classi di rendimento dei motori asincroni trifase a gabbia ad una velocità (codice IE)".

Tale norma prevede l'introduzione delle seguenti classi energetiche:

- IE1 fino a 0.55 kW (codice 1 in designazione SATI)
- IE2 da 0.75 kW a 5.5 kW (codice 2 in designazione SATI)
- IE3 da 7.5 kW a 15 kW (codice 3 in designazione SATI)

sono esclusi i motori autofrenanti, i motori realizzati in ambiente esplosivi e quelli realizzati per servizio intermittente (S3).

*
Motors comply with IEC 60034-30:2008 regulation, with reference to "Efficiency classes of single speed, asynchronous three-phase cage motors (IE code)".

This standard introduces the following energy classes:

- IE1 up to 0.55 kW (code 1 in SATI designation)
- IE2 from 0.75 kW to 5.5 kW (code 2 in SATI designation)
- IE3 over 7.5 kW (code 3 in SATI designation)

This excludes brake motors, explosion-proof motors and motors conceived for intermittent duty cycle (S3).

VP 040 ... + M 1 63 ...

La designazione dei motoriduttori si ottiene sommando il codice riduttore al codice motore.

Per maggiori informazioni contattare il nostro ufficio tecnico.

The designation of gearmotors is obtained by summing the gear code with the motor code.

For further information please contact our Technical Office.

Posizioni di montaggio e quantità olio / Mounting positions and quantity of oil

VP / VI

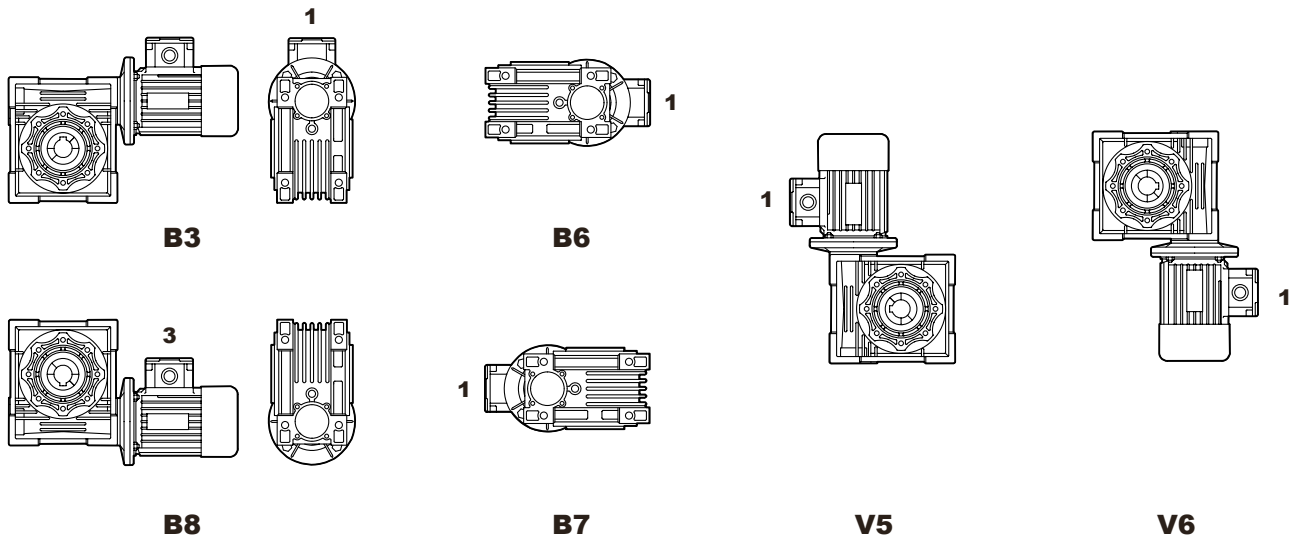

VP / VI	025	030	040	050	063	075	090	110	130	150
B3	0.02	0.04	0.08	0.15	0.3	0.55	1	3	4.5	7
B8								2.2	3.3	5.1
B6 - B7								2.5	3.5	5.4
V5								3	4.5	7
V6								2.2	3.3	5.1

Q.tà olio in litri
Oil quantity in liters

VR

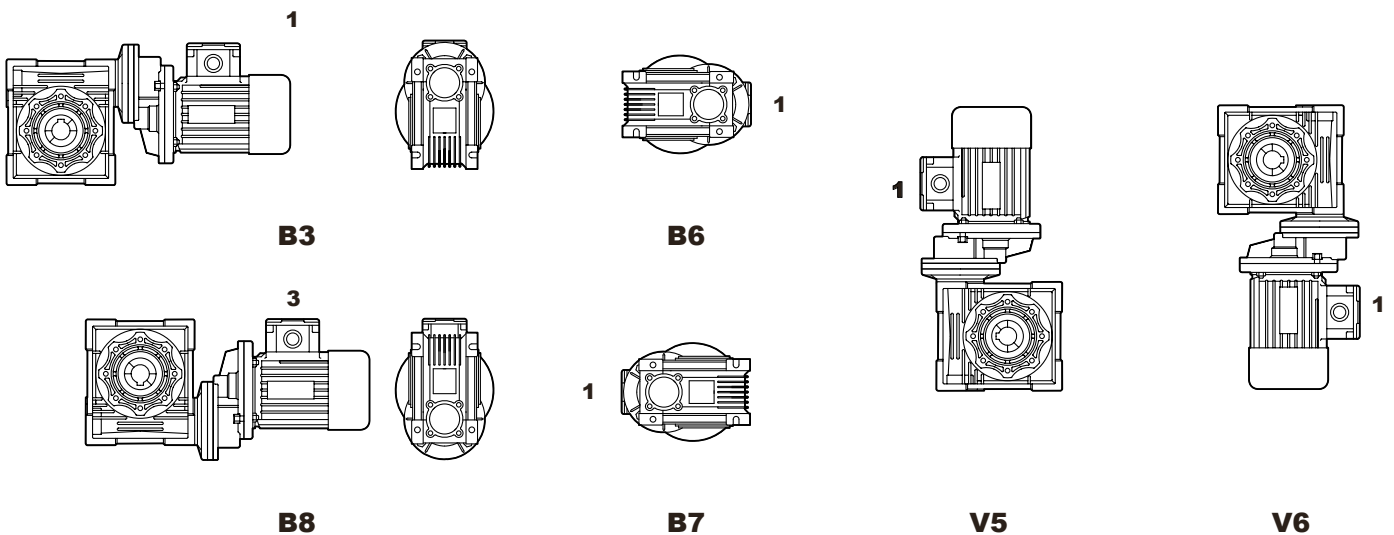

VR	063	071	080	090
	0.05	0.07	0.15	0.15

Q.tà olio in litri
Oil quantity in litres

Esecuzione / Versions

VC / VS

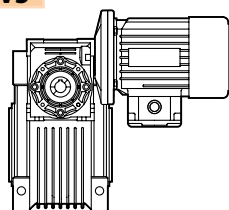

ADO

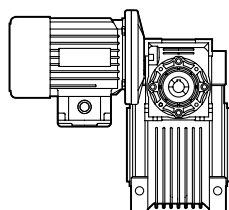

ASO

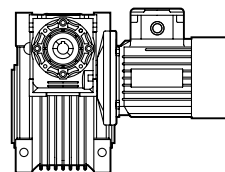

BDO

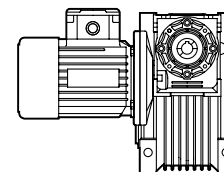

BSO

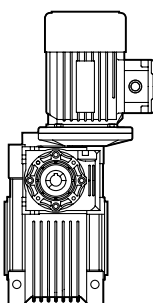

ADV

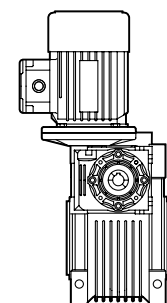

ASV

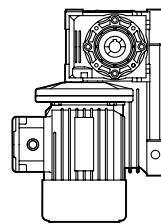

BSV

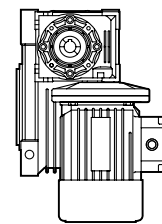

BDV

Nel caso dei riduttori combinati sono importanti tanto l'esecuzione quanto la posizione di montaggio.
L'esecuzione rappresenta la posizione reciproca che i due riduttori hanno uno rispetto all'altro.
Nelle immagini che definiscono le varie forme di esecuzione, il riduttore è sempre rappresentato in posizione di montaggio B3.
Per quel che riguarda invece la posizione di montaggio, essa fa esplicito riferimento al secondo riduttore, quello situato a valle.
Le varie posizioni di montaggio (indicate con le sigle B3, V5 ecc..) si riferiscono a detto riduttore e sono conformi a quanto indicato nelle tabelle delle posizioni di montaggio dei riduttori singoli.

In the specific case of combined worm gearboxes, both the version and the mounting position have a great importance.
The version means the mutual position the two single worm gearboxes have in relation one with the other.
In the sketches that define the several possible versions, the combined unit is always shown in the mounting position B3.
On the other hand, as far as the mounting position is concerned, this one makes explicit reference to the second worm gearbox, the one located downstream.
The various mounting positions (indicated by the descriptions B3, V5 etc..) refer to said unit and wholly conform to what is stated in the tables of the mounting positions of the single worm gearboxes.

Рекомендованные масла для червячных редукторов VP (NMRV) / Lubrification

Tutti i riduttori SATI serie VP, VI, VR, VC e VS sono forniti completi di lubrificante.
Dalla grandezza 25 fino alla 90 i riduttori sono lubrificati con olio sintetico e non necessitano di manutenzione; per questa ragione sono definiti riduttori "lifetime".
Queste grandezze non richiedendo manutenzione e sono prive di tappi.
Dalla grandezza 110 alla 150 i riduttori sono lubrificati con olio minerale e vengono forniti completi di lubrificante nella quantità prevista in posizione di montaggio B3. In caso di posizione di montaggio diversa dalla B3, sarà compito del cliente adattare la quantità di olio alla posizione di montaggio (v. tab. precedenti). E' inoltre necessario al momento della messa in opera del riduttore, sostituire il tappo di carico, fornito chiuso per motivi di trasporto, con quello di sfiato fornito a corredo del riduttore stesso. La mancata installazione del tappo di sfiato può portare ad un malfunzionamento del riduttore e a possibili perdite di lubrificante.
Sarà inoltre cura del cliente installare i tappi di livello e di scarico nella corretta collocazione per la specifica posizione di montaggio adottata.
Per le grandezze dalla 110 alla 150, successivamente alla fase di rodaggio (circa 300 ore di funzionamento) si consiglia la sostituzione dell'olio.
Nelle tabelle precedenti sono riportate le quantità indicative di lubrificante contenute nei singoli riduttori in funzione delle posizioni di montaggio.
Nelle sostituzioni o nei rabbocchi, ricordarsi sempre di verificare che il lubrificante abbia raggiunto il livello corretto guardando nella spia trasparente del tappo di livello (il corretto livello è in mezzzeria).

All SATI VP, VI, VR, VC and VS series gearboxes are supplied complete with lubricant.
From size 25 to 90, the gearboxes are lubricated with synthetic oil and do not require any maintenance; for this reason, they are called lifetime gearboxes. These maintenance-free sizes have no plugs.
From size 110 to 150, the gearboxes are lubricated with mineral oil and are supplied with the required oil amount for the mounting position B3. For mounting positions other than B3, it will be the responsibility of the customer to adjust the oil amount to the needs of the specific mounting position (see previous tab.). It is also necessary, at the time of installation of the gearbox, to replace the filler plug, supplied closed for reasons of transport, with the breather plug supplied with the gearbox itself. Failure to install the breather plug can lead to gearbox malfunctioning and possibly oil leakage.

It will also be necessary to remember to install the level and unloading plugs in the correct place for the specific mounting position.
For sizes from 110 to 150, after the running-in phase (approximately 300 hours of operation) we recommend changing the oil.
The above tables give the approximate amounts of lubricant contained in the single gearboxes according to the mounting positions.
When changing the oil or topping up, always remember to check that the lubricant reaches the correct level by looking through the window in the level plug (the correct level is in the centre).

VP / VI	025 - 030 - 040 - 050 - 063 - 075 - 090	110 - 130 - 150
Lubrificante / Lubricant	Olio sintetico / Synthetic oil	Olio minerale / Mineral oil
°C Ambiente / Ambient	-25 ° / +50 °C	-5 ° / +40 °C
ISO	VG 320	VG 220
SHELL	TIVELA OIL S 320	OMALA OIL 220
MOBIL	SHC 632	MOBILGEAR 630
BP	ENERGOL SGXP320	ENERGOL GRXP 220
CASTROL	ALPHA SYNT PG320	ALPHA MAX 220

Controllo del livello e cambi dell'olio / Level check and oil change

Sono richiesti e necessari solamente per i riduttori lubrificati con olio minerale.

In linea di massima, si consiglia di provvedere al cambio dell'olio con la seguente frequenza;

- Temperatura operativa minore o uguale a 60 °C:
servizio continuo: 5000 ore
servizio intermittente: 8000 ore
- Temperatura operativa maggiore di 60 °C:
servizio continuo: 2500 ore
servizio intermittente: 5000 ore

Gli attuali riduttori non richiedono più come requisito indispensabile il cambio dell'olio dopo un periodo iniziale di rodaggio.

These actions are needed only for gearboxes lubricated with mineral oil.

Generally, it is advisable to change the oil with the following frequency:

- *Operating temperature below 60°C*
continuous service: 5000 hours
intermittent service: 8000 hours
- *Operating temperature above 60°C*
continuous service: 2500 hours
intermittent service: 5000 hours

The current gearboxes no longer require an oil change as a prerequisite after an initial run-in period.

Simbologia / Symbols

n_1	[min ⁻¹]	Velocità in ingresso / <i>Input speed</i>
n_2	[min ⁻¹]	Velocità in uscita / <i>Output speed</i>
i		Rapporto di riduzione / <i>Ratio</i>
Mm_2	[Nm]	Coppia massima in uscita / <i>Max output torque</i>
M_2	[Nm]	Coppia trasmessa / <i>Output torque</i>
Mr_2	[Nm]	Coppia richiesta / <i>Required torque</i>
Pm_1	[kW]	Potenza massima in entrata / <i>Max input power</i>
Pm_2	[kW]	Potenza massima in uscita / <i>Max output power</i>
Pn_1	[kW]	Potenza nominale in entrata / <i>Nominal input power</i>
Rd		Rendimento dinamico / <i>Dynamic efficiency</i>
Rs		Rendimento statico / <i>Static efficiency</i>
fs		Fattore di servizio / <i>Service factor</i>
Fr_1	[N]	Carico radiale ammissibile in entrata / <i>Permitted input radial load</i>
Fa_1	[N]	Carico assiale ammissibile in entrata / <i>Permitted input axial load</i>
Fr_2	[N]	Carico radiale ammissibile in uscita / <i>Permitted output radial load</i>
Fa_2	[N]	Carico assiale ammissibile in uscita / <i>Permitted output axial load</i>

Introduzione / Introduction

La corretta selezione dei riduttori a vite senza fine avviene seguendo la successione degli argomenti esposti in questo catalogo. Di seguito vengono indicati i principali aspetti correlati delle relative indicazioni.

To select the worm gearboxes correctly, please follow the sequence of topics covered in this catalogue. Here are the main aspects along with the relevant information.

n_1 (min⁻¹)

Velocità entrata / Input speed

Indica la velocità in entrata al riduttore vite senza fine.

Dipende dal tipo di motorizzazione prescelta.

Le velocità in ingresso si riferiscono all'impiego nei paesi in cui la frequenza della corrente alternata è 50 Hz.

Per valori di velocità diversi da quelli riportati in questo documento, contattare servizio tecnico Sati.

This indicates the worm gearbox input speed.

It depends on the type of motor drive selected.

The input speeds relate to use in countries where the alternate current frequency is 50 Hz.

For speed values other than those stated in this document, please contact the Sati technical service.

i

Rapporto di riduzione / Reduction ratio

In generale, esso dipende dal numero di denti degli ingranaggi accoppiati. Nel caso di riduttori a vite senza fine, però, il rapporto di riduzione si ottiene dividendo il numero di denti della corona elicoidale per il numero di filetti, o principi, della vite.

Viene definito dalla seguente relazione:

Generally speaking, it depends on the number of teeth of the matching gears.

In the case of worm gearboxes, however, the reduction ratio is obtained by dividing the number of teeth of the helical wormwheel by the number of threads, or starts, of the worm.

It is defined by the following equation:

$$i = \frac{n_1}{n_2}$$

n_2 (min⁻¹)

Velocità in uscita / Output speed

Indica la velocità in uscita al riduttore vite senza fine.
Si ricava dalla relazione precedente:

*This indicates the worm gearbox output speed.
It is obtained from the previous equation:*

$$n_2 = \frac{n_1}{i}$$

Mm_2 (Nm)

Coppia massima in uscita / Max output torque

Indica la coppia in uscita massima trasmissibile dal riduttore considerando un funzionamento con servizio di carico continuo uniforme, corrispondente ad un fattore di servizio pari a 1, riferito ad un determinato valore di velocità n_1 .
Tale valore corrisponde al valore di coppia trasmessa dalla versione riduttore (albero sporgente in ingresso) e può essere relazionata alla coppia trasmessa M_2 tramite la seguente formula:

This indicates the maximum output torque that can be transmitted by the gearbox considering operation with a service of continuous uniform load, corresponding to a service factor of 1, relating to a specific speed value n_1 .

This value corresponds to the torque transmitted by the gearbox version (extended solid input shaft) and may be related to the transmitted torque M_2 using the following formula:

$$Mm_2 = M_2 \cdot fs$$

M_2 (Nm)

Coppia trasmessa / Output torque

Indica la coppia in uscita trasmessa dal riduttore.
Dipende dalla velocità n_1 , dalla potenza P_1 applicata in ingresso al riduttore (nel caso del motoriduttore $P_1 = Pn_1$) e dal rendimento dinamico Rd .
Può essere ricavata dalla seguente relazione:

*This indicates the output torque transmitted by the gearbox.
It depends on the speed n_1 , the power P_1 applied at the gearbox input (for gear-motor $P_1 = Pn_1$) and the dynamic efficiency Rd .
It can be obtained from the following equation:*

$$M_2 = \frac{9550 \cdot P_1 \cdot Rd}{n_2}$$

Mr_2 (Nm)

Coppia richiesta / Required torque

Indica la coppia richiesta dall'applicazione in uscita al riduttore.
E' un valore che deve essere calcolato in funzione dei dati dell'applicazione o che comunque l'utilizzatore del riduttore deve conoscere.

*This indicates the torque required by the application at the gearbox output.
It is a value to be calculated as a function of the application data or data that the gearbox user must know.*

Pm_1 (kW)

Potenza massima in entrata / Max input power

Indica la massima potenza applicabile in ingresso al riduttore considerando un funzionamento con servizio di carico continuo uniforme, corrispondente ad un fattore di servizio pari a 1, riferito ad un determinato valore di velocità n_1 .
Tale valore corrisponde al valore massimo di potenza applicabile in ingresso nella versione riduttore (albero sporgente in ingresso).

This indicates the maximum applicable gearbox input power considering operation with a service of continuous uniform load, corresponding to a service factor of 1, relating to a specific speed value n_1 .

This value corresponds to the maximum applicable input power value in the gearbox version (extended solid input shaft).

Pm_2 (kW)

Potenza massima in uscita / Max output power

Indica la massima potenza trasmessa in uscita al riduttore.
Si ricava dalle relazioni seguenti:

*This indicates the maximum transmitted gearbox output power.
It is obtained from the following equations:*

$$Pm_2 = \frac{Mm_2 \cdot n_2}{9550}$$

$$Pm_2 = Pm_1 \cdot Rd$$

P_{n_1} (kW)

Potenza nominale in entrata / Rated input power

Indica la potenza nominale del motore applicato in ingresso al riduttore.

This indicates the rated power of the motor applied to the gearbox input.

Rd / Rs

Rendimento / Efficiency

Rd: rappresenta il rendimento dinamico, definito dal rapporto tra la potenza in uscita P_2 e quella in entrata P_1 al riduttore.

Le prestazioni dei riduttori sono state determinate considerando il valore di Rd il cui valore ottimale si raggiunge nel funzionamento a regime, successivo alla fase di rodaggio.

Rs: rappresenta il rendimento statico presente in fase di avviamento.

Al fine della corretta selezione del riduttore da impiegare, nel caso di applicazioni in cui non si raggiungono mai le condizioni di funzionamento a regime (es. sollevamenti), è importante declassare le prestazioni del riduttore in uscita utilizzando Rs.

Nella tabella della pagina seguente sono riportati i valori dei rendimenti riferiti ai diversi rapporti di riduzione. Nel caso di Rd, i valori sono riferiti a $n_1 = 1400$ rpm

Rd: represents the dynamic efficiency, which is defined by the ratio of the gearbox output power P_2 to the gearbox input power P_1 .

The performance of the gearboxes has been determined considering the value of Rd, whose optimal value is reached at steady operation stage, after completion of the running-in period.

Rs: represents the static efficiency in the start-up phase.

In order to properly select the gearbox to be used, in the case of applications that never reach steady operating conditions (e.g. lifting), it is important to downgrade the performance of the output gearbox by using Rs. In practice, performance rates are downgraded by using the ratio between Rs and Rd.

The table on the next page gives the values of the efficiencies referred to different reduction ratios. In the case of Rd, the values are referred to $n_1 = 1400$ rpm

Irreversibilità / Irreversibility

Strettamente legata al valore del rendimento (dinamico e statico) è l'irreversibilità del riduttore vite senza fine che consiste nell'impossibilità di porre in rotazione l'albero entrata del riduttore tramite l'applicazione di una coppia sull'albero uscita. Il livello di difficoltà con cui l'albero entrata viene posto in rotazione determina il grado di irreversibilità di un riduttore. Questo aspetto del funzionamento dei riduttori a vite senza fine cresce con l'aumentare del rapporto di riduzione (strettamente legato al rendimento) e dipende da più fattori (es. lubrificazione, presenza di vibrazioni, temperatura, ecc) e nel caso di un'applicazione in cui è richiesto un non ritorno del carico è comunque necessario dotare l'applicazione di un altro dispositivo frenante esterno perchè il vite senza fine non garantisce da solo l'assoluta assenza di movimento.

Closely tied to the efficiency value (dynamic and static ones), there is the irreversibility of the worm gearbox, that consists in the inability of putting the gearbox input shaft in rotation by applying a torque on the output shaft. The level of difficulty by which the input shaft is put in rotation gives rise to the degree of irreversibility of a gearbox.

This aspect of the operation of worm gearboxes increases as the reduction ratio increases (closely related to the efficiency) and depends on several factors (e.g. lubrication, vibrations, temperature etc.) and in the case of an application that requires no return of the load, it is anyway necessary to equip the application with an additional outer braking device, because the worm alone does not assure the absolute absence of movement.

Irreversibilità dinamica / Dynamic irreversibility

Rappresenta la capacità di sostegno del carico in caso di arresto o assenza dell'azione motrice.

Tale condizione è di difficile ottenimento in quanto influenzata da eventuali vibrazioni che il carico può generare e dal tipo di applicazione stessa. Nella tabella sottostante sono indicati i vari gradi di irreversibilità dinamica:

This represents the ability to support the load when stopping or when there is no driving action.

This condition is difficult to obtain, since it is affected by the presence of any vibrations that the load might generate, as well as by the type of application.

The table below shows the varying degrees of dynamic irreversibility:

Rd	Irreversibilità dinamica	Dynamic irreversibility
> 0.6	Reversibilità dinamica	Dynamic reversibility
0.5 - 0.6	Reversibilità dinamica incerta	Low dynamic reversibility
0.4 - 0.5	Buona irreversibilità dinamica	Good dynamic irreversibility
< 0.4	Irreversibilità dinamica	Dynamic irreversibility

Irreversibilità statica / Static irreversibility

Rappresenta la capacità di impedimento alla rotazione indotta dall'albero uscita senza però escludere possibili rotazioni lente nel caso in cui il carico sia sottoposto o generi vibrazioni.

Nella tabella sottostante sono indicati i vari gradi di irreversibilità statica:

It refers to the ability of prevention of the rotation induced by the output shaft, without anyway excluding possible low speed rotations just in case the load is subject to or generates vibrations.

In the table below, the various degrees of static irreversibility are given:

Rs	Irreversibilità statica	Static irreversibility
> 0.55	Reversibilità statica	Static reversibility
0.5 - 0.6	Reversibilità statica incerta	Low static reversibility
< 0.4	Irreversibilità statica	Static irreversibility

$n_1 = 1400 \text{ (min}^{-1}\text{)}$		R5	R7.5	R10	R15	R20	R25	R30	R40	R50	R60	R80	R100
025	Rd	0.86	0.84	0.82	0.78	0.74		0.66	0.61	0.57	0.54		
	Rs	0.71	0.70	0.67	0.60	0.55		0.46	0.41	0.36	0.34		
030	Rd	0.86	0.84	0.81	0.76	0.72	0.67	0.64	0.58	0.54	0.50	0.44	
	Rs	0.71	0.66	0.62	0.54	0.50	0.43	0.39	0.35	0.31	0.27	0.23	
040	Rd	0.88	0.86	0.85	0.81	0.77	0.74	0.69	0.64	0.61	0.57	0.51	0.47
	Rs	0.72	0.69	0.65	0.58	0.53	0.5	0.44	0.4	0.36	0.32	0.28	0.24
050	Rd	0.87	0.86	0.84	0.8	0.77	0.74	0.7	0.65	0.61	0.57	0.51	0.49
	Rs	0.73	0.69	0.65	0.58	0.54	0.5	0.44	0.39	0.35	0.32	0.27	0.23
063	Rd		0.87	0.86	0.82	0.8	0.77	0.73	0.69	0.65	0.61	0.56	0.5
	Rs		0.7	0.65	0.59	0.54	0.5	0.45	0.4	0.36	0.33	0.28	0.24
075	Rd		0.88	0.87	0.84	0.81	0.79	0.75	0.71	0.68	0.64	0.59	0.54
	Rs		0.7	0.67	0.6	0.57	0.52	0.46	0.42	0.38	0.35	0.29	0.26
090	Rd		0.89	0.88	0.85	0.83	0.81	0.77	0.74	0.71	0.68	0.62	0.58
	Rs		0.72	0.69	0.63	0.59	0.55	0.49	0.45	0.41	0.38	0.32	0.28
110	Rd		0.89	0.88	0.85	0.84	0.83	0.78	0.77	0.74	0.71	0.66	0.62
	Rs		0.71	0.68	0.62	0.61	0.58	0.48	0.48	0.44	0.41	0.36	0.32
130	Rd		0.9	0.88	0.86	0.85	0.83	0.79	0.77	0.74	0.71	0.67	0.63
	Rs		0.71	0.68	0.62	0.6	0.57	0.49	0.46	0.43	0.39	0.34	0.3
150	Rd		0.91	0.9	0.88	0.86	0.84	0.83	0.78	0.76	0.73	0.68	0.64
	Rs		0.73	0.71	0.66	0.6	0.57	0.54	0.45	0.42	0.39	0.33	0.29

fs

Fattore di servizio / Service factor

È un valore che prende in considerazione le varie condizioni di funzionamento dell'applicazione ed indica il sovradimensionamento da applicare ad un determinato riduttore per garantire la durata richiesta e resistenza agli urti.

This value takes into account the different operating conditions of the application and indicates the oversizing to apply to a specific gearbox in order to ensure the required duration and the necessary impact strength.

I valori dei fattori di servizio sono riportati nella tabella seguente in funzione della tipologia di carico (A-B-C), dal numero di avviamenti all'ora e dalla durata del funzionamento (h/gg).

The values of the service factors are given in the following table according to the type of load (A-B-C), the number of starts per hour and the duration of operation (hours/days).

Il valore del fattore di servizio così individuato deve essere confrontato con il valore del fattore di servizio garantito dal riduttore scelto per l'applicazione (indicato nelle tabelle dati tecnici). Quest'ultimo deve essere uguale o superiore a quello individuato consultando la tabella seguente.

The service factor value, determined in this way, must be compared with the value of the service factor assured by the gearbox chosen for the application (indicated in the technical data tables). The latter must be equal to or greater than the one determined by referring to the following table.

I valori riportati in tabella si riferiscono all'azionamento con motore elettrico. Nel caso di utilizzo di motore autofrenante è necessario considerare un numero di avviamenti doppio rispetto a quello effettivamente richiesto.

The values shown in the table refer to operation with an electric motor. When using a brake motor, it is necessary to consider twice the number of starts actually required.

Classe di carico Load class	h/gg hours/day	N. AVVIAMENTI/ORA / N. START-UP/HOUR								
		2	4	8	16	32	63	125	250	500
A Carico uniforme Uniform load	4	0.8	0.8	0.9	0.9	1.0	1.1	1.1	1.2	1.2
	8	1.0	1.0	1.1	1.1	1.3	1.3	1.3	1.3	1.3
	16	1.3	1.3	1.3	1.3	1.5	1.5	1.5	1.5	1.5
	24	1.5	1.5	1.5	1.5	1.8	1.8	1.8	1.8	1.8

Classe di carico Load class	h/gg hours/day	N. AVVIAMENTI/ORA / N. START-UP/HOUR								
		2	4	8	16	32	63	125	250	500
B Carico con urti moderati Moderate shock load	4	1.0	1.0	1.0	1.0	1.3	1.3	1.3	1.3	1.3
	8	1.3	1.3	1.3	1.3	1.5	1.5	1.5	1.5	1.5
	16	1.5	1.5	1.5	1.5	1.8	1.8	1.8	1.8	1.8
	24	1.8	1.8	1.8	1.8	2.2	2.2	2.2	2.2	2.2

Classe di carico Load class	h/gg hours/day	N. AVVIAMENTI/ORA / N. START-UP/HOUR								
		2	4	8	16	32	63	125	250	500
C Carico con urti forti Heavy shock load	4	1.3	1.3	1.3	1.3	1.5	1.5	1.5	1.5	1.5
	8	1.5	1.5	1.5	1.5	1.8	1.8	1.8	1.8	1.8
	16	1.8	1.8	1.8	1.8	2.2	2.2	2.2	2.2	2.2
	24	2.2	2.2	2.2	2.2	2.5	2.5	2.5	2.5	2.5

Carichi radiali / Radial loads

L'applicazione sull'albero entrata o uscita del riduttore di un qualsiasi tipo di organo di trasmissione (es. pignone, pulegge ecc.) determina delle spinte radiali (Fr_1 su albero entrata, Fr_2 su albero uscita) che, se non considerate, possono portare al danneggiamento del riduttore stesso. Il carico radiale esterno Fr agente sull'albero del riduttore è ricavabile dalla seguente relazione:

$$Fr = \frac{2000 \cdot M \cdot w}{D}$$

in cui:

- D (mm) = diametro primitivo dell'organo di trasmissione
- w = coefficiente dipendente da tipo di trasmissione
 - w = 1.1 ruota per ingranaggio
 - w = 1.4 ruota per catena
 - w = 1.5 - 2.5 puleggia per cinghia a V

where:

- D (mm) = pitch diameter of the transmission part
- w = coefficient dependent on transmission type
 - w = 1.1 wheel for gear
 - w = 1.4 wheel for chain
 - w = 1.5 - 2.5 pulley for V belt

Il valore del carico radiale ricavato dalla relazione precedente è da confrontare con i valori di Fr_1 (se albero entrata) o Fr_2 (se albero uscita) valori indicati nelle tabelle dati tecnici del riduttore. Devono essere soddisfatte le seguenti relazioni:

$$Fr < Fr_1$$

I valori di Fr_1 ed Fr_2 riportati nelle tabelle dati tecnici sono riferiti a carichi agenti sulla mezzeria dell'albero sporgente. Nel caso in cui il carico sia applicato in una posizione diversa dalla mezzeria, è necessario valutarne l'effetto tramite le relazioni indicate nei paragrafi seguenti.

The radial load value obtained from the above equation is to be compared with the values of Fr_1 (in case of input shaft) or Fr_2 in case of output shaft, indicated in the gearbox technical data tables. The following equations must be satisfied:

$$Fr < Fr_2$$

The values of Fr_1 and Fr_2 given in the technical data tables refer to loads acting on the centre line of the extended shaft. If the load is applied at a position other than the centre line, its effect must be evaluated by using the equations given in the following paragraphs.

Fr2 (N)

Carichi radiali uscita / Output radial loads

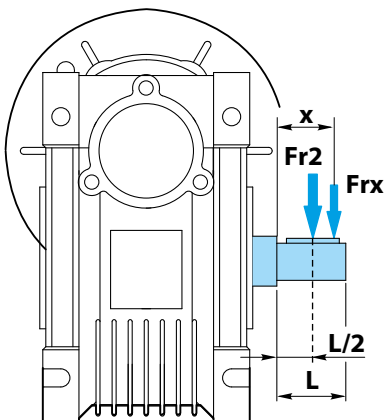

VP	025	030	040	050	063	075	090	110	130	150
a (mm)	50	65	84	101	120	131	162	176	188	215
b (mm)	38	50	64	76	95	101	122	136	148	174
Fr2max (N)	1350	1830	3490	4840	6270	7380	8180	12000	13500	18000

$$Fr_x = \frac{Fr_2 \cdot a}{(b + x)} < Fr_{2max}$$

a, b = valori riportati nella tabella
a, b = values given in the table

$$Fr < Fr_x$$

Fr₁ (N)

Carichi radiali entrata / Input radial loads

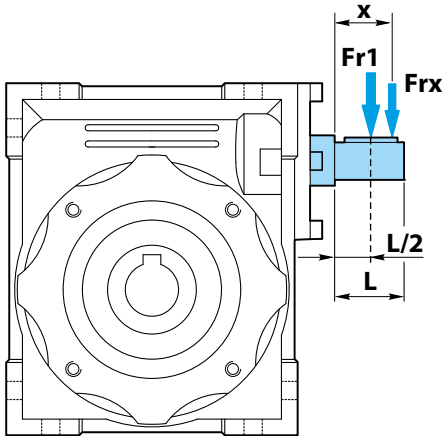

VI / VS	030	040	050	063	075	090	110	130	150
a (mm)	86	106	129	159	192	227	266	314	350
b (mm)	76	94.5	114	139	167	202	236	274	310
Fr _{1max} (N)	210	350	490	700	980	1270	1700	2100	2800

$$Fr_x = \frac{Fr_1 \cdot a}{(b + x)} < Fr_{1max}$$

a, b = valori riportati nella tabella
a, b = values given in the table

$$Fr < Fr_x$$

Fa₁ ; Fa₂ (N)

Carichi assiali / Axial loads

A seconda del tipo di applicazione, insieme al carico radiale può essere presente anche una forza Fa agente assialmente sull'albero (Fa₁ nel caso di albero entrata, Fa₂ nel caso di albero uscita).
Il carico assiale massimo applicabile sull'albero è da considerare pari a:

Depending on the type of application, along with the radial load there may also be a force Fa acting axially on the shaft (Fa₁ for the input shaft, Fa₂ for the output shaft).
The maximum axial load applicable to the shaft is to be considered equal to:

$$Fa_1 = Fr_1 \cdot 0.2$$

$$Fa_2 = Fr_2 \cdot 0.2$$

Senso di rotazione / Direction of rotation

VP / VI

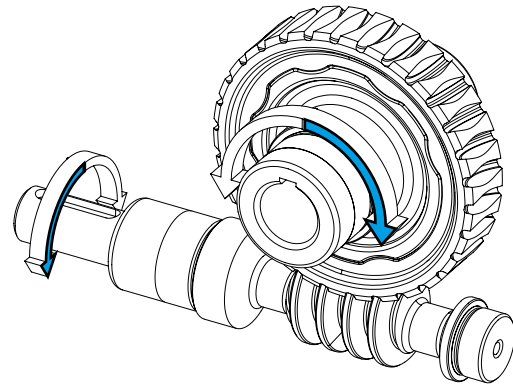
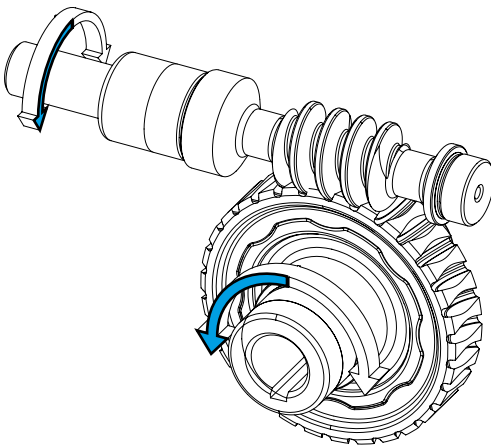

VC / VS

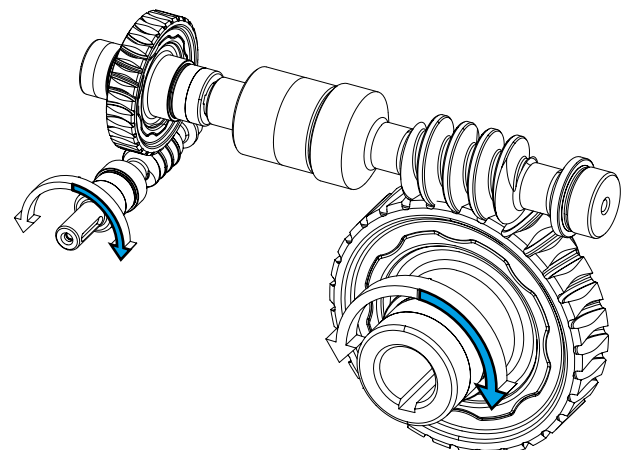
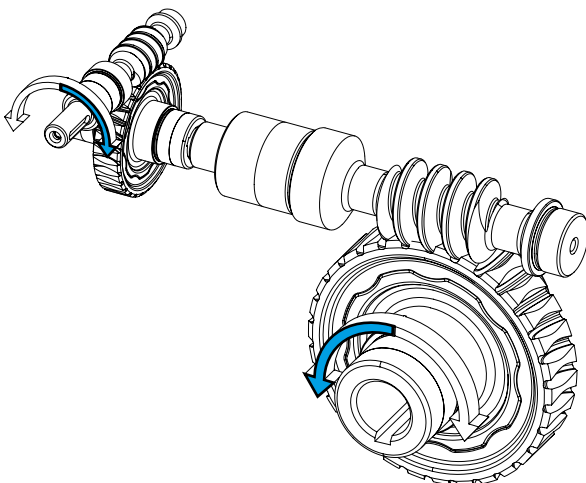

Selezione / Selection

Per definire il riduttore o motoriduttore idoneo per l'applicazione, come primo passo, è necessario individuare il valore del fattore di servizio f_s consigliato (consultando la relativa tabella) noti il ciclo di lavoro ed il tipo di carico.

To define the suitable gearbox or gearmotor for the application, as a first step, it is necessary to identify the recommended service factor f_s (referring to the relevant table) knowing the operating cycle and the type of load.

Scelta del riduttore / Selecting of gearbox

Nota la velocità in entrata al riduttore n_1 , dalle tabelle dati tecnici riduttore riferite a $n_1 = 1400 / 2800 / 900$ (min⁻¹), si individuerà il prodotto che, in corrispondenza di un rapporto di riduzione prossimo a quello calcolato, ammetta una coppia:

Knowing the gearbox input speed n_1 and using the gearbox technical data tables referring to $n_1 = 1400 / 2800 / 900$ (min⁻¹), you can identify the product that, at a reduction ratio close to the calculated one, permits a torque:

$$Mm_2 \geq Mr_2 \cdot f_s$$

 n_1 2800 min⁻¹

	n_2 (min ⁻¹)	Mm_2 (Nm)	Pm_1 (kW)	i	FR_2 (N)	FR_1 (N)
VI 090						
	373.3	210	9.0	7,5	2446	715
	280	235	7.7	10	2692	900
	186.7	270	6.0	15	3081	1034
	140	260	4.4	20	3391	1120
	112	250	3.4	25	3653	1270
	93.3	310	3.7	30	3882	1270
	70	275	2.6	40	4273	1270
	56	265	2.0	50	4603	1270
	46.7	245	1.6	60	4891	1270
	35	225	1.2	80	5383	1270

 n_1 1400 min⁻¹

	n_2 (min ⁻¹)	Mm_2 (Nm)	Pm_1 (kW)	i	FR_2 (N)	FR_1 (N)
VI 063/150						
	9.3	1971	2.81	150	18000	500
	7.0	2084	2.28	200	18000	595
	5.6	2050	1.84	250	18000	595
	4.7	2312	1.75	300	18000	660
	3.5	2670	1.70	400	18000	595
	2.8	2330	1.27	500	18000	595
	2.3	2670	1.18	600	18000	660
	1.9	2330	0.87	750	18000	660
	1.6	2100	0.62	900	18000	700
	1.2	2670	0.66	1200	18000	700
	0.8	2100	0.37	1800	18000	700
	0.6	2670	0.39	2400	18000	700
	0.5	2330	0.29	3000	18000	700
	0.4	2330	0.24	4000	18000	700
	0.3	2330	0.21	5000	18000	700

Scelta del motoriduttore / Selecting of gearmotor

1 - Se è nota la potenza motore P (kW) da applicare in ingresso al riduttore e richiesta dall'applicazione, si può passare direttamente alla consultazione delle tabelle dati tecnici motoriduttori (v. p.to 2).
In alternativa, se è nota la coppia richiesta in uscita dall'applicazione Mr_2 , è necessario determinare la potenza motore P con la formula:

$$P = \frac{Mr_2 \cdot n_2}{9550 \cdot Rd}$$

in cui n_2 è il numero di giri richiesti in uscita al motoriduttore ed Rd è il rendimento dinamico riportato nella relativa tabella.

2 - Consultando le tabelle dei dati tecnici dei motoriduttori, individuare la motorizzazione in cui Pn_1 risulti maggiore o uguale alla potenza P precedentemente calcolata. Con riferimento ad una velocità n_2 prossima a quella desiderata, individuare la motorizzazione in cui il fattore di servizio fs indicato sia maggiore o uguale a quello ricavato all'inizio del processo di selezione.

ESEMPIO:

Dati applicazione:
P = 0.09 kW
fs = 2
 $n_2 = 57 \text{ (min}^{-1}\text{)}$

Motoriduttore selezionato:
VP040 i=50 -- $Pn_1 = 0.09 \text{ kW}$ -- fs = 2.8

1 - Knowing the motor power P (kW) to be applied at the gearbox input and required by the application, you can directly refer to the technical data tables for the gearmotors (see point 2).
Alternatively, if the output torque required by the application Mr_2 is known, it is necessary to determine the motor power P with the formula:

where n_2 is the number of revolutions required at the gearmotor output and Rd is the dynamic efficiency given in the relevant table.

2 - Referring to the technical data tables for the gearmotors, identify the motor drive where Pn_1 is greater than or equal to the power P previously calculated. With reference to a speed n_2 close to the one you want, identify the motor drive where the indicated service factor fs is greater than or equal to that obtained at the beginning of the selection process.

EXAMPLE:

Application data:
P = 0.09 kW
fs = 2
 $n_2 = 57 \text{ (min}^{-1}\text{)}$

Selected gearmotor:
VP040 i=50 -- $Pn_1 = 0.09 \text{ kW}$ -- fs = 2.8

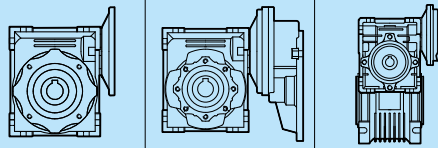
Pn_1 (kW)	n_2 (min ⁻¹)	M2 (Nm)	fs	i		FR_2 (N)
0.09						
MT 056 0.09 2 $n_1 = 2800 \text{ min}^{-1}$	56	9.4	1.4	50	VP030	1021
	56	11	2.8	50	VP040	1964
	46.7	11	0.7	60	VP025	798
	46.7	10	1.1	60	VP030	1085
	46.7	12	2.3	60	VP040	2087
	35	13	0.9	80	VP030	1194

Temperatura operativa / Operating temperature

Tutti i riduttori della nuova gamma SATI sono idonei ad operare fino ad una temperatura massima continuativa all'interno del riduttore di +85°C.

Gli anelli di tenuta sono in mescole acrilonitriliche.

Per temperature operative continuative più elevate di + 85°C, si richiede di consultare l'Ufficio Tecnico SATI per i suggerimenti del caso.
La temperatura minima a cui i riduttori possono operare è di -5°C.

in caso di ambiente di lavoro con temperatura <-5 °C o > +40°C, contattare servizio tecnico SATI.

All the gearboxes in the new SATI range are suitable to operate up to a maximum continuous temperature inside the gearbox of +85°C.

The shaft seals are made of acrylonitrile compounds.

For continuous operating temperatures higher than + 85°C, it is necessary to contact the SATI Engineering Department for advice.
The minimum temperature at which the gearboxes can operate is -5°C.

For ambient temperatures <-5°C or > +40°C, it is recommended to contact SATI technical service.

Verniciatura / Painting

Tutti i riduttori SATI sono verniciati a polveri epossidiche in colore grigio RAL 9006, ad esclusione delle parti lavorate per appoggi di fissaggio e accoppiamenti.

All SATI gearboxes are epoxy powder painted in the colour RAL 9006 grey, except for the machined parts, for fixing supports and couplings.

Installazione / Installation

In fase d'installazione si consiglia di:

- allineare correttamente il riduttore con il motore e l'utenza rispettando la corretta posizione di montaggio definita in fase d'ordine;
- verificare che eventuali organi di trasmissione montati sull'albero entrata o uscita del riduttore siano calettati correttamente così da non generare spinte superiori a quelle ammesse;
- controllare che i dati in targhetta corrispondano al prodotto selezionato
- verificare che l'ambiente di lavoro non sia corrosivo;
- verificare, nel caso dei riduttori dalla gr. 110 alla 150, la presenza della giusta quantità di lubrificante in funzione della posizione di montaggio e montare il tappo di sfiato nella posizione prevista;
- verificare che il senso di rotazione in uscita dal riduttore sia quello desiderato preventivamente al montaggio sull'applicazione;
- prevedere un avviamento graduale evitando l'applicazione della massima potenza;
- montare il riduttore stabilmente evitando qualsiasi vibrazione.

Pur potendo essere impiegati anche con motore a 2 poli, velocità in entrata di 2800 RPM, i riduttori a vite senza fine non sono in generale particolarmente indicati per un impiego ad alta velocità in entrata.

Nei limiti del possibile, si consiglia ai clienti di preferire motoriduttori a 4 oppure a 6 poli. Qualora si renda indispensabile l'utilizzo di un motoriduttore a 2 poli, si consiglia di attenersi scrupolosamente alle prestazioni indicate sul catalogo e possibilmente di scegliere un riduttore che abbia un fattore di servizio decisamente più alto di quello presunto per l'applicazione. L'impiego dei riduttori con motori 2 poli ed a 60 Hz è fortemente sconsigliato.

Sono inoltre sconsigliati:

- Impiego del riduttore come moltiplicatore
- Utilizzo del riduttore per argani di sollevamento ed in generale per applicazioni in cui è in gioco la sicurezza di persone o cose
- Applicazioni che prevedono una immersione parziale o totale del riduttore

Non fare mai affidamento sulla reale irreversibilità di un riduttore ed in caso di necessità impiegare motori auto frenanti o altri dispositivi di sicurezza. L'eventuale rottura di organi del riduttore non deve mai determinare rischi gravi per la sicurezza soprattutto di persone.

During installation it is recommended to:

- properly align the gearbox with the motor and the user and comply with the correct mounting position defined in the order;
- verify that any transmission components fitted on the input or output shaft of the gearbox are correctly locked, so as not to generate higher thrust loads than the acceptable ones;
- check that the name plate data match the selected product
- ensure that the work environment is not corrosive;
- verify, in the case of gearboxes from size 110 to 150, there is the correct amount of lubricant according to the mounting position and install the breather plug in the required position;
- Prior to installation on the application make sure that the direction of rotation at the gearbox output is the desired one;
- provide for a gradual start without applying the maximum power;
- fit the gearbox in a stable manner to avoid any vibration.

While worm gearboxes can also be used with a 2-pole motor, input speed of 2800 rpm, they are generally not particularly suitable for use at high input speed.

As far as possible, customers are recommended to prefer gearmotors with 4 or 6 poles. If it is necessary to use a 2-pole gearmotor, it is advisable to strictly comply with the performance indicated in the catalogue and preferably choose a gearbox that has a definitely higher service factor than the one assumed for the application.

Using gearboxes with 2-pole and 60 Hz motors is strongly discouraged.

It is also advised against:

- Using the gearbox as a multiplier
- Using the gearbox for hoisting winches and, generally, for applications where safety is at stake for people and property
- Applications involving a total or partial immersion of the gearbox

Never rely on the actual irreversibility of a gearbox and if necessary use brake motors or other safety devices.

Any breakage of parts of the gearbox must never result in serious risks for safety especially of people.

Identificazione / Identification

Tutti i riduttori SATI sono identificati da una targhetta contenente i dati relativi alla tipologia di prodotto a cui si riferiscono oltre che da un identificativo numerico per la rintracciabilità.

Si presti pertanto attenzione a non danneggiare né rimuovere tale etichetta.

Si riporta di seguito un esempio di targhetta.

All SATI gearboxes are identified by a name plate containing the data related to the type of product to which they refer, as well as numeric identification for traceability.

For the above reasons, take care that this name plate does never get damaged or removed.

An example of a name plate is given below.

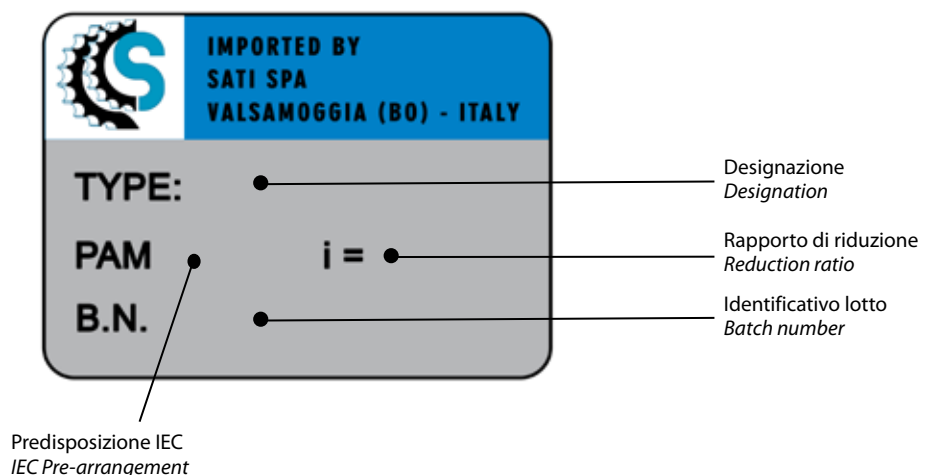

Predisposizioni IEC / IEC Pre-arrangements

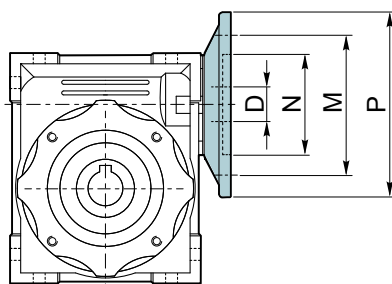

VP	IEC	N	M	P	D												
					R5	R7.5	R10	R15	R20	R25	R30	R40	R50	R60	R80	R100	
025	56B14	50	65	80	9	9	9	9	9	9	9	9	9	9	9	-	-
030	63B5	95	115	140	11	11	11	11	11	11	11	11	11	11	-	-	-
	63B14	60	75	90	9	9	9	9	9	9	9	9	9	9	9	9	-
	56B5	80	100	120	-	-	-	-	-	-	-	-	-	9	9	9	9
	56B14	50	65	80	9	9	9	9	9	9	9	9	9	9	9	9	9
040	71B5	110	130	160	14	14	14	14	14	14	14	14	14	-	-	-	-
	71B14	70	85	105	11	11	11	11	11	11	11	11	11	11	11	-	-
	63B5	95	115	140	-	-	-	-	-	-	-	-	-	9	9	9	9
	63B14	60	75	90	14	14	14	14	14	14	14	14	14	14	14	14	14
	56B5	80	100	120	-	-	-	-	-	-	-	-	-	9	9	9	9
050	80B5	130	165	200	19	19	19	19	19	19	19	19	-	-	-	-	-
	80B14	80	100	120	14	14	14	14	14	14	14	14	14	14	14	14	14
	71B5	110	130	160	-	-	-	-	-	-	-	-	11	11	11	11	11
	71B14	70	85	105	24	24	24	24	24	24	24	24	24	24	24	24	24
	63B5	95	115	140	-	19	19	19	19	19	19	19	19	19	19	19	19
063	90B5	130	165	200	-	14	14	14	14	14	14	14	14	14	14	14	14
	90B14	95	115	140	-	28	28	28	28	28	28	28	28	28	28	28	28
	80B5	130	165	200	-	19	19	19	19	19	19	19	19	19	19	19	19
	80B14	80	100	120	-	14	14	14	14	14	14	14	14	14	14	14	14
	71B5	110	130	160	-	24	24	24	24	24	24	24	24	24	24	24	24
	71B14	70	85	105	-	19	19	19	19	19	19	19	19	19	19	19	19
075	100/112B5	180	215	250	-	28	28	28	28	28	28	28	-	-	-	-	-
	100/112B14	110	130	160	-	14	14	14	14	14	14	14	14	14	14	14	14
	90B5	130	165	200	-	19	19	19	19	19	19	19	19	19	19	19	19
	90B14	95	115	140	-	24	24	24	24	24	24	24	24	24	24	24	24
	80B5	130	165	200	-	19	19	19	19	19	19	19	19	19	19	19	19
	80B14	80	100	120	-	14	14	14	14	14	14	14	14	14	14	14	14
	71B5	110	130	160	-	28	28	28	28	28	28	28	28	28	28	28	28
090	100/112B5	180	215	250	-	38	38	38	38	38	38	38	-	-	-	-	-
	100/112B14	110	130	160	-	14	14	14	14	14	14	14	14	14	14	14	14
	90B5	130	165	200	-	19	19	19	19	19	19	19	19	19	19	19	19
	90B14	95	115	140	-	24	24	24	24	24	24	24	24	24	24	24	24
	80B5	130	165	200	-	19	19	19	19	19	19	19	19	19	19	19	19
	80B14	80	100	120	-	14	14	14	14	14	14	14	14	14	14	14	14
110	132B5	230	265	300	-	38	38	38	38	38	38	38	-	-	-	-	-
	132 B14	130	165	200	-	14	14	14	14	14	14	14	14	14	14	14	14
	100/112B5	180	215	250	-	28	28	28	28	28	28	28	28	28	28	28	28
	90B5	130	165	200	-	19	19	19	19	19	19	19	19	19	19	19	19
	80B5	130	165	200	-	14	14	14	14	14	14	14	14	14	14	14	14
130	132B5	230	265	300	-	38	38	38	38	38	38	38	-	-	-	-	-
	132 B14	130	165	200	-	14	14	14	14	14	14	14	14	14	14	14	14
	100/112B5	180	215	250	-	28	28	28	28	28	28	28	28	28	28	28	28
	90B5	130	165	200	-	19	19	19	19	19	19	19	19	19	19	19	19
150	160B5	250	300	350	-	42	42	42	42	42	42	-	-	-	-	-	-
	132B5	230	265	300	-	38	38	38	38	38	38	38	38	38	38	38	38
	100/112B5	180	215	250	-	28	28	28	28	28	28	28	28	28	28	28	28

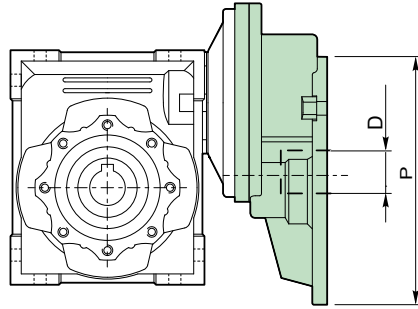
Predisposizioni IEC / IEC Pre-arrangements

IEC: P / D

i = R1 x R2		Grandezza precoppia / Size pre-stage			
Grandezza riduttore Size gearbox	R2	063	071	080	090
		IEC 140 / 11	IEC 160 / 14	IEC 200 / 19	IEC 200 / 24
		R1 = 2.94	R1 = 2.94	R1 = 3	R1 = 2.45
VR ... / 040	25	i = 73.5			
	30	i = 88.2			
	40	i = 117.5			
	50	i = 147			
	60	i = 176.4			
	80	i = 235.2			
	100	i = 294			
VR ... / 050	25		i = 73.5		
	30		i = 88.2		
	40	i = 117.5	i = 117.5		
	50	i = 147	i = 147		
	60	i = 176.4	i = 176.4		
	80	i = 235.2	i = 235.2		
	100	i = 294			
VR ... / 063	25				
	30				
	40		i = 117.5		
	50		i = 147		
	60		i = 176.4		
	80		i = 235.2		
	100		i = 294		
VR ... / 075	25			i = 75	
	30			i = 90	
	40			i = 120	
	50		i = 147	i = 150	
	60		i = 176.4	i = 180	
	80		i = 235.2	i = 240	
	100		i = 294	i = 300	
VR ... / 090	25				i = 61.2
	30				i = 73.5
	40			i = 120	i = 98
	50			i = 150	i = 122.5
	60			i = 180	i = 147
	80			i = 240	
	100			i = 300	
VR ... / 110	25				i = 61.2
	30				i = 73.5
	40				i = 98
	50				i = 122.5
	60				i = 147
	80			i = 240	i = 196
	100			i = 300	i = 245
VR ... / 130	25				
	30				
	40				
	50				
	60				
	80				i = 196
	100				i = 245

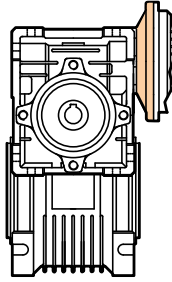
Predisposizioni IEC / IEC Pre-arrangements



$i = R1 \times R2$

R1 = Rapporto di riduzione riduttore entrata
Ratio input gearbox

R2 = Rapporto di riduzione riduttore uscita
Ratio output gearbox

VC	i	n2	IEC	R1	R2
025 / 030	100	14	56	10	10
	150	9.3		10	15
	200	7		10	20
	250	5.6		10	25
	300	4.7		10	30
	400	3.5		20	20
	500	2.8		20	25
	600	2.3		20	30
	750	1.9		30	25
	900	1.6		30	30
	1200	1.2		40	30
	1500	0.93		50	30
	1800	0.78		60	30
	2400	0.58		60	40
3000	0.47	60	50		
025 / 040	100	14	56	10	10
	150	9.3		10	15
	200	7		10	20
	250	5.6		10	25
	300	4.7		10	30
	400	3.5		10	40
	500	2.8		20	25
	600	2.3		20	30
	750	1.9		25	30
	900	1.6		30	30
	1200	1.2		40	30
	1500	0.93		50	30
	1800	0.78		60	30
	2400	0.58		60	40
3000	0.47	60	50		
4000	0.35	50	80		
5000	0.28	50	100		
030 / 040	100	14	56	10	10
	150	9.3		10	15
	200	7		10	20
	250	5.6		10	25
	300	4.7		10	30
	400	3.5		10	40
	500	2.8		20	25
	600	2.3		20	30
	750	1.9		30	25
	900	1.6		30	30
	1200	1.2		40	30
	1500	0.93		50	30
	1800	0.78		60	30
	2400	0.58		60	40
3000	0.47	50	80		
4000	0.35	50	80		
5000	0.28	50	100		
030 / 050	100	14	56 63	10	10
	150	9.3		10	15
	200	7		10	20
	250	5.6		10	25
	300	4.7		10	30
	400	3.5		10	40
	500	2.8		10	50
	600	2.3		20	30
	750	1.9		25	30
	900	1.6		30	30
	1200	1.2		40	30
	1500	0.93		50	30
	1800	0.78		60	30
	2400	0.58		60	40
3000	0.47	60	50		
4000	0.35	50	80		
4800	0.29	60	80		

VC	i	n2	IEC	R1	R2
030 / 063	100	14	56 63	10	10
	150	9.3		10	15
	200	7		10	20
	250	5.6		10	25
	300	4.7		10	30
	400	3.5		10	40
	500	2.8		10	50
	600	2.3		20	30
	750	1.9		25	30
	900	1.6		30	30
	1200	1.2		40	30
	1500	0.93		50	30
	1800	0.78		60	30
	2400	0.58		60	40
3000	0.47	60	50		
4000	0.35	50	80		
5000	0.29	50	100		
040 / 075 040 / 090	200	7	56 63	10	20
	250	5.6		10	25
	300	4.7		10	30
	400	3.5		10	40
	500	2.8		10	50
	600	2.3		20	30
	750	1.9		25	30
	900	1.6		30	30
	1200	1.2		40	30
	1500	0.93		50	30
	1800	0.78		60	30
	2400	0.58		60	40
	3000	0.47		60	50
	4000	0.35		80	50
5000	0.28	100	50		
050 / 110	100	14	63 71 80	10	10
	150	9.3		10	15
	200	7		10	20
	250	5.6		10	25
	300	4.7		10	30
	400	3.5		10	40
	500	2.8		20	25
	600	2.3		20	30
	750	1.9		25	30
	900	1.6		30	30
	1200	1.2		40	30
	1500	0.93		50	30
	1800	0.78		60	30
	2400	0.58		60	40
3000	0.47	60	50		
4000	0.35	80	50		
5000	0.28	100	50		
063 / 130 063 / 150	250	5.6	71 80 90	10	25
	300	4.7		10	30
	400	3.5		10	40
	500	2.8		10	50
	600	2.3		20	30
	750	1.9		25	30
	900	1.6		30	30
	1200	1.2		40	30
	1500	0.93		50	30
	1800	0.78		60	30
	2400	0.58		60	40
	3000	0.47		60	50
	4000	0.35		80	50
	5000	0.28		100	50

n_1 900 min⁻¹
Dati tecnici / Technical data

	n_2 (min ⁻¹)	Mm_2 (Nm)	Pm_1 (kW)	i	FR_2 (N)	FR_1 (N)
VI 030 / MRV030						
	180	20	0.44	5	692	175
	120	20	0.30	7.5	792	175
	90	20	0.24	10	871	197
	60	20	0.17	15	997	197
	45	20	0.13	20	1098	210
	36	23	0.14	25	1183	210
	30	21	0.11	30	1257	210
	22.5	20	0.09	40	1383	210
	18	18	0.07	50	1490	210
	15	17	0.06	60	1583	210
	11.3	15	0.04	80	1743	210
VI 040 / MRV040						
	180	44	0.87	5	1331	290
	120	44	0.66	7.5	1524	319
	90	44	0.51	10	1677	350
	60	45	0.36	15	1920	350
	45	44	0.28	20	2113	350
	36	43	0.23	25	2276	350
	30	49	0.23	30	2419	350
	22.5	45	0.17	40	2662	350
	18	42	0.14	50	2868	350
	15	39	0.11	60	3047	350
	11.3	35	0.09	80	3354	350
	9	32	0.07	100	3490	350
VI 050 / MRV050						
	180	75	1.6	5	1827	400
	120	84	1.2	7.5	2091	448
	90	84	0.95	10	2302	490
	60	84	0.67	15	2635	490
	45	77	0.48	20	2900	490
	36	75	0.39	25	3124	490
	30	90	0.42	30	3320	490
	22.5	82	0.31	40	3654	490
	18	77	0.25	50	3936	490
	15	72	0.21	60	4183	490
	11.3	68	0.16	80	4604	490
	9	56	0.12	100	4840	490
VI 063 / MRV063						
	120	151	2.2	7.5	2734	580
	90	153	1.7	10	3009	661
	60	155	1.2	15	3444	670
	45	148	0.91	20	3791	700
	36	137	0.70	25	4084	700
	30	175	0.79	30	4339	700
	22.5	160	0.58	40	4776	700
	18	145	0.45	50	5145	700
	15	138	0.37	60	5467	700
	11.3	128	0.29	80	6018	700
	9	124	0.25	100	6270	700
VI 075 / MRV075						
	120	215	3.1	7.5	3227	810
	90	230	2.6	10	3551	975
	60	235	1.8	15	4065	980
	45	235	1.4	20	4474	980
	36	215	1.1	25	4820	980
	30	260	1.2	30	5122	980
	22.5	240	0.84	40	5637	980
	18	220	0.66	50	6073	980
	15	210	0.55	60	6453	980
	11.3	200	0.43	80	7103	980
	9	190	0.36	100	7380	980

n_1 900 min⁻¹

Dati tecnici / Technical data

	n_2 (min ⁻¹)	Mm_2 (Nm)	Pm_1 (kW)	i	FR_2 (N)	FR_1 (N)
VI 090 / MRV090						
	120	340	4.9	7,5	3570	1040
	90	370	4.1	10	3929	1270
	60	420	3.2	15	4498	1270
	45	390	2.3	20	4951	1270
	36	370	1.8	25	5333	1270
	30	460	1.9	30	5667	1270
	22.5	410	1.4	40	6238	1270
	18	390	1.1	50	6719	1270
	15	350	0.86	60	7140	1270
	11.3	315	0.63	80	7859	1270
	9	280	0.49	100	8180	1270
VI 110 / MRV110						
	120	650	9.3	7.5	4511	1390
	90	713	7.7	10	4965	1700
	60	759	5.7	15	5684	1700
	45	725	4.1	20	6256	1700
	36	759	3.5	25	6739	1700
	30	840	3.5	30	7161	1700
	22.5	794	2.5	40	7882	1700
	18	748	2.0	50	8491	1700
	15	682	1.6	60	9023	1700
	11.3	567	1.1	80	9931	1700
	9	515	0.82	100	10320	1700
VI 130 / MRV130						
	120	880	12.4	7.5	5901	1740
	90	960	10.4	10	6494	2100
	60	1060	7.8	15	7434	2100
	45	1040	5.9	20	8182	2100
	36	1050	4.9	25	8814	2100
	30	1170	4.8	30	9366	2100
	22.5	1100	3.5	40	10309	2100
	18	1050	2.8	50	11105	2100
	15	940	2.1	60	11801	2100
	11.3	860	1.6	80	12989	2100
	9	780	1.2	100	13500	2100
VI 150 / MRV130						
	120	1400	19.6	7.5	8067	2270
	90	1480	15.7	10	8878	2700
	60	1450	10.5	15	10163	2645
	45	1500	8.3	20	11186	2800
	36	1380	6.2	25	12050	2800
	30	1400	5.4	30	12805	2800
	22.5	1800	5.6	40	14094	2800
	18	1600	4.1	50	15182	2800
	15	1440	3.2	60	16133	2800
	11.3	1300	2.3	80	17757	2800
	9	1150	1.8	100	18000	2800

n_1 1400 min⁻¹
Dati tecnici / Technical data

	n_2 (min ⁻¹)	Mm_2 (Nm)	Pm_1 (kW)	i	FR_2 (N)	FR_1 (N)
VI 030 / MRV030						
	280	18	0.61	5	597	150
	186.7	18	0.4	7.5	683	150
	140	18	0.3	10	752	948
	93.3	18	0.2	15	861	1021
	70	18	0.2	20	948	1085
	56	21	0.2	25	1021	1194
	46.7	20	0.2	30	1085	1286
	35	18	0.1	40	1194	1367
	28	17	0.1	50	1286	1504
	23.3	16	0.1	60	1367	1315
	17.5	13	0.1	80	1504	1447
VI 040 / MRV040						
	280	34	1.1	5	1149	250
	186.7	40	0.9	7.5	1315	294
	140	40	0.7	10	1447	1824
	93.3	40	0.5	15	1657	1964
	70	39	0.4	20	1824	2087
	56	38	0.3	25	1964	2298
	46.7	45	0.3	30	2087	2475
	35	41	0.2	40	2298	2630
	28	39	0.2	50	2475	2895
	23.3	36	0.2	60	2630	3118
	17.5	33	0.1	80	2895	1805
	14	29	0.1	100	3118	1987
VI 050 / MRV050						
	280	62	2.0	5	1577	350
	186.7	71	1.6	7.5	1805	401
	140	72	1.2	10	1987	2503
	93.3	74	0.9	15	2274	2696
	70	73	0.7	20	2503	2865
	56	70	0.5	25	2696	3153
	46.7	84	0.6	30	2865	3397
	35	76	0.4	40	3153	3610
	28	73	0.3	50	3397	3973
	23.3	68	0.3	60	3610	4280
	17.5	65	0.2	80	3973	2359
	14	55	0.2	100	4280	2597
VI 063 / MRV063						
	186.7	128	2.8	7.5	2359	500
	140	130	2.2	10	2597	3272
	93.3	140	1.7	15	2973	3524
	70	135	1.2	20	3272	3745
	56	130	1.0	25	3524	4122
	46.7	160	1.1	30	3745	4440
	35	145	0.8	40	4122	4719
	28	135	0.6	50	4440	5193
	23.3	130	0.5	60	4719	5595
	17.5	122	0.4	80	5193	2785
	14	118	0.3	100	5595	3065
VI 075 / MRV075						
	186.7	185	4.1	7.5	2785	700
	140	195	3.3	10	3065	3862
	93.3	200	2.3	15	3509	4160
	70	210	1.9	20	3862	4421
	56	200	1.5	25	4160	4865
	46.7	230	1.5	30	4421	5241
	35	220	1.1	40	4865	5569
	28	210	0.9	50	5241	6130
	23.3	200	0.8	60	5569	6603
	17.5	190	0.6	80	6130	0
	14	180	0.5	100	6603	0

n_1 1400 min⁻¹

Dati tecnici / Technical data

	n_2 (min ⁻¹)	Mm_2 (Nm)	Pm_1 (kW)	i	FR_2 (N)	FR_1 (N)
VI 090 / MRV090						
	186.7	290	6.4	7,5	3081	900
	140	310	5.2	10	3391	1082
	93.3	360	4.1	15	3882	1257
	70	355	3.1	20	4273	1270
	56	340	2.5	25	4603	1270
	46.7	410	2.6	30	4891	1270
	35	360	1.8	40	5383	1270
	28	340	1.4	50	5799	1270
	23.3	320	1.1	60	6163	1270
	17.5	285	0.8	80	6783	1270
	14	270	0.7	100	7306	1270
VI 110 / MRV110						
	186.7	552	12.1	7.5	3893	1200
	140	598	10.0	10	4285	1463
	93.3	656	7.5	15	4905	1604
	70	644	5.6	20	5399	1700
	56	679	4.8	25	5816	1700
	46.7	725	4.5	30	6181	1700
	35	702	3.3	40	6803	1700
	28	660	2.6	50	7328	1700
	23.3	616	2.1	60	7787	1700
	17.5	515	1.4	80	8571	1700
	14	483	1.1	100	9232	1700
VI 130 / MRV130						
	186.7	750	16.3	7.5	5092	1500
	140	820	13.5	10	5605	1845
	93.3	920	10.3	15	6416	2070
	70	910	7.8	20	7062	2100
	56	930	6.5	25	7607	2100
	46.7	1040	6.4	30	8084	2100
	35	1050	4.9	40	8897	2100
	28	980	3.8	50	9584	2100
	23.3	900	3.0	60	10185	2100
	17.5	840	2.3	80	11210	2100
	14	740	1.7	100	12076	2100
VI 150 / MRV150						
	186.7	1200	25.8	7.5	6962	1950
	140	1240	20.2	10	7663	2267
	93.3	1250	13.9	15	8771	2285
	70	1300	11.0	20	9654	2674
	56	1200	8.3	25	10400	2800
	46.7	1200	7.0	30	11051	2800
	35	1550	7.2	40	12163	2800
	28	1400	5.3	50	13103	2800
	23.3	1260	4.2	60	13924	2800
	17.5	1150	3.1	80	15325	2800
	14	1000	2.3	100	16508	2800

n_1 2800 min⁻¹
Dati tecnici / Technical data

	n_2 (min ⁻¹)	Mm_2 (Nm)	Pm_1 (kW)	i	FR_2 (N)	FR_1 (N)
VI 030 / MRV030						
	560	10	0.65	5	450	90
	373.3	13	0.58	7,5	542	125
	280	13	0.45	10	597	140
	186.7	13	0.32	15	683	140
	140	12	0.23	20	752	146
	112	16	0.26	25	810	210
	93.3	15	0.21	30	861	210
	70	14	0.16	40	948	127
	56	13	0.12	50	1021	128
	46.7	12	0.10	60	1085	126
	35	11	0.08	80	1194	130
VI 040 / MRV040						
	560	25	1.6	5	900	170
	373.3	28	1.2	7.5	1044	233
	280	29	1.0	10	1149	272
	186.7	31	0.72	15	1315	291
	140	29	0.52	20	1447	204
	112	28	0.42	25	1559	236
	93.3	34	0.44	30	1657	350
	70	31	0.32	40	1824	350
	56	30	0.26	50	1964	350
	46.7	28	0.21	60	2087	350
	35	25	0.16	80	2298	350
	28	23	0.12	100	2475	350
VI 050 / MRV050						
	560	43	2.8	5	1200	240
	373.3	52	2.3	7.5	1433	324
	280	54	1.8	10	1577	378
	186.7	57	1.3	15	1805	399
	140	53	0.95	20	1987	417
	112	51	0.75	25	2140	482
	93.3	64	0.81	30	2274	490
	70	59	0.59	40	2503	490
	56	53	0.45	50	2696	490
	46.7	50	0.37	60	2865	490
	35	45	0.27	80	3153	490
	28	40	0.21	100	3397	490
VI 063 / MRV063						
	373.3	93	4.0	7.5	1873	395
	280	97	3.2	10	2061	463
	186.7	103	2.3	15	2359	492
	140	100	1.7	20	2597	538
	112	92	1.3	25	2797	593
	93.3	120	1.5	30	2973	700
	70	108	1.1	40	3272	700
	56	100	0.81	50	3524	700
	46.7	95	0.67	60	3745	700
	35	85	0.49	80	4122	700
	28	74	0.37	100	4440	700
VI 075 / MRV075						
	373.3	130	5.7	7.5	2210	560
	280	145	4.8	10	2433	703
	186.7	150	3.4	15	2785	727
	140	160	2.8	20	3065	872
	112	150	2.1	25	3302	980
	93.3	170	2.1	30	3509	980
	70	165	1.6	40	3862	980
	56	150	1.2	50	4160	980
	46.7	145	1.0	60	4421	980
	35	130	0.72	80	4865	980
	28	120	0.57	100	5241	980

n_1 2800 min⁻¹

Dati tecnici / Technical data

	n_2 (min ⁻¹)	Mm_2 (Nm)	Pm_1 (kW)	i	FR_2 (N)	FR_1 (N)
VI 090 / MRV090						
	373.3	210	9.0	7,5	2446	715
	280	235	7.7	10	2692	900
	186.7	270	6.0	15	3081	1034
	140	260	4.4	20	3391	1120
	112	250	3.4	25	3653	1270
	93.3	310	3.7	30	3882	1270
	70	275	2.6	40	4273	1270
	56	265	2.0	50	4603	1270
	46.7	245	1.6	60	4891	1270
	35	225	1.2	80	5383	1270
	28	200	0.9	100	5799	1270
VI 110 / MRV110						
	373.3	391	16.8	7.5	3090	950
	280	437	14.2	10	3401	1194
	186.7	489	10.9	15	3893	1337
	140	483	8.1	20	4285	1485
	112	506	6.9	25	4616	1700
	93.3	552	6.5	30	4905	1700
	70	529	4.8	40	5399	1700
	56	495	3.7	50	5816	1700
	46.7	473	3.0	60	6181	1700
	35	399	2.0	80	6803	1700
	28	368	1.5	100	7328	1700
VI 130 / MRV130						
	373.3	520	22.3	7.5	4042	1190
	280	580	18.9	10	4449	1493
	186.7	670	14.7	15	5092	1725
	140	660	11.0	20	5605	1912
	112	670	9.1	25	6038	2100
	93.3	770	9.0	30	6416	2100
	70	730	6.5	40	7062	2100
	56	700	5.1	50	7607	2100
	46.7	640	4.0	60	8084	2100
	35	590	2.9	80	8897	2100
	28	520	2.2	100	9584	2100
VI 150 / MRV150						
	373.3	840	35.7	7.5	5526	1550
	280	890	28.4	10	6082	1848
	186.7	910	19.8	15	6962	1889
	140	980	16.0	20	7663	2289
	112	890	11.9	25	8254	2494
	93.3	920	10.3	30	8771	2800
	70	1200	10.5	40	9654	2800
	56	1100	8.0	50	10400	2800
	46.7	990	6.1	60	11051	2800
	35	920	4.5	80	12163	2800
	28	810	3.3	100	13103	2800

n_1 900 min⁻¹
Dati tecnici / Technical data

	n_2 (min ⁻¹)	Mm_2 (Nm)	Pm_1 (kW)	i	FR_2 (N)	FR_1 (N)
VS 030/040						
	9.0	71	0.11	100	2769	197
	6.0	72	0.08	150	3169	197
	4.5	65	0.05	200	3488	197
	3.6	61	0.04	250	3490	197
	3.0	73	0.05	300	3490	197
	2.3	65	0.04	400	3490	197
	1.8	61	0.02	500	3490	210
	1.5	73	0.03	600	3490	210
	1.2	73	0.02	750	3490	210
	1.0	73	0.02	900	3490	210
	0.8	73	0.02	1200	3490	210
	0.6	73	0.01	1500	3490	210
	0.5	73	0.01	1800	3490	210
	0.4	65	0.01	2400	3490	210
	0.3	60	0.01	3000	3490	210
	0.2	48	0.01	4000	3490	210
	0.2	43	0.00	5000	3490	210
VS 030/050						
	9.0	137	0.20	100	3800	197
	6.0	135	0.14	150	4350	197
	4.5	120	0.10	200	4788	197
	3.6	110	0.08	250	4840	197
	3.0	145	0.09	300	4840	197
	2.3	124	0.07	400	4840	197
	1.8	120	0.06	500	4840	197
	1.5	145	0.05	600	4840	210
	1.2	145	0.05	750	4840	210
	1.0	145	0.04	900	4840	210
	0.8	145	0.03	1200	4840	210
	0.6	145	0.03	1500	4840	210
	0.5	145	0.03	1800	4840	210
	0.4	124	0.02	2400	4840	210
	0.3	120	0.02	3000	4840	210
	0.2	82	0.01	4000	4840	210
	0.2	79	0.01	4800	4840	210
VS 030/063						
	9.0	166	0.24	100	4967	197
	6.0	233	0.24	150	5686	197
	4.5	253	0.21	200	6259	197
	3.6	231	0.16	250	6270	197
	3.0	255	0.17	300	6270	175
	2.3	255	0.13	400	6270	197
	1.8	236	0.11	500	6270	197
	1.5	271	0.10	600	6270	210
	1.2	271	0.09	750	6270	210
	1.0	271	0.08	900	6270	210
	0.8	271	0.06	1200	6270	210
	0.6	271	0.05	1500	6270	210
	0.5	271	0.05	1800	6270	210
	0.4	255	0.04	2400	6270	210
	0.3	236	0.03	3000	6270	210
	0.2	236	0.03	4000	6270	210
	0.2	150	0.01	5000	6270	210

n_1 900 min⁻¹

Dati tecnici / Technical data

	n_2 (min ⁻¹)	Mm_2 (Nm)	Pm_1 (kW)	i	FR_2 (N)	FR_1 (N)
VS 040/075						
	3	449	0.28	300	7380	350
	2.3	414	0.21	400	7380	350
	1.8	368	0.16	500	7380	350
	1.5	449	0.16	600	7380	350
	1.2	449	0.14	750	7380	350
	1	449	0.13	900	7380	350
	0.8	414	0.10	1200	7380	350
	0.6	449	0.09	1500	7380	350
	0.5	449	0.08	1800	7380	350
	0.4	414	0.06	2400	7380	350
	0.3	368	0.04	3000	7380	350
	0.2	288	0.03	4000	7380	350
	0.2	265	0.02	5000	7380	350
VS 040/090						
	3	689	0.41	300	8180	350
	2.3	689	0.33	400	8180	350
	1.8	633	0.25	500	8180	350
	1.5	689	0.23	600	8180	350
	1.2	633	0.18	750	8180	350
	1	571	0.15	900	8180	350
	0.8	689	0.15	1200	8180	350
	0.6	633	0.12	1500	8180	350
	0.5	571	0.09	1800	8180	350
	0.4	689	0.09	2400	8180	350
	0.3	633	0.07	3000	8180	350
	0.2	520	0.05	4000	8180	350
	0.2	463	0.04	5000	8180	350
VS 050/110						
	9.0	754	1.02	100	8198	490
	6.0	1090	1.02	150	9384	490
	4.5	1139	0.82	200	10320	490
	3.6	1173	0.69	250	10320	490
	3.0	1265	0.70	300	10320	490
	2.3	1185	0.51	400	10320	490
	1.8	1173	0.38	500	10320	490
	1.5	1265	0.39	600	10320	490
	1.2	1265	0.32	750	10320	490
	1.0	1265	0.29	900	10320	490
	0.8	1265	0.23	1200	10320	490
	0.6	1265	0.20	1500	10320	490
	0.5	1265	0.18	1800	10320	490
	0.4	1185	0.13	2400	10320	490
	0.3	1100	0.10	3000	10320	490
	0.2	1100	0.08	4000	10320	490
	0.2	1100	0.07	5000	10320	490
VS 063/130						
	9.0	1270	1.70	100	10722	661
	6.0	1700	1.61	150	12274	661
	4.5	1600	1.15	200	13500	661
	3.6	1530	0.90	250	13500	661
	3.0	1760	0.96	300	13500	661
	2.3	1650	0.70	400	13500	661
	1.8	1550	0.55	500	13500	661
	1.5	1760	0.52	600	13500	700
	1.2	1760	0.43	750	13500	700
	1.0	1760	0.38	900	13500	700
	0.8	1760	0.31	1200	13500	700
	0.6	1760	0.26	1500	13500	700
	0.5	1760	0.23	1800	13500	700
	0.4	1650	0.17	2400	13500	700
	0.3	1550	0.13	3000	13500	700
	0.2	1550	0.11	4000	13500	700
	0.2	1550	0.10	5000	13500	700

n_1 900 min⁻¹
Dati tecnici / Technical data

	n_2 (min ⁻¹)	Mm_2 (Nm)	Pm_1 (kW)	i	FR_2 (N)	FR_1 (N)
VS 063/150						
	6.0	2325	2.16	150	18000	580
	4.5	2340	1.68	200	18000	661
	3.6	2050	1.21	250	18000	661
	3.0	2340	1.16	300	18000	700
	2.3	2670	1.12	400	18000	661
	1.8	2330	0.83	500	18000	661
	1.5	2670	0.77	600	18000	700
	1.2	2330	0.58	750	18000	700
	1.0	2100	0.42	900	18000	700
	0.8	2670	0.45	1200	18000	700
	0.5	2100	0.26	1800	18000	700
	0.4	2670	0.27	2400	18000	700
	0.3	2330	0.20	3000	18000	700
	0.2	2330	0.17	4000	18000	700
	0.2	2330	0.15	5000	18000	700

n_1 1400 min⁻¹

Dati tecnici / Technical data

	n_2 (min ⁻¹)	Mm_2 (Nm)	Pm_1 (kW)	i	FR_2 (N)	FR_1 (N)
VS 030/040						
	14.0	71	0.16	100	2769	169
	9.3	72	0.12	150	3169	169
	7.0	65	0.08	200	3488	169
	5.6	61	0.07	250	3490	169
	4.7	73	0.07	300	3490	210
	3.5	65	0.06	400	3490	210
	2.8	61	0.04	500	3490	210
	2.3	73	0.05	600	3490	210
	1.9	73	0.04	750	3490	210
	1.6	73	0.04	900	3490	210
	1.2	65	0.03	1200	3490	210
	0.9	73	0.03	1500	3490	210
	0.8	73	0.02	1800	3490	210
	0.6	65	0.02	2400	3490	210
	0.5	60	0.01	3200	3490	210
	0.4	48	0.01	4000	3490	210
	0.3	43	0.01	5000	3490	210
VS 030/050						
	14.0	137	0.31	100	3800	169
	9.3	135	0.22	150	4350	169
	7.0	120	0.15	200	4788	169
	5.6	110	0.12	250	4840	169
	4.7	145	0.14	300	4840	169
	3.5	124	0.10	400	4840	169
	2.8	120	0.08	500	4840	169
	2.3	145	0.08	600	4840	180
	1.9	145	0.07	750	4840	210
	1.6	145	0.06	900	4840	210
	1.2	145	0.05	1200	4840	210
	0.9	145	0.04	1500	4840	210
	0.8	145	0.04	1800	4840	210
	0.6	124	0.03	2400	4840	210
	0.5	120	0.02	3000	4840	210
	0.4	82	0.01	4000	4840	210
	0.3	79	0.01	4800	4840	210
VS 030/063						
	14.0	150	0.34	100	4967	169
	9.3	211	0.34	150	5686	169
	7.0	253	0.32	200	6259	169
	5.6	231	0.24	250	6270	169
	4.7	255	0.26	300	6270	150
	3.5	255	0.20	400	6270	169
	2.8	236	0.16	500	6270	169
	2.3	271	0.15	600	6270	180
	1.9	271	0.13	750	6270	210
	1.6	271	0.11	900	6270	210
	1.2	271	0.09	1200	6270	210
	0.9	271	0.08	1500	6270	210
	0.8	271	0.07	1800	6270	210
	0.6	255	0.05	2400	6270	210
	0.5	236	0.04	3000	6270	210
	0.4	236	0.04	4000	6270	210
	0.3	150	0.02	5000	6270	210

n_1 1400 min⁻¹
Dati tecnici / Technical data

	n_2 (min ⁻¹)	Mm_2 (Nm)	Pm_1 (kW)	i	FR_2 (N)	FR_1 (N)
VS 040/075						
	4.7	390	0.38	300	7380	350
	3.5	360	0.28	400	7380	350
	2.8	320	0.21	500	7380	350
	2.3	390	0.21	600	7380	350
	1.9	390	0.19	750	7380	350
	1.6	390	0.17	900	7380	350
	1.2	360	0.13	1200	7380	350
	0.9	390	0.12	1500	7380	350
	0.8	390	0.11	1800	7380	350
	0.6	360	0.08	2400	7380	350
	0.5	320	0.06	3000	7380	350
	0.4	250	0.04	4000	7380	350
	0.3	230	0.03	5000	7380	350
VS 040/090						
	4.7	610	0.56	300	8180	350
	3.5	610	0.45	400	8180	350
	2.8	560	0.35	500	8180	350
	2.3	610	0.31	600	8180	350
	1.9	560	0.25	750	8180	350
	1.6	505	0.21	900	8180	350
	1.2	610	0.20	1200	8180	350
	0.9	560	0.16	1500	8180	350
	0.8	505	0.13	1800	8180	350
	0.6	610	0.12	2400	8180	350
	0.5	560	0.10	3000	8180	350
	0.4	460	0.07	4000	8180	350
	0.3	410	0.05	5000	8180	350
VS 050/110						
	14.0	648	1.33	100	8198	490
	9.3	936	1.33	150	9384	490
	7.0	1139	1.25	200	10320	490
	5.6	1173	1.05	250	10320	490
	4.7	1265	1.06	300	10320	490
	3.5	1185	0.77	400	10320	490
	2.8	1173	0.57	500	10320	490
	2.3	1265	0.58	600	10320	490
	1.9	1265	0.48	750	10320	490
	1.6	1265	0.42	900	10320	490
	1.2	1265	0.34	1200	10320	490
	0.9	1265	0.29	1500	10320	490
	0.8	1265	0.26	1800	10320	490
	0.6	1185	0.19	2400	10320	490
	0.5	1100	0.14	3000	10320	490
	0.4	1100	0.12	4000	10320	490
	0.3	1100	0.10	5000	10320	490
VS 063/130						
	14.0	1123	2.28	100	10722	595
	9.3	1584	2.28	150	12274	595
	7.0	1600	1.75	200	13500	595
	5.6	1530	1.37	250	13500	595
	4.7	1760	1.45	300	13500	595
	3.5	1650	1.07	400	13500	595
	2.8	1550	0.84	500	13500	595
	2.3	1760	0.77	600	13500	700
	1.9	1760	0.64	750	13500	700
	1.6	1760	0.56	900	13500	700
	1.2	1760	0.45	1200	13500	700
	0.9	1760	0.38	1500	13500	700
	0.8	1760	0.33	1800	13500	700
	0.6	1650	0.25	2400	13500	700
	0.5	1550	0.19	3000	13500	700
	0.4	1550	0.16	4000	13500	700
	0.3	1550	0.14	5000	13500	700

n_1 1400 min⁻¹

Dati tecnici / Technical data

	n_2 (min ⁻¹)	Mm_2 (Nm)	Pm_1 (kW)	i	FR_2 (N)	FR_1 (N)
VS 063/150						
	9.3	1971	2.81	150	18000	500
	7.0	2084	2.28	200	18000	595
	5.6	2050	1.84	250	18000	595
	4.7	2312	1.75	300	18000	660
	3.5	2670	1.70	400	18000	595
	2.8	2330	1.27	500	18000	595
	2.3	2670	1.18	600	18000	660
	1.9	2330	0.87	750	18000	660
	1.6	2100	0.62	900	18000	700
	1.2	2670	0.66	1200	18000	700
	0.8	2100	0.37	1800	18000	700
	0.6	2670	0.39	2400	18000	700
	0.5	2330	0.29	3000	18000	700
	0.4	2330	0.24	4000	18000	700
	0.3	2330	0.21	5000	18000	700

n_1 2800 min⁻¹
Dati tecnici / Technical data

	n_2 (min ⁻¹)	Mm_2 (Nm)	Pm_1 (kW)	i	FR_2 (N)	FR_1 (N)
VS 030/040						
	28.0	71	0.31	100	2769	140
	18.7	72	0.22	150	3169	140
	14.0	65	0.16	200	3488	140
	11.2	61	0.13	250	3490	140
	9.3	73	0.14	300	3490	140
	7.0	65	0.10	400	3490	140
	5.6	61	0.07	500	3490	146
	4.7	73	0.08	600	3490	146
	3.7	73	0.06	750	3490	210
	3.1	73	0.06	900	3490	210
	2.3	73	0.05	1200	3490	127
	1.9	73	0.04	1500	3490	128
	1.6	73	0.03	1800	3490	126
	1.2	65	0.03	2400	3490	126
	0.9	60	0.02	3000	3490	126
	0.7	48	0.01	4000	3490	128
	0.6	43	0.01	5000	3490	128
VS 030/050						
	28.0	103	0.44	100	3800	140
	18.7	135	0.42	150	4350	140
	14.0	120	0.30	200	4788	140
	11.2	110	0.23	250	4840	140
	9.3	145	0.27	300	4840	140
	7.0	124	0.20	400	4840	140
	5.6	120	0.16	500	4840	140
	4.7	145	0.15	600	4840	146
	3.7	145	0.13	750	4840	210
	3.1	145	0.11	900	4840	210
	2.3	145	0.09	1200	4840	127
	1.9	145	0.07	1500	4840	128
	1.6	145	0.07	1800	4840	126
	1.2	124	0.05	2400	4840	126
	0.9	120	0.04	3000	4840	126
	0.7	82	0.02	4000	4840	128
	0.6	79	0.02	4800	4840	128
VS 030/063						
	28.0	103	0.44	100	4967	140
	18.7	144	0.44	150	5686	140
	14.0	182	0.44	200	6259	140
	11.2	218	0.44	250	6270	140
	9.3	255	0.51	300	6270	125
	7.0	255	0.39	400	6270	140
	5.6	236	0.31	500	6270	140
	4.7	220	0.22	600	6270	146
	3.7	271	0.23	750	6270	210
	3.1	271	0.20	900	6270	210
	2.3	256	0.15	1200	6270	127
	1.9	238	0.12	1500	6270	128
	1.6	220	0.10	1800	6270	126
	1.2	255	0.09	2400	6270	126
	0.9	236	0.08	3000	6270	126
	0.7	236	0.06	4000	6270	130
	0.6	150	0.04	5000	6270	128
VS 040/075						
	9.3	316	0.62	300	7380	350
	7	292	0.45	400	7380	350
	5.6	259	0.34	500	7380	350
	4.7	316	0.34	600	7380	350
	3.7	316	0.31	750	7380	350
	3.1	316	0.28	900	7380	350
	2.3	310	0.22	1200	7380	350
	1.9	335	0.21	1500	7380	350
	1.6	335	0.19	1800	7380	350
	1.2	310	0.14	2400	7380	350
	0.9	282	0.11	3000	7380	350
	0.7	220	0.07	4000	7380	350
	0.6	202	0.05	5000	7380	350

n_1 2800 min⁻¹

Dati tecnici / Technical data

	n_2 (min ⁻¹)	Mm_2 (Nm)	Pm_1 (kW)	i	FR_2 (N)	FR_1 (N)
VS 040/090						
	9.3	500	0.92	300	8180	350
	7	500	0.74	400	8180	350
	5.6	459	0.57	500	8180	350
	4.7	500	0.51	600	8180	350
	3.7	459	0.41	750	8180	350
	3.1	414	0.34	900	8180	350
	2.3	500	0.33	1200	8180	350
	1.9	459	0.26	1500	8180	350
	1.6	414	0.21	1800	8180	350
	1.2	500	0.20	2400	8180	350
	0.9	459	0.16	3000	8180	350
	0.7	377	0.11	4000	8180	350
	0.6	336	0.08	5000	8180	350
VS 050/110						
	28.0	443	1.78	100	8198	378
	18.7	640	1.78	150	9384	378
	14.0	832	1.78	200	10320	378
	11.2	1013	1.78	250	10320	378
	9.3	1085	1.78	300	10320	378
	7.0	1185	1.50	400	10320	378
	5.6	994	0.94	500	10320	417
	4.7	1065	0.94	600	10320	417
	3.7	1025	0.74	750	10320	482
	3.1	1265	0.80	900	10320	490
	2.3	1186	0.58	1200	10320	490
	1.9	1065	0.44	1500	10320	490
	1.6	1005	0.36	1800	10320	490
	1.2	1185	0.33	2400	10320	490
	0.9	1100	0.26	3000	10320	490
	0.7	1100	0.21	4000	10320	490
	0.6	1100	0.18	5000	10320	490
VS 063/130						
	28.0	825	3.27	100	10722	471
	18.7	1163	3.27	150	12274	471
	14.0	1531	3.27	200	13500	471
	11.2	1530	2.69	250	13500	471
	9.3	1760	2.84	300	13500	471
	7.0	1650	2.09	400	13500	471
	5.6	1550	1.65	500	13500	471
	4.7	1760	1.49	600	13500	556
	3.7	1760	1.22	750	13500	613
	3.1	1760	1.07	900	13500	700
	2.3	1760	0.83	1200	13500	700
	1.9	1760	0.70	1500	13500	700
	1.6	1760	0.61	1800	13500	700
	1.2	1650	0.45	2400	13500	700
	0.9	1550	0.35	3000	13500	700
	0.7	1550	0.28	4000	13500	700
	0.6	1550	0.25	5000	13500	700
VS 063/150						
	18.7	1444	4.03	150	18000	395
	14.0	1531	3.27	200	18000	471
	11.2	1864	3.27	250	18000	471
	9.3	1678	2.45	300	18000	516
	7.0	2624	3.27	400	18000	471
	5.6	2330	2.48	500	18000	471
	4.7	2670	2.27	600	18000	516
	3.7	2330	1.69	750	18000	516
	3.1	2100	1.19	900	18000	700
	2.3	2670	1.25	1200	18000	700
	1.6	2100	0.68	1800	18000	700
	1.2	2610	0.70	2400	18000	700
	0.9	2330	0.53	3000	18000	700
	0.7	2330	0.43	4000	18000	700
	0.6	2330	0.37	5000	18000	700

Tabella dati tecnici motoriduttori / Table technical data gearmotors

 Pn_1 (kW)	 n_2 (min ⁻¹)	 M_2 (Nm)	fs	i				FR_2 (N)
0.06								
M1 056 0.06 4P... (n1 = 1400 min ⁻¹)	280	2	6.2	5	VP025			439
	280	2	10.1	5	VP030			597
	186.7	3	4.2	7.5	VP025			503
	186.7	3	6.9	7.5	VP030			683
	140	3	3.5	10	VP025			553
	140	3	5.4	10	VP030			752
	93.3	5	2.5	15	VP025			633
	93.3	5	3.8	15	VP030			861
	70	6	2	20	VP025			697
	70	6	3	20	VP030			948
	56	7	3	25	VP030			1021
	46.7	8	1.6	30	VP025			798
	46.7	8	2.5	30	VP030			1085
	35	10	1.3	40	VP025			878
	35	10	1.9	40	VP030			1194
	28	12*	0.9*	50	VP025			946
	28	11	1.5	50	VP030			1286
	28	13	3.3	50	VP040			2475
	23.3	14*	0.7*	60	VP025			1006
	23.3	13	1.3	60	VP030			1367
	23.3	14	2.6	60	VP040			2630
	17.5	14*	0.9*	80	VP030			1504
	17.5	17	1.9	80	VP040			2895
	14	25	1.3	100			VC025/030	1620
	14	20	1.5	100	VP040			3118
	14	26	2.7	100			VC030/040	2769
	9.3	32*	0.9*	150			VC025/030	1830
	9.3	37	1.9	150			VC030/040	3169
	7	41*	0.7*	200			VC025/030	1830
	7	47	1.4	200			VC030/040	3488
	7	47	2.6	200			VC030/050	4788
	5.6	44*	0.8*	250			VC025/030	1830
	5.6	55	1.1	250			VC030/040	3490
	5.6	55	2	250			VC030/050	4840
	4.7	59	1.2	300			VC025/040	3490
	4.7	57	1.3	300			VC030/040	3490
	4.7	61	2.4	300			VC030/050	4840
	3.5	71*	0.9*	400			VC025/040	3490
	3.5	70*	0.9*	400			VC030/040	3490
	3.5	73	1.7	400			VC030/050	4840
	3.5	76	3.4	400			VC030/063	6270
	2.8	96*	0.6*	500			VC030/040	3490
	2.8	82*	0.7*	500			VC025/040	3490
	2.8	85	1.4	500			VC030/050	4840
	2.8	88	2.7	500			VC030/063	6270
	2.3	101*	0.6*	600			VC025/040	3490
	2.3	104*	0.7*	600			VC030/040	3490
	2.3	109	1.3	600			VC030/050	4840
	2.3	111	2.4	600			VC030/063	6270
	1.9	116*	0.5*	750			VC025/040	3490
	1.9	121*	0.6*	750			VC030/040	3490
	1.9	127	1.1	750			VC030/050	4840
	1.9	129	2.1	750			VC030/063	6270
	1.6	143*	0.5*	900			VC025/040	3490
	1.6	139*	0.5*	900			VC030/040	3490
	1.6	141	1	900			VC030/050	4840
	1.6	148	1.8	900			VC030/063	6270
	1.2	171*	0.4*	1200			VC025/040	3490
	1.2	166*	0.4*	1200			VC030/040	3490
	1.2	169*	0.7*	1200			VC030/050	4840
	1.2	180	1.5	1200			VC030/063	6270
	0.93	199*	0.7*	1500			VC030/050	4840
	0.9	197*	0.3*	1500			VC025/040	3490
	0.9	196*	0.4*	1500			VC030/040	3490
	0.9	204	1.1	1500			VC030/063	6270

* **NOTA:** la coppia massima utilizzabile M_{m2} deve essere determinata utilizzando il fattore di servizio fs : $M_{m2} = M_2 \times fs$

* **NOTE:** Maximun allowable torque M_{m2} must be calculated using service factor fs : $M_{m2} = M_2 \times fs$

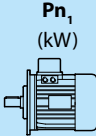
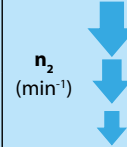
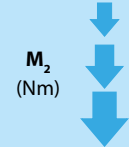
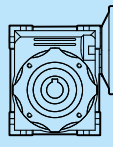
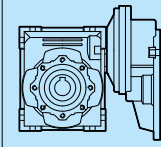
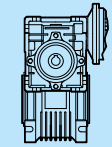
Tabella dati tecnici motoriduttori / Table technical data gearmotors

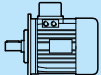
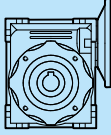
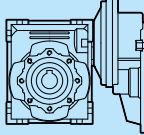
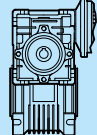
 P_{n1} (kW)	n_2 (min ⁻¹)	M_2 (Nm)	f_s	i				FR_2 (N)
0.06								
M1 056 0.06 4P... ($n_1 = 1400 \text{ min}^{-1}$)	0.9	248	1.8	1500			VC040/075	7380
	0.9	259	2.7	1500			VC040/090	8180
	0.8	217*	0.3*	1800			VC025/040	3490
	0.8	218*	0.3*	1800			VC030/040	3490
	0.8	278	1.6	1800			VC040/075	7380
	0.8	291	2.4	1800			VC040/090	8180
	0.78	222*	0.7*	1800			VC030/050	4840
	0.78	225*	0.9*	1800			VC030/063	6270
	0.6	268*	0.2*	2400			VC025/040	3490
	0.6	266*	0.5*	2400			VC030/050	4840
	0.6	330	1.1	2400			VC040/075	7380
	0.6	359	1.7	2400			VC040/090	8180
	0.58	261*	0.2*	2400			VC030/040	3490
	0.58	276*	0.8*	2400			VC030/063	6270
	0.5	324*	0.2*	3000			VC025/040	3490
	0.5	307*	0.4*	3000			VC030/050	4840
	0.5	406	1.4	3000			VC040/090	8180
	0.47	319*	0.7*	3000			VC030/063	6270
	0.47	377*	0.8*	3000			VC040/075	7380
	0.4	294*	0.1*	4000			VC025/040	3490
	0.4	279*	0.1*	4000			VC030/040	3490
	0.4	300*	0.2*	3200			VC030/040	3490
	0.35	288*	0.3*	4000			VC030/050	4840
	0.35	306*	0.6*	4000			VC030/063	6270
	0.35	355*	0.7*	4000			VC040/075	7380
	0.35	365	1.3	4000			VC040/090	8180
	0.3	356*	0.1*	5000			VC025/040	3490
	0.29	311*	0.3*	4800			VC030/050	4840
	0.28	338*	0.1*	5000			VC030/040	3490
	0.28	360*	0.4*	5000			VC030/063	6270
	0.28	419*	0.5*	5000			VC040/075	7380
	0.28	431	1	5000			VC040/090	8180
0.09								
M1 056 0.09 2P.. ($n_1 = 2800 \text{ min}^{-1}$)	373.3	2	3.9	7.5	VP025			399
	373.3	2	6.5	7.5	VP030			542
	280	2.6	3.4	10	VP025			439
	280	2.6	5	10	VP030			597
	186.7	3.8	2.4	15	VP025			503
	186.7	3.7	3.5	15	VP030			683
	140	4.9	1.8	20	VP025			553
	140	4.7	2.5	20	VP030			752
	112	5.9	1.5	25	VP025			590
	112	5.5	2.9	25	VP030			810
	93.3	6.4	2.3	30	VP030			861
	93.3	6.7	13	30	VP025			633
	70	8.5	1.1	40	VP025			697
	70	8	18	40	VP030			948
	56	10*	0.9*	50	VP025			751
	56	9.4	1.4	50	VP030			1021
	56	11	2.8	50	VP040			1964
	46.7	11*	0.7*	60	VP025			798
	46.7	10	1.1	60	VP030			1085
	46.7	12	2.3	60	VP040			2087
	35	13*	0.9*	80	VP030			1194
	35	15	1.7	80	VP040			2298
	28	17	1.4	100	VP040			2475
	28	18	1.6	100			VC025/030	1286
	18.7	25	1.1	150			VC025/030	1472
	14	31*	0.9*	200			VC025/030	1620
	14	39	1.8	100			VC025/040	2769
	9.3	54	1.2	150			VC025/040	3488
	9.3	43	1.6	300			VC025/040	3490
	7	70*	0.9*	200			VC025/040	3488
	7	52	1.2	400			VC025/040	3490
	5.6	83*	0.7*	250			VC025/040	3490
	5.6	71*	0.8*	500			VC025/040	3490

* **NOTA:** la coppia massima utilizzabile M_{m2} deve essere determinata utilizzando il fattore di servizio f_s : $M_{m2} = M_2 \times f_s$

* **NOTE:** Maximun allowable torque M_{m2} must be calculated using service factor f_s : $M_{m2} = M_2 \times f_s$

Tabella dati tecnici motoriduttori / Table technical data gearmotors

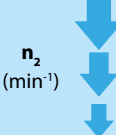
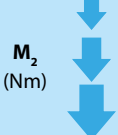
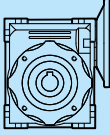
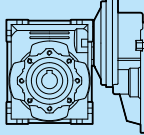
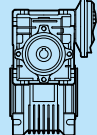
 Pn_1 (kW)	 n_2 (min ⁻¹)	 M_2 (Nm)	fs	i				FR_2 (N)
0.09								
M1 056 0.09 4P. ($n_1 = 1400 \text{ min}^{-1}$)	280	3	4.1	5	VP025			439
	280	3	6.7	5	VP030			597
	186.7	4	2.8	7.5	VP025			503
	186.7	4	4.6	7.5	VP030			683
	140	5	2.4	10	VP025			553
	140	5	3.6	10	VP030			752
	93.3	7	1.6	15	VP025			633
	93.3	7	2.5	15	VP030			861
	70	9	1.3	20	VP025			697
	70	9	2	20	VP030			948
	56	10	2	25	VP030			1021
	46.7	12	1.1	30	VP025			798
	46.7	12	1.7	30	VP030			1085
	35	15*	0.9*	40	VP025			878
	35	14	1.2	40	VP030			1194
	28	17	1	50	VP030			1286
	28	19	2	50	VP040			2475
	23.3	19*	0.9*	60	VP030			1367
	23.3	21	1.7	60	VP040			2630
	17.5	26	1.3	80	VP040			2895
	14	38	0.8	100			VC025/030	1620
	14	29	1	100	VP040			3118
	14	39	1.8	100			VC030/040	2769
	14	40	3.4	100			VC030/050	3800
	9.3	49*	0.6*	150			VC025/030	1830
	9.3	56	1.3	150			VC030/040	3169
	9.3	56	2.4	150			VC030/050	4350
	7	62*	0.5*	200			VC025/030	1830
	7	70*	0.9*	200			VC030/040	3488
	7	70	1.7	200			VC030/050	4788
	5.6	66*	0.5*	250			VC025/030	1830
	5.6	83*	0.7*	250			VC030/040	3490
	5.6	83	1.3	250			VC030/050	4840
	5.6	85	2.7	250			VC030/063	6270
	4.7	75*	0.4*	300			VC025/030	1830
	4.7	88*	0.8*	300			VC030/040	3490
	4.7	92	1.6	300			VC030/050	4840
	4.7	88	2.9	300			VC030/063	6270
	3.5	107*	0.3*	400			VC025/030	1830
	3.5	107	1.2	400			VC030/050	4840
	3.5	114	2.2	400			VC030/063	6270
	2.8	115*	0.3*	500			VC025/030	1830
2.8	123	1	500			VC030/050	4840	
2.8	132	1.8	500			VC030/063	6270	
2.3	135*	0.2*	600			VC025/030	1830	
2.3	159*	0.9*	600			VC030/050	4840	
2.3	166	1.6	600			VC030/063	6270	
1.9	151*	0.2*	750			VC025/030	1830	
1.9	185*	0.8*	750			VC030/050	4840	
1.9	194	1.4	750			VC030/063	6270	
1.6	178*	0.2*	900			VC025/030	1830	
1.6	212*	0.7*	900			VC030/050	4840	
1.6	200	1	900			VC030/063	6270	
1.2	212*	0.1*	1200			VC025/030	1830	
1.2	263*	0.9*	1200			VC030/063	6270	
0.93	305*	0.7*	1500			VC030/063	6270	
0.9	247*	0.1*	1500			VC025/030	1830	
0.9	360	1.1	1500			VC040/075	7380	
0.78	304*	0.1*	1800			VC025/030	1830	
0.78	404	1	1800			VC040/075	7380	
0.58	340*	0.1*	2400			VC025/030	1830	
0.58	496*	0.7*	2400			VC040/075	7380	
0.5	609*	0.9*	3000			VC040/090	8180	
0.47	405*	0.1*	3000			VC025/030	1830	
0.35	548*	0.8*	4000			VC040/090	8180	

* **NOTA:** la coppia massima utilizzabile M_{m2} deve essere determinata utilizzando il fattore di servizio fs : $M_{m2} = M_2 \times fs$

* **NOTE:** Maximun allowable torque M_{m2} must be calculated using service factor fs : $M_{m2} = M_2 \times fs$

Tabella dati tecnici motoriduttori / Table technical data gearmotors

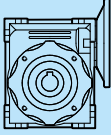
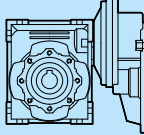
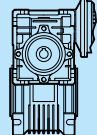
 Pn_1 (kW)	n_2 (min^{-1})	M_2 (Nm)	fs	i				FR_2 (N)
0.12								
M1 056 0.12 2P... ($n_1 = 2800 min^{-1}$)	373.3	2.7	3	7.5	VP025			399
	280	3.5	2.6	10	VP025			439
	186.7	5.1	1.8	15	VP025			503
	186.7	5	2.6	15	VP030			683
	140	6.5	1.4	20	VP025			553
	140	6	1.9	20	VP030			752
	112	7.9	1.1	25	VP025			590
	112	8	2.1	25	VP030			810
	93.3	9	1	30	VP025			633
	93.3	9	1.7	30	VP030			861
	70	11*	0.8*	40	VP025			697
	70	11	1.3	40	VP030			948
	56	13	1	50	VP030			1021
	56	14	2.1	50	VP040			1964
	46.7	14*	0.8*	60	VP030			1085
	46.7	16	1.7	60	VP040			2087
	35	20	1.3	80	VP040			2298
	28	23	1	100	VP040			2475
M1 063 0.12 4P.. ($n_1 = 1400 min^{-1}$)	4.7	117	2.2	300			VC030/063	6270
	4.7	134	3.3	300			VC040/075	7380
	280	4	5.1	5	VP030			597
	186.7	5	3.4	7.5	VP030			683
	140	7	2.7	10	VP030			752
	93.3	10	1.9	15	VP030			861
	70	12	1.5	20	VP030			948
	70	13	3.3	20	VP040			1824
	56	14	1.5	25	VP030			1021
	56	16	2.5	25	VP040			1964
	46.7	16	1.3	30	VP030			1085
	46.7	17	2.6	30	VP040			2087
	35	19*	0.9*	40	VP030			1194
	35	21	1.9	40	VP040			2298
	28	23*	0.8*	50	VP030			1286
	28	25	1.5	50	VP040			2475
	28	26	2.9	50	VP050			3397
	23.3	28	1.3	60	VP040			2630
	23.3	29	2.3	60	VP050			3610
	19.1	42	1.2	73.3			VR063/040	2833
	17.5	34	1	80	VP040			2895
	17.5	35	1.9	80	VP050			3973
	15.9	46	1.2	88			VR063/040	3011
	14	38*	0.8*	100	VP040			3118
	14	52	1.4	100				2769
	14	40	1.4	100	VP050			4280
	14	54	2.6	100			VC030/050	3800
	14	54	2.8	100			VC030/063	4967
	11.9	57*	0.9*	117.3			VR063/040	3314
	11.7	58	1.8	117.2			VR063/050	4548
	9.5	66*	0.7*	146.7			VR063/040	3490
	9.5	68	1.3	146.7			VR063/050	4840
	9.3	74	1	150			VC030/040	3169
	9.3	74	1.8	150			VC030/050	4350
	9.3	75	2.8	150			VC030/063	5686
	8	75	1.1	176			VR063/050	4840
	7.9	74*	0.6*	176			VR063/040	3490
	7	94	1.3	200			VC030/050	4788
	7	95	2.7	200			VC030/063	6259
	6	92	1.5	234.6			VR063/063	6270
5.8	88*	0.8*	234.6			VR063/050	4840	
5.6	110	1	250			VC030/050	4840	
5.6	114	2	250			VC030/063	6270	
5.6	120	3.2	250			VC040/075	7380	

* **NOTA:** la coppia massima utilizzabile M_{m2} deve essere determinata utilizzando il fattore di servizio fs : $M_{m2} = M_2 \times fs$

* **NOTE:** Maximun allowable torque M_{m2} must be calculated using service factor fs : $M_{m2} = M_2 \times fs$

Tabella dati tecnici motoriduttori / Table technical data gearmotors

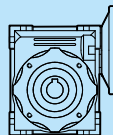
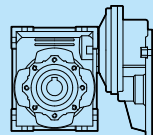
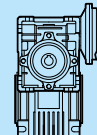
 Pn_1 (kW)	n_2 (min ⁻¹)	M_2 (Nm)	fs	i				FR_2 (N)
0.12								
M1 063 0.12 4P. ($n_1 = 1400 \text{ min}^{-1}$)	4.8	98*	0.7*	293.3		VR063/050		4840
	4.8	103	1.2	293.3		VR063/063		6270
	4.7	119	1.2	300			VC030/050	4840
	3.5	142*	0.9*	400			VC030/050	4840
	3.5	152	1.7	400			VC030/063	6270
	3.5	164	2.5	400			VC040/075	7380
	2.8	164*	0.7*	500			VC030/050	4840
	2.8	171	1.3	500			VC030/063	6270
	2.8	188	2	500			VC040/075	7380
	2.8	202	2.8	500			VC040/090	8180
	2.3	208	1.1	600			VC030/063	6270
	2.3	248	1.8	600			VC040/075	7380
	2.3	260	2.7	600			VC040/090	8180
	1.9	241*	0.9*	750			VC030/063	6270
	1.9	299	1.5	750			VC040/075	7380
	1.9	313	2.2	750			VC040/090	8180
	1.6	297*	0.9*	900			VC030/063	6270
	1.6	325	1.2	900			VC040/075	7380
	1.6	350	2	900			VC040/090	8180
	1.2	360*	0.8*	1200			VC030/063	6270
	1.2	399*	0.9*	1200			VC040/075	7380
	1.2	434	1.6	1200			VC040/090	8180
	1.2	448	2.8	1200			VC050/110	10320
	0.9	495*	0.9*	1500			VC040/075	7380
	0.9	518	1.4	1500			VC040/090	8180
	0.9	527	2.4	1500			VC050/110	10320
	0.8	556*	0.8*	1800			VC040/075	7380
	0.8	547*	0.9*	1800			VC040/090	8180
	0.8	592	2.1	1800			VC050/110	10320
	0.6	766	1.5	2400			VC050/110	10320
0.58	695*	0.9*	2400			VC040/090	8180	
0.5	884	1.2	3000			VC050/110	10320	
0.35	784	1	4000			VC050/110	10320	
0.28	928*	0.8*	5000			VC050/110	10320	
M1 063 0.12 6P. ($n_1 = 900 \text{ min}^{-1}$)	12.3	62	1	73.3		VR063/040		3283
	10.2	68	1.1	88		VR063/040		3488
	7.7	83*	0.8*	117.3		VR063/040		3490
	180	5	3.7	5	VP030			692
	120	8	2.5	7.5	VP030			792
	90	10	2	10	VP030			871
	60	14	1.4	15	VP030			997
	60	15	3.3	15	VP040			1920
	45	18	1.1	20	VP030			1098
	45	19	2.5	20	VP040			2113
	36	20	1.1	25	VP030			1183
	36	23	1.9	25	VP040			2276
	30	23*	0.9*	30	VP030			1257
	30	25	1.9	30	VP040			2419
	22.5	29*	0.7*	40	VP030			1383
	22.5	32	1.4	40	VP040			2662
	22.5	32	2.6	40	VP050			3654
	18	36	1.2	50	VP040			2868
	18	38	2	50	VP050			3936
	15	41*	0.9*	60	VP040			3047
	15	42	1.7	60	VP050			4183
	12.3	63	1.7	73.3		VR063/050		4506
	11.3	50*	0.7*	80	VP040			3354
	11.3	50	1.4	80	VP050			4604
	10.2	70	2.1	88		VR063/050		4788
	9	56	1	100	VP050			4840
	7.7	84	1.5	117.3		VR063/050		4840

* **NOTA:** la coppia massima utilizzabile M_{m2} deve essere determinata utilizzando il fattore di servizio fs : $M_{m2} = M_2 \times fs$

* **NOTE:** Maximun allowable torque M_{m2} must be calculated using service factor fs : $M_{m2} = M_2 \times fs$

Tabella dati tecnici motoriduttori / Table technical data gearmotors

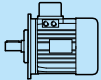
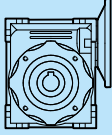
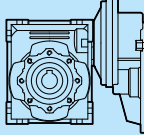
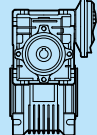
 P_{n1} (kW)	n_2 (min ⁻¹)	M_2 (Nm)	f_s	i				FR_2 (N)
0.12								
M1 063 0.12 6P.. (n1 = 900 min ⁻¹)	6.1	97	1.2	146.7		VR063/050		4840
	6.1	101	2.1	146.7		VR063/063		6270
	5.1	108	1	176		VR063/050		4840
	5.1	112	1.8	176		VR063/063		6270
	3.8	125*	0.7*	234.6		VR063/050		4840
	3.8	131	1.3	234.6		VR063/063		6270
	3.1	145	1	293.3		VR063/063		6270
0.18								
M1 063 0.18 2P.. (n1 = 2800 min ⁻¹)	373.3	4	3.2	7.5	VP030			542
	280	5.2	2.5	10	VP030			597
	186.7	7.4	1.8	15	VP030			683
	140	9.5	1.3	20	VP030			752
	140	10	2.8	20	VP040			1447
	112	11	1.4	25	VP030			810
	112	12	2.3	25	VP040			1559
	93.3	13	1.2	30	VP030			861
	93.3	14	2.5	30	VP040			1657
	70	16*	0.9*	40	VP030			948
	70	17	1.8	40	VP040			1824
	70	18	3.2	40	VP050			2503
	56	21	1.4	50	VP040			1964
	56	21	2.5	50	VP050			2696
	46.7	24	1.2	60	VP040			2087
	46.7	24	2.1	60	VP050			2865
	35	29*	0.8*	80	VP040			2298
	35	30	1.5	80	VP050			3153
	28	34	1.2	100	VP050			3397
	M1 063 0.18 4P.. (n1 = 1400 min ⁻¹)	280	5	3.4	5	VP030		
186.7		8	2.3	7.5	VP030			683
140		10	1.8	10	VP030			752
93.3		14	1.3	15	VP030			861
93.3		15	2.9	15	VP040			1657
70		18	1	20	VP030			948
70		19	2	20	VP040			1824
56		21	1	25	VP030			1021
56		23	1.7	25	VP040			1964
46.7		24*	0.8*	30	VP030			1085
46.7		26	1.7	30	VP040			2087
35		32	1.3	40	VP040			2298
35		33	2.3	40	VP050			3153
28		38	1	50	VP040			2475
28		39	1.9	50	VP050			3397
23.3		43*	0.8*	60	VP040			2630
23.3		43	1.6	60	VP050			3610
19.1		64*	0.8*	73.3		VR063/040		2833
17.5		52	1.2	80	VP050			3973
15.9		70*	0.8*	88		VR063/040		3011
14		78*	0.9*	100			VC030/040	2769
14		60*	0.9*	100	VP050			4280
14		81	1.7	100			VC030/050	3800
14		81	1.9	100			VC030/063	4967
11.9		85*	0.6*	117.3		VR063/040		3314
11.9		87	1.1	117.3		VR063/050		4548
9.5		101*	0.9*	146.7		VR063/050		4840
9.3		112	1.2	150			VC030/050	4350
9.3		113	1.9	150			VC030/063	5686
7.9		113*	0.7*	176		VR063/050		4840
7		141*	0.9*	200			VC030/050	4788
7		143	1.8	200			VC030/063	6259
7		150	2.8	200			VC040/075	7380
5.8	133*	0.6*	234.6		VR063/050		4840	

* **NOTA:** la coppia massima utilizzabile M_{m2} deve essere determinata utilizzando il fattore di servizio f_s : $M_{m2} = M_2 \times f_s$

* **NOTE:** Maximun allowable torque M_{m2} must be calculated using service factor f_s : $M_{m2} = M_2 \times f_s$

Tabella dati tecnici motoriduttori / Table technical data gearmotors

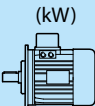
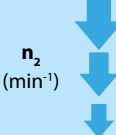
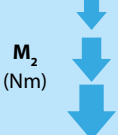
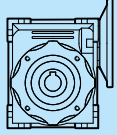
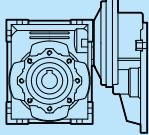
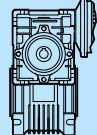
 Pn_1 (kW)	 n_2 (min ⁻¹)	 M_2 (Nm)	fs	i				FR_2 (N)
0.18								
M1 063 0.18 4P. (n1 = 1400 min ⁻¹)	5.6	171	1.4	250			VC030/063	6270
	5.6	180	2.1	250			VC040/075	7380
	5.6	188	3	250			VC040/090	8180
	4.7	183*	0.8*	300			VC030/050	4840
	4.7	175	1.5	300			VC030/063	6270
	4.7	200	2.2	300			VC040/075	7380
	4.7	210	3.3	300			VC040/090	8180
	3.5	222	1	400			VC030/063	6270
	3.5	246	1.7	400			VC040/075	7380
	3.5	259	2.4	400			VC040/090	8180
	2.8	257*	0.8*	500			VC030/063	6270
	2.8	282	1.3	500			VC040/075	7380
	2.8	303	1.9	500			VC040/090	8180
	2.3	333*	0.8*	600			VC030/063	6270
	2.3	362	1.1	600			VC040/075	7380
	2.3	390	1.8	600			VC040/090	8180
	1.9	435*	0.9*	750			VC040/075	7380
	1.9	469	1.5	750			VC040/090	8180
	1.6	487*	0.8*	900			VC040/075	7380
	1.6	526	1.3	900			VC040/090	8180
1.2	622*	0.7*	1200			VC040/075	7380	
1.2	629	1	1200			VC040/090	8180	
1.2	671	1.9	1200			VC050/110	10320	
0.9	735*	0.8*	1500			VC040/090	8180	
0.9	790	1.6	1500			VC050/110	10320	
0.8	874*	0.8*	1800			VC040/090	8180	
0.8	861	1.5	1800			VC050/110	10320	
0.58	1113	1.1	2400			VC050/110	10320	
0.5	1370*	0.8*	3000			VC050/110	10320	
M1 071 0.18 6P. (n1 = 900 min ⁻¹)	90	16	3	10	VP040			1677
	60	23	2.2	15	VP040			1920
	45	29	1.5	20	VP040			2113
	45	29	2.8	20	VP050			2900
	36	34	1.3	25	VP040			2276
	36	35	2.1	25	VP050			3124
	30	38	1.3	30	VP040			2419
	30	40	2.4	30	VP050			3320
	22.5	47	1	40	VP040			2662
	22.5	49	1.8	40	VP050			3654
	22.5	50	3.4	40	VP063			4776
	18	56	1.4	50	VP050			3936
	18	59	2.7	50	VP063			5145
	15	63	1.1	60	VP050			4183
	15	66	2.1	60	VP063			5467
	15	66	2.1	60	VP075			5467
	12.2	95	1.2	73.5		VR071/050		4506
	11.3	75*	0.9*	80	VP050			4604
	11.3	79	1.6	80	VP063			6018
	11.3	79	1.6	80	VP075			6018
	10.2	105	1.4	88.2		VR071/050		4788
	9	90	1.4	100	VP063			6270
	9	90	1.4	100	VP075			6270
	7.7	126	1	117.6		VR071/050		4840
	7.7	131	1.8	117.6		VR071/063		6270
	6.1	152	1.4	147		VR071/063		6270
	6	148*	0.8*	147		VR071/050		
	5.1	168	1.2	176.4		VR071/063		6270
	5.1	179	1.7	176.4		VR071/075		7380
	3.8	197*	0.9*	235.2		VR071/063		6270
	3.8	211	1.2	235.2		VR071/075		7380
	3.1	218*	0.7*	294		VR071/063		6270
3.1	235	1	294		VR071/075		7380	

* **NOTA:** la coppia massima utilizzabile M_{m2} deve essere determinata utilizzando il fattore di servizio fs : $M_{m2} = M_2 \times fs$

* **NOTE:** Maximun allowable torque M_{m2} must be calculated using service factor fs : $M_{m2} = M_2 \times fs$

Tabella dati tecnici motoriduttori / Table technical data gearmotors

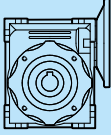
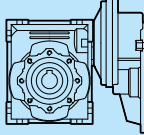
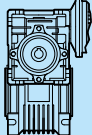
 Pn_1 (kW)	n_2 (min^{-1})	M_2 (Nm)	fs	i				FR_2 (N)
0.25								
M1 063 0.25 2P. ($n_1 = 2800 min^{-1}$)	373.3	5.6	2.3	7.5	VP030			542
	280	7.2	1.8	10	VP030			597
	186.7	10	1.3	15	VP030			683
	186.7	11	2.9	15	VP040			1315
	140	13*	0.9*	20	VP030			752
	140	14	2	20	VP040			1447
	112	15	1	25	VP030			810
	112	17	1.6	25	VP040			1559
	93.3	18*	0.8*	30	VP030			861
	93.3	20	1.7	30	VP040			1657
	70	25	1.2	40	VP040			1824
	70	25	2.3	40	VP040			2503
	56	29	1	50	VP040			1964
	56	30	1.8	50	VP040			2696
	46.7	34*	0.8*	60	VP040			2087
	46.7	34	1.5	60	VP040			2865
	35	42	1.1	80	VP040			3153
	28	48*	0.8*	100	VP040			3397
	7	150	1.4	400			VC030/063	6270
	5.6	175	1.2	500			VC030/063	6270
M1 071 0.25 4P. ($n_1 = 1400 min^{-1}$)	280	8	4.5	5	VP040			1149
	186.7	11	3.6	7.5	VP040			1315
	140	14	2.8	10	VP040			1447
	93.3	21	1.9	15	VP040			1657
	70	27	1.5	20	VP040			1824
	70	27	2.7	20	VP050			2503
	56	32	1.2	25	VP040			1964
	56	32	2.2	25	VP050			2696
	46.7	36	1.3	30	VP040			2087
	46.7	37	2.3	30	VP050			2865
	35	44*	0.9*	40	VP040			2298
	35	46	1.7	40	VP050			3153
	35	48	3.1	40	VP063			4122
	28	54	1.4	50	VP050			3397
	28	56	2.4	50	VP063			4440
	23.3	60	1.1	60	VP050			3610
	23.3	63	2	60	VP063			4719
	23.3	68	3.2	60	VP075			5569
	19	88	1	73.5		VR071/050		3889
	17.5	72*	0.9*	80	VP050			3973
	17.5	78	1.6	80	VP063			5193
	17.5	82	2.3	80	VP075			6130
	15.9	98	1.1	88.2		VR071/050		4132
	14	87	1.4	100	VP063			5595
	14	94	1.9	100	VP075			6603
	14	116	3	100			VC040/075	5863
	14	119	3	100			VC040/090	6487
	11.9	121*	0.8*	117.6		VR071/050		4548
	11.9	125	1.5	117.6		VR071/063		5945
	9.5	143	1.2	147		VR071/063		6270
	9.5	151	1.7	147		VR071/075		7380
	7.9	163	1	176.4		VR071/063		6270
	7.9	172	1.4	176.4		VR071/075		7380
	7	209	2	200			VC040/075	7380
	7	217	2.8	200			VC040/090	8174
	6	192*	0.7*	235.2		VR071/063		6270
6	201	1.1	235.2		VR071/075		7380	
5.6	250	1.5	250			VC040/075	7380	
5.6	261	2.2	250			VC040/090	8180	
4.8	215*	0.6*	294		VR071/063		6270	
4.8	230*	0.9*	294		VR071/075		7380	
4.7	278	1.6	300			VC040/075	7380	

* **NOTA:** la coppia massima utilizzabile M_{m2} deve essere determinata utilizzando il fattore di servizio fs : $M_{m2} = M_2 \times fs$

* **NOTE:** Maximun allowable torque M_{m2} must be calculated using service factor fs : $M_{m2} = M_2 \times fs$

Tabella dati tecnici motoriduttori / Table technical data gearmotors

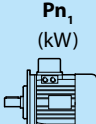
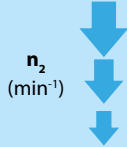
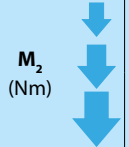
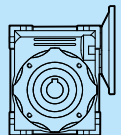
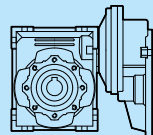
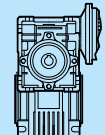
 P_{n1} (kW)	 n_2 (min ⁻¹)	 M_2 (Nm)	f_s	i				FR_2 (N)
0.25								
M1 071 0.25 4P. (n1 = 1400 min ⁻¹)	4.7	291	2.4	300			VC040/090	8180
	3.5	336	1.1	400			VC040/075	7380
	3.5	359	1.7	400			VC040/090	8180
	3.5	386	3.1	400			VC050/110	10320
	2.8	384*	0.8*	500			VC040/075	7380
	2.8	420	1.3	500			VC040/090	8180
	2.8	512	2.3	500			VC050/110	10320
	2.8	460	3.4	500			VC063/130	13500
	2.3	517*	0.9*	600			VC040/075	7380
	2.3	512	1.2	600			VC040/090	8180
	2.3	548	2.3	600			VC050/110	10320
	2.3	571	3.1	600			VC063/130	13500
	1.9	622*	0.7*	750			VC040/075	7380
	1.9	598*	0.9*	750			VC040/090	8180
	1.9	660	1.9	750			VC050/110	10320
	1.9	687	2.6	750			VC063/130	13500
	1.9	666	3.5	750			VC063/150	18000
	1.6	667*	0.8*	900			VC040/090	8180
	1.6	751	1.7	900			VC050/110	10320
	1.6	783	2.2	900			VC063/130	13500
	1.6	840	2.5	900			VC063/150	18000
	1.2	905*	0.8*	1200			VC040/090	8180
	1.2	943	1.3	1200			VC050/110	10320
	1.2	988	1.8	1200			VC063/130	13500
	1.2	1013	2.6	1200			VC063/150	18000
	0.93	1064	1.2	1500			VC050/110	10320
	0.9	1165	1.5	1500			VC063/130	13500
	0.8	1315	1.3	1800			VC063/130	13500
	0.8	1199	1.8	1800			VC063/150	18000
	0.78	1195	1.1	1800			VC050/110	10320
	0.6	1676*	0.7*	2400			VC050/110	10320
	0.6	1624	1	2400			VC063/130	13500
0.6	1446	1.8	2400			VC063/150	18000	
0.5	1713	1.4	3000			VC063/150	18000	
0.47	1935*	0.8*	3000			VC063/130	13500	
0.4	2026*	0.9*	4000			VC063/150	18000	
0.35	2046*	0.6*	4000			VC063/130	13500	
0.3	2251*	0.7*	5000			VC063/150	18000	
0.28	2430*	0.5*	5000			VC063/130	13500	
M1 071 0.25 6P. (n1 = 900 min ⁻¹)	180	12	3.5	5	VP040			1331
	120	17	2.6	7.5	VP040			1524
	90	22	2	10	VP040			1677
	60	31	1.4	15	VP040			1920
	60	32	2.9	15	VP050			2635
	45	40	1.1	20	VP040			2113
	45	40	1.9	20	VP050			2900
	36	48*	0.9*	25	VP040			2276
	36	48	1.5	25	VP050			3124
	36	50	3	25	VP063			4084
	30	53*	0.9*	30	VP040			2419
	30	54	1.7	30	VP050			3320
	30	57	3.1	30	VP063			4339
	22.5	67*	0.7*	40	VP040			2662
	22.5	67	1.2	40	VP050			3654
	22.5	70	2.4	40	VP063			4776
	18	78	1	50	VP050			3936
	18	81	1.8	50	VP063			5145
	18	85	3	50	VP075			6073
	15	88*	0.8*	60	VP050			4183
15	92	1.5	60	VP063			5467	

* **NOTA:** la coppia massima utilizzabile M_{m2} deve essere determinata utilizzando il fattore di servizio f_s : $M_{m2} = M_2 \times f_s$

* **NOTE:** Maximun allowable torque M_{m2} must be calculated using service factor f_s : $M_{m2} = M_2 \times f_s$

Tabella dati tecnici motoriduttori / Table technical data gearmotors

Pn_1 (kW)	n_2 (min ⁻¹)	M_2 (Nm)	fs	i		FR_2 (N)
0.25						
M1 071 0.25 6P. (n1 = 900 min ⁻¹)	15	99	2.5	60	VP075	6453
	11.3	110	1.2	80	VP063	6018
	11.3	117	1.7	80	VP075	7103
	9	125	1	100	VP063	6270
	9	133	1.4	100	VP075	7380
	7.7	181	1.3	117.6		VR071/063
	7.7	191	1.9	117.6		VR071/075
	6.1	211	1	147		VR071/063
	6.1	219	1.5	147		VR071/075
	5.1	248	1.2	176.4		VR071/075
0.37						
M1 071 0.37 2P. (n1 = 2800 min ⁻¹)	373.3	8.3	3.4	7.5	VP040	1044
	280	11	2.6	10	VP040	1149
	186.7	16	1.9	15	VP040	1315
	140	20	1.4	20	VP040	1447
	112	25	1.1	25	VP040	1559
	112	25	2	25	VP050	2140
	93.3	29	1.2	30	VP040	1657
	93.3	29	2.2	30	VP050	2274
	70	37*	0.8*	40	VP040	1824
	70	37	1.6	40	VP050	2503
	70	38	2.9	40	VP063	3272
	56	44	1.2	50	VP050	2696
	56	45	2.3	50	VP063	3524
	56	47	3.5	50	VP075	4160
	46.7	50	1	60	VP050	2865
	46.7	52	1.9	60	VP063	3745
	46.7	55	2.9	60	VP075	4421
	35	62*	0.7*	80	VP050	3153
	35	65	1.4	80	VP063	4122
	35	68	2.1	80	VP075	4865
28	74	1.1	100	VP063	4440	
28	78	1.7	100	VP075	5241	
9.3	182	1.3	300		VC030/063	
7	222	1	400		VC030/063	
M1 071 0.37 4P. (n1 = 1400 min ⁻¹)	4.7	441	2.9	300		VC050/110
	280	11	3	5	VP040	1149
	186.7	16	2.4	7.5	VP040	1315
	140	21	1.9	10	VP040	1447
	140	22	3.3	10	VP050	1987
	93.3	31	1.3	15	VP040	1657
	93.3	31	2.4	15	VP050	2274
	70	39	1	20	VP040	1824
	70	40	1.8	20	VP050	2503
	56	47*	0.8*	25	VP040	1964
	56	48	1.5	25	VP050	2696
	56	50	2.7	25	VP063	3524
	46.7	53*	0.8*	30	VP040	2087
	46.7	55	1.5	30	VP050	2865
	46.7	57	2.8	30	VP063	3745
	35	68	1.1	40	VP050	3153
	35	71	2.1	40	VP063	4122
	35	74	3.3	40	VP075	4865
	28	80*	0.9*	50	VP050	3397
	28	83	1.6	50	VP063	4440
28	88	2.5	50	VP075	5241	
23.3	89*	0.8*	60	VP050	3610	
23.3	94	1.4	60	VP063	4719	
23.3	98	2.0	60	VP075	5569	

* **NOTA:** la coppia massima utilizzabile M_{m2} deve essere determinata utilizzando il fattore di servizio fs : $M_{m2} = M_2 \times fs$

* **NOTE:** Maximun allowable torque M_{m2} must be calculated using service factor fs : $M_{m2} = M_2 \times fs$

Tabella dati tecnici motoriduttori / Table technical data gearmotors

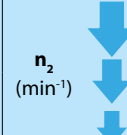
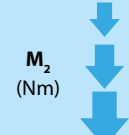
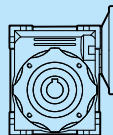
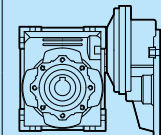
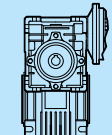
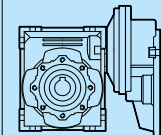
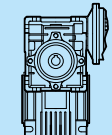
 P_{n1} (kW)	 n_2 (min ⁻¹)	 M_2 (Nm)	f_s	i				FR_2 (N)
0.37								
M1 071 0.37 4P. (n1 = 1400 min ⁻¹)	17.5	115	1.1	80	VP063 VP075 VP063 VP075			5193
	17.5	121	1.6	80				6130
	14	129*	0.9*	100				5595
	14.0	139	1.3	100				6603
	14	172	2.1	100				5863
	14	176	2.1	100				6487
	11.9	185	1	117.6				5945
	9.5	212*	0.8*	147				6270
	9.5	223	1.1	147				7380
	9.3	245	1.7	150				6712
	9.3	251	2.1	150				7426
	7.9	254*	0.9*	176.4				7380
	7	309	1.4	200				7380
	7	322	1.9	200				8174
	7	338	3.4	200				10320
	5.6	370	1	250				7380
	5.6	386	1.5	250				8180
	5.6	412	2.8	250				10320
	4.7	405	1	300				7380
	4.7	402	1.5	300				8180
	3.5	498*	0.7*	400				7380
	3.5	523	1.2	400				8180
	3.5	571	2.1	400				10320
	3.5	571	2.9	400				13500
	2.8	611*	0.9*	500				8180
	2.8	757	1.5	500				10320
	2.8	681	2.3	500				13500
	2.8	681	3.4	500				18000
	2.3	757*	0.8*	600				8180
	2.3	812	1.6	600				10320
	2.3	844	2.1	600				13500
	2.3	840	3.2	600				18000
1.9	950	1.3	750	10320				
1.9	1017	1.7	750	13500				
1.9	986	2.4	750	18000				
1.6	1079	1.2	900	10320				
1.6	1158	1.5	900	13500				
1.6	1244	1.7	900	18000				
1.2	1396*	0.8*	1200	10320				
1.2	1462	1.2	1200	13500				
1.2	1499	1.8	1200	18000				
0.9	1623*	0.8*	1500	10320				
0.9	1674	1.1	1500	13500				
0.8	1887*	0.9*	1800	13500				
0.8	1775	1.2	1800	18000				
0.6	2141	1.2	2400	18000				
0.5	2535*	0.9*	3000	18000				

* **NOTA:** la coppia massima utilizzabile M_{m2} deve essere determinata utilizzando il fattore di servizio f_s : $M_{m2} = M_2 \times f_s$

* **NOTE:** Maximun allowable torque M_{m2} must be calculated using service factor f_s : $M_{m2} = M_2 \times f_s$

Tabella dati tecnici motoriduttori / Table technical data gearmotors

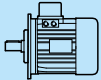
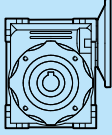
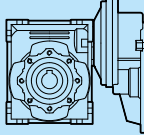
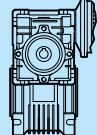
 Pn_1 (kW)	n_2 (min ⁻¹)	M_2 (Nm)	fs	i				FR_2 (N)
0.37								
M1 080 0.37 6P.. (n1 = 900 min ⁻¹)	180	17	4.3	5	VP050			1827
	120	25	3.3	7.5	VP050			2091
	90	33	2.5	10	VP050			2302
	60	47	1.8	15	VP050			2635
	45	60	1.3	20	VP050			2900
	45	60	2.4	20	VP063			3791
	36	72	1	25	VP050			3124
	36	74	1.9	25	VP063			4084
	36	77	3.1	25	VP075			4820
	30	80	1.1	30	VP050			3320
	30	82	2.1	30	VP063			4339
	30	87	3.3	30	VP075			5122
	22.5	102	1.6	40	VP063			4776
	22.5	108	2.6	40	VP075			5637
	18	120	1.2	50	VP063			5145
	18	126	1.8	50	VP075			6073
	18	136	3.2	50	VP090			6719
	15	137	1	60	VP063			5467
	15	144	1.5	60	VP075			6453
	15	153	2.5	60	VP090			7140
	12	206	1.6	75		VR080/075		6952
	11.3	167*	0.8*	80	VP063			6018
	11.3	173	1.2	80	VP075			7103
	11.3	185	1.7	80	VP090			7859
	11.3	201	2.8	80	VP110			9931
	10	260	1.7	90		VR080/075		7380
	9	196	1	100	VP075			7380
	9	212	1.3	100	VP090			8180
9	232	2.2	100	VP110			10320	
7.5	283	1.3	120		VR080/075		7380	
6	324	1	150		VR080/075		7380	
6	347	1.6	150		VR080/090		8180	
5	389	1.3	180		VR080/090		8180	
3.8	471	1.0	240		VR080/090		8180	
3.8	509	1.6	240		VR080/110		10320	
3	577	1.3	300		VR080/110		10320	

* **NOTA:** la coppia massima utilizzabile M_{m2} deve essere determinata utilizzando il fattore di servizio fs : $M_{m2} = M_2 \times fs$

* **NOTE:** Maximun allowable torque M_{m2} must be calculated using service factor fs : $M_{m2} = M_2 \times fs$

Tabella dati tecnici motoriduttori / Table technical data gearmotors

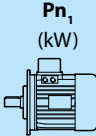
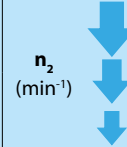
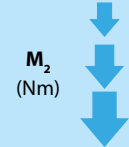
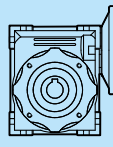
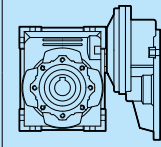
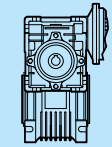
 Pn_1 (kW)	 n_2 (min ⁻¹)	 M_2 (Nm)	fs	i				FR_2 (N)
0.55								
M1 071 0.55 2P. (n1 = 2800 min ⁻¹)	373	12	2.3	7.5	VP040			1044
	280	16	1.8	10	VP040			1149
	280	17	3.2	10	VP050			1577
	187	24	1.3	15	VP040			1315
	186.7	24	2.4	15	VP050			18,5
	140	30	1	20	VP040			1447
	140	31	1.7	20	VP050			1987
	140	32	3.3	20	VP063			2597
	112	37*	0.8*	25	VP040			1559
	112	38	1.4	25	VP050			2140
	112	39	2.5	25	VP063			2797
	93.3	43*	0.8*	30	VP040			1657
	93.3	43	1.5	30	VP050			2274
	93.3	44	2.7	30	VP063			2973
	70	55	1.1	40	VP050			2503
	70	56	1.9	40	VP063			3272
	70	59	3.1	40	VP075			3862
	56	65*	0.8*	50	VP050			2696
	56	68	1.5	50	VP063			3524
	56	70	2.3	50	VP075			4160
	46.7	74*	0.7*	60	VP050			2865
	46.7	78	1.2	60	VP063			3745
	46.7	81	2	60	VP075			4421
	35	96*	0.9*	80	VP063			4122
	35	99	1.3	80	VP075			4865
	28	111*	0.7*	100	VP063			4440
28	116	1	100	VP075			5241	
9.3	305	2	300			VC040/090	8180	
7	375	1.5	400			VC040/090	8180	
5.6	441	1.2	500			VC040/090	8180	
M1 080 0.55 4P. (n1 = 1400 min ⁻¹)	280	17	3.7	5	VP050			1577
	186.7	25	2.9	7.5	VP050			1805
	140	32	2.2	10	VP050			1987
	93.3	46	1.6	15	VP050			2274
	93.3	47	3.2	15	VP063			2973
	70	59	1.2	20	VP050			2503
	70	61	2.2	20	VP063			3272
	56	71	1	25	VP050			2696
	56	73	1.8	25	VP063			3524
	56	76	2.8	25	VP075			4160
	46.7	81	1	30	VP050			2865
	46.7	83	1.9	30	VP063			3745
	46.7	87	2.9	30	VP075			4421
	35	105	1.4	40	VP063			4122
	35	108	2	40	VP075			4865
	35	114	3.5	40	VP090			5383
	28	124	1.1	50	VP063			4440
	28	129	1.6	50	VP075			5241
	28	137	2.7	50	VP090			5799
	23.3	140*	0.9*	60	VP063			4719
	23.3	146	1.4	60	VP075			5569
	23.3	158	2.2	60	VP090			6163
	18.7	205	1.2	75			VR080/075	6000
	17.5	180	1.1	80	VP075			6130
	17.5	189	1.5	80	VP090			6783
	17.5	201	2.6	80	VP110			8571
	15.6	230	1.3	90			VR080/075	6375
	14	206*	0.9*	100	VP075			6603
	14	221	1.2	100	VP090			7306
	14	236	2	100	VP110			9232
	14	268	2.4	100			VC050/110	10320

* **NOTA:** la coppia massima utilizzabile M_{m2} deve essere determinata utilizzando il fattore di servizio fs : $M_{m2} = M_2 \times fs$

* **NOTE:** Maximun allowable torque M_{m2} must be calculated using service factor fs : $M_{m2} = M_2 \times fs$

Tabella dati tecnici motoriduttori / Table technical data gearmotors

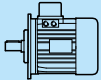
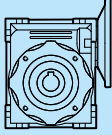
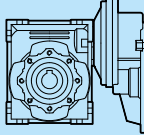
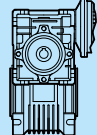
 P_{n1} (kW)	n_2 (min^{-1})	M_2 (Nm)	f_s	i				FR_2 (N)
0.55								
M1 080 0.55 4P. ($n_1 = 1400 \text{ min}^{-1}$)	11.7	284	1	120		VR080/075		7017
	11.7	297	1.6	120		VR080/090		7764
	9.3	332*	0.8*	150		VR080/075		7380
	9.3	355	1.3	150		VR080/090		8180
	9.3	387	2.4	150			VC050/110	10320
	9.3	387	3.1	150			VC063/110	9384
	7.8	398	1	180		VR080/090		8180
	7	503	2.3	200			VC050/110	10320
	7	503	3.2	200			VC063/130	13500
	5.8	513	1.3	240		VR080/110		10320
	5.6	612	1.9	250			VC050/110	10320
	5.6	612	2.5	250			VC063/130	13500
	4.7	597	1	300		VR080/110		10320
	4.7	639	2	300			VC050/110	10320
	4.7	666	2.6	300			VC063/130	13500
	3.5	826	1.4	400			VC050/110	10320
	3.5	849	1.9	400			VC063/130	13500
	2.8	984	1.1	500			VC050/110	10320
	2.8	996	1.6	500			VC063/130	13500
	2.3	1181	1	600			VC050/110	10320
	1.9	1411*	0.9*	750			VC050/110	10320
	1.9	1471	1.2	750			VC063/130	13500
	1.6	1651*	0.8*	900			VC050/110	10320
	1.2	2132*	0.8*	1200			VC063/130	13500
0.8	2638*	0.8*	1800			VC063/150	18000	
0.6	3182*	0.8*	2400			VC063/150	18000	
M1 080 0.55 6P. ($n_1 = 900 \text{ min}^{-1}$)	120	38	2.2	7.5	VP050			2091
	90	49	1.7	10	VP050			2302
	90	50	3.1	10	VP063			3009
	60	69	1.2	15	VP050			2635
	60	71	2.2	15	VP063			3444
	45	89*	0.9*	20	VP050			2900
	45	90	1.6	20	VP063			3791
	45	93	2.9	20	VP075			4474
	36	109	1.3	25	VP063			4084
	36	124	2.1	25	VP075			4820
	36	117	3.5	25	VP090			5333
	30	123	1.4	30	VP063			4339
	30	128	2	30	VP075			5122
	22.5	152	1.1	40	VP063			4776
	22.5	159	1.5	40	VP075			5637
	22.5	168	2.7	40	VP090			6238
	18	181*	0.9*	50	VP063			5145
	18	187	1.2	50	VP075			6073
	18	198	2	50	VP090			6719
	15	207*	0.7*	60	VP063			5467
	15	214	1	60	VP075			6453
	15	224	1.6	60	VP090			7140
	15	242	2.8	60	VP110			9023
	12	306	1.1	75		VR080/075		6952
	11.3	262*	0.8*	80	VP075			7103
	11.3	275	1.1	80	VP090			7859
	11.3	294	1.9	80	VP110			9931
	10	341	1.1	90		VR080/075		7380
	9	315*	0.9*	100	VP090			8180
	9	338	1.5	100	VP110			10320
	7.5	441	1.4	120		VR080/090		8180
	6	516	1.1	150		VR080/090		8180
5	578*	0.9*	180		VR080/090		8180	
3.8	756	1.1	240		VR080/110		10320	

* **NOTA:** la coppia massima utilizzabile M_{m2} deve essere determinata utilizzando il fattore di servizio f_s : $M_{m2} = M_2 \times f_s$

* **NOTE:** Maximun allowable torque M_{m2} must be calculated using service factor f_s : $M_{m2} = M_2 \times f_s$

Tabella dati tecnici motoriduttori / Table technical data gearmotors

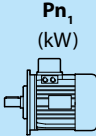
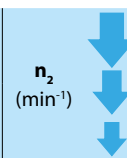
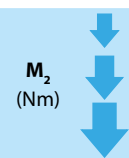
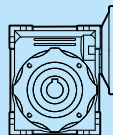
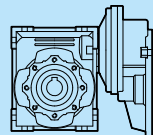
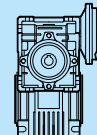
 Pn_1 (kW)	 n_2 (min ⁻¹)	 M_2 (Nm)	fs	i				FR_2 (N)
0.75								
M2 080 0.75 2P. (n1 = 2800 min ⁻¹)	373.3	17	3	7.5	VP050			1433
	280	22	2.4	10	VP050			1577
	186.7	31	1.7	15	VP050			1805
	186.7	33	3.3	15	VP063			2359
	140	41	1.3	20	VP050			1987
	140	43	2.3	20	VP063			2597
	112	49	1	25	VP050			2140
	112	52	1.8	25	VP063			2797
	112	54	2.9	25	VP075			3302
	93.3	56	1.1	30	VP050			2274
	93.3	60	2	30	VP063			2973
	93.3	62	3	30	VP075			3509
	70	77	1.4	40	VP063			3272
	70	80	2.3	40	VP075			3862
	70	82	3.4	40	VP090			4273
	56	92	1.1	50	VP063			3524
	56	96	1.7	50	VP075			4160
	56	99	2.7	50	VP090			4603
	46.7	106*	0.9*	60	VP063			3745
	46.7	107	1.3	60	VP075			4421
	46.7	115	2.1	60	VP090			4891
	35	135	1	80	VP075			4865
	35	143	1.6	80	VP090			5383
	35	152	2.6	80	VP110			6803
	28	159*	0.8*	100	VP075			5241
	28	169	1.2	100	VP090			5799
	28	179	2.1	100	VP110			7328
	9.3	424	2.8	300			VC050/110	10320
	7	512	1.1	400			VC040/090	8180
	7	553	2.1	400			VC050/110	10320
5.6	601*	0.9*	500			VC040/090	8180	
5.6	640	1.6	500			VC050/110	10320	
M2 080 0.75 4P. (n1 = 1400 min ⁻¹)	280	23	2.7	5	VP050			1577
	186.7	34	2.1	7.5	VP050			1805
	140	44	1.6	10	VP050			1987
	140	45	3	10	VP063			2567
	93.3	63	1.2	15	VP050			2274
	93.3	64	2.2	15	VP063			2973
	93	66	3.5	15	VP075			3509
	70	81*	0.9*	20	VP050			2503
	70	83	1.6	20	VP063			3272
	70	85	2.8	20	VP075			3862
	56	99*	0.7*	25	VP050			2696
	56	100	1.3	25	VP063			3524
	56	102	2	25	VP075			4160
	46.7	112*	0.8*	30	VP050			2865
	46.7	114	1.4	30	VP063			3745
	46.7	117	2	30	VP075			4421
	35	143	1	40	VP063			4122
	35	147	1.5	40	VP075			4865
	35.0	156	3	40	VP090			5383
	28	171*	0.8*	50	VP063			4440
	28	177	1.2	50	VP075			5241
	28	184	1.8	50	VP090			5800
	28	194	3.4	50	VP110			7328
	23.3	200	1	60	VP075			5569
	23.3	212	1.5	60	VP090			6163
	23.3	227	2.7	60	VP110			7787
	18.7	280*	0.9*	75			VR080/075	6000
	17.5	258	1.1	80	VP090			6783
	17.5	274	1.9	80	VP110			8571
	17.5	250	80	6130	VP075			6130
15.6	313	1	90			VR080/075	6375	

* **NOTA:** la coppia massima utilizzabile M_{m2} deve essere determinata utilizzando il fattore di servizio fs : $M_{m2} = M_2 \times fs$

* **NOTE:** Maximun allowable torque M_{m2} must be calculated using service factor fs : $M_{m2} = M_2 \times fs$

Tabella dati tecnici motoriduttori / Table technical data gearmotors

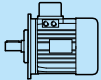
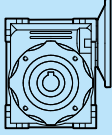
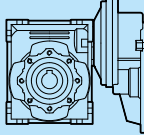
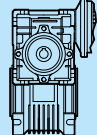
 Pn_1 (kW)	n_2 (min ⁻¹)	M_2 (Nm)	fs	i				FR_2 (N)		
0.75										
M2 080 0.75 4P. (n1 = 1400 min ⁻¹)	14	302*	0.9*	100	VP090 VP110			7306		
	14	322	1.5	100				9232		
	14	365	1.8	100	VR080/090 VR080/090		VC050/110 VC063/130	8198		
	14	369	3	100				10722		
	11.7	405	1.2	120				7764		
	9.3	483*	0.9*	150				8180		
	9.3	527	1.8	150				VC050/110 VC063/130	9384	
	9.3	521	3	150					12274	
	7.8	543*	0.7*	180				VR080/090	8180	
	7	685	1.7	200					VC050/110 VC063/130 VC063/150	10320
	7	685	2.3	200						13500
	7	685	3	200				18000		
	5.8	700*	0.9*	240	VR080/110	10320				
	5.6	835	1.4	250		VC050/110 VC063/130 VC063/150	10320			
	5.6	835	1.8	250			13500			
	5.6	835	2.5	250			18000			
	4.7	871	1.5	300			10320			
	4.7	908	1.9	300			13500			
	4.7	993	2.3	300			18000			
	3.5	1126	1.1	400			10320			
	3.5	1157	1.4	400			13500			
	3.5	1175	2.3	400			18000			
	2.8	1535*	0.8*	500	10320					
	2.8	1358	1.1	500	13500					
	2.8	1291	1.8	500	18000					
	2.3	1645*	0.8*	600	10320					
	2.3	1631	1	600	13500					
	2.3	1529	1.7	600	18000					
	1.9	2005*	0.9*	750	13500					
	1.9	1783	1.3	750	18000					
1.6	2283*	0.8*	900	13500						
1.6	2215*	0.9*	900	18000						
1.2	2680	1	1200	18000						
M2 090 0.75 6P. (n1 = 900 min ⁻¹)	120	52	2.9	7.5	VP063			2734		
	90	68	2.3	10	VP063			3009		
	60	97	1.6	15	VP063			3444		
	60	98	2.4	15	VP075			4065		
	45	123	1.2	20	VP063			3791		
	45	126	1.9	20	VP075			4474		
	36	149*	0.9*	25	VP063			4084		
	36	153	1.4	25	VP075			4820		
	30	167	1	30	VP063			4339		
	30	174	1.5	30	VP075			5122		
	30	179	2.6	30	VP090			5667		
	22.5	210*	0.8*	40	VP063			4776		
	22.5	216	1.1	40	VP075			5637		
	22.5	226	1.8	40	VP090			6238		
	22.5	239	3.3	40	VP110			9931		
	18	255	1	50	VP075			6073		
	18	271	1.4	50	VP090			6719		
	18	287	2.6	50	VP110			10320		
	15	296*	0.8*	60	VP075			6453		
	15	306	1.1	60	VP090			7140		
	15	325	2.1	60	VP110			9023		
	12.2	393	3.2	73.5	VR090/110			9614		
	11.3	401	1.4	80				VP110	9931	
	11.3	407	2.1	80				VP130	12989	
	9.2	508	2.3	98	VR090/110			10320		
	9	462	1.1	100				10320		
	9	470	1.7	100				13500		
	7.3	607	1.8	122.5				10320		
	6.1	682	1.5	147				10320		
	4.6	832	1.0	196				10320		
3.7	944	1.2	245	VR090/130	13500					

* **NOTA:** la coppia massima utilizzabile M_{m2} deve essere determinata utilizzando il fattore di servizio fs : $M_{m2} = M_2 \times fs$

* **NOTE:** Maximun allowable torque M_{m2} must be calculated using service factor fs : $M_{m2} = M_2 \times fs$

Tabella dati tecnici motoriduttori / Table technical data gearmotors

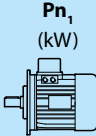
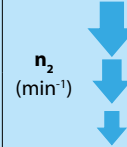
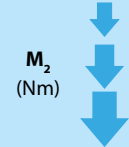
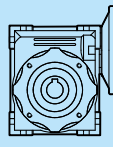
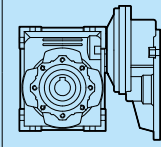
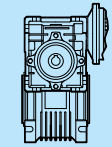
 Pn_1 (kW)	 n_2 (min ⁻¹)	 M_2 (Nm)	fs	i				FR_2 (N)
1.10								
M2 080 1.10 2P. (n1 = 2800 min ⁻¹)	373.3	25	2.1	7.5	VP050			1433
	280	33	1.7	10	VP050			1577
	280	33	3	10	VP063			2061
	186.7	48	1.2	15	VP050			1805
	186.7	46	2.1	15	VP063			2359
	186.7	50	3.3	15	VP075			2785
	140	62*	0.9*	20	VP050			1987
	140	60	1.6	20	VP063			2597
	140	65	2.7	20	VP075			3065
	112	72	1.2	25	VP063			2797
	112	77	2	25	VP075			3302
	112	81	3.1	25	VP090			3653
	93.3	87*	0.7*	30	VP050			2274
	93.3	82	1.4	30	VP063			2973
	93.3	89	1.9	30	VP075			3509
	93.3	93	3.3	30	VP090			3882
	70	104	1	40	VP063			3272
	70	114	1.4	40	VP075			3862
	70	120	2.3	40	VP090			4273
	56	137	1.1	50	VP075			4160
	56	145	1.8	50	VP090			4603
	56	150	3.3	50	VP110			5816
	46.7	158*	0.9*	60	VP075			4421
	46.7	169	1.5	60	VP090			4891
	46.7	176	2.7	60	VP110			6181
	35	201*	0.7*	80	VP075			4865
	35	210	1.1	80	VP090			5383
35	222	1.8	80	VP110			6803	
28	248*	0.8*	100	VP090			5799	
28	263	1.4	100	VP110			7328	
9.3	621	1.9	300			VC050/110	10320	
7	810	1.4	400			VC050/110	10320	
5.6	938	1.1	500			VC050/110	10320	
M2 090 1.10 6P. (n1 = 900 min ⁻¹)	120	76	2	7.5	VP063			2734
	120	77	2.8	7.5	VP075			3227
	90	99	1.5	10	VP063			3009
	90	100	2.3	10	VP075			3551
	60	142	1.1	15	VP063			3444
	60	144	1.6	15	VP075			4065
	60	149	3.1	15	VP090			4498
	45	180*	0.8*	20	VP063			3791
	45	184	1.3	20	VP075			4474
	45	195	2.2	20	VP090			4951
	36	225	1	25	VP075			4820
	36	231	1.6	25	VP090			5333
	36	239	3.2	25	VP110			6739
	30	256	1	30	VP075			5122
	30	263	1.8	30	VP090			5667
	30	270	3.1	30	VP110			7161
	22.5	322*	0.9*	40	VP075			5637
	22.5	331	1.2	40	VP090			6238
	22.5	345	2.3	40	VP110			7882
	18	397	1	50	VP090			6719
	18	414	1.8	50	VP110			8491
	15	448*	0.8*	60	VP090			7140
	15	476	1.4	60	VP110			9023
	12.2	576	2.2	73.5		VR090/110		9614
	11.3	588	1	80	VP110			9931
	11.3	598	1.4	80	VP130			12989
	9.2	746	1.6	98		VR090/110		10320

* **NOTA:** la coppia massima utilizzabile M_{m2} deve essere determinata utilizzando il fattore di servizio fs : $M_{m2} = M_2 \times fs$

* **NOTE:** Maximun allowable torque M_{m2} must be calculated using service factor fs : $M_{m2} = M_2 \times fs$

Tabella dati tecnici motoriduttori / Table technical data gearmotors

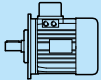
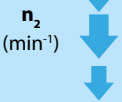
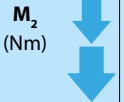
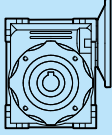
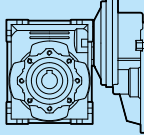
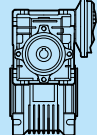
 Pn_1 (kW)	 n_2 (min^{-1})	 M_2 (Nm)	fs	i				FR_2 (N)
1.10								
M2 090 1.10 4P. ($n_1 = 1400 min^{-1}$)	9	686	1.1	100	VP130			13500
	7.3	890	1.2	122.5		VR090/110		10320
	6.1	1000	1	147		VR090/110		10320
	186.7	50	2.6	7.5	VP063			2359
	140	65	2	10	VP063			2597
	140	66	3	10	VP075			3065
	93.3	93	1.5	15	VP063			2973
	93.3	96	2.1	15	VP075			3509
	70	122	1.1	20	VP063			3272
	70	123	1.7	20	VP075			3862
	70	128	3.1	20	VP090			4273
	56	146*	0.9*	25	VP063			3524
	56	150	1.3	25	VP075			4160
	56	156	2.4	25	VP090			4603
	46.7	167	1	30	VP063			3745
	46.7	171	1.3	30	VP075			4421
	46.7	178	2.4	30	VP090			4891
	35	216	1	40	VP075			4865
	35	225	1.6	40	VP090			5383
	35	237	3	40	VP110			6803
	28	263*	0.9*	50	VP075			5241
	28	270	1.3	50	VP090			5799
	28	281	2.3	50	VP110			7328
	23.3	297*	0.7*	60	VP075			5569
	23.3	311	1	60	VP090			6163
	23.3	324	1.9	60	VP110			7787
	19	392	2.5	73.50		VR090/110		8298
	17.5	384	1	80	VP090			6783
	17.5	402	1.3	80	VP110			8571
	17.5	408	2.1	80	VP130			11210
	14.3	508	1.8	98		VR090/110		9133
	14	473	1	100	VP110			9232
	14	480	1.5	100	VP130			12076
	14	542	2.1	100			VC063/130	10722
	11.4	599	1.5	122.5		VR090/110		9838
	9.5	686	1.1	147		VR090/110		10320
	9.3	764	2.1	150			VC063/130	12274
	9.3	753	3.1	150			VC063/150	18000
	7.1	828*	0.8*	196		VR090/110		10320
	7	1005	1.6	200			VC063/130	13500
7	966	2.4	200			VC063/150	18000	
5.7	962*	0.9*	245		VR090/130		13500	
5.6	1224	1.2	250			VC063/130	13500	
5.6	1175	1.7	250			VC063/150	18000	
4.7	1312	1.3	300			VC063/130	13500	
4.7	1364	1.7	300			VC063/150	18000	
3.5	1671	1	400			VC063/130	13500	
3.5	1619	1.6	400			VC063/150	18000	
2.8	1991*	0.8*	500			VC063/130	13500	
2.8	1893	1.2	500			VC063/150	18000	
2.3	2510*	0.7*	600			VC063/130	13500	
2.3	2242	1.2	600			VC063/150	18000	
1.9	2616*	0.9*	750			VC063/150	18000	

* **NOTA:** la coppia massima utilizzabile M_{m2} deve essere determinata utilizzando il fattore di servizio fs : $M_{m2} = M_2 \times fs$

* **NOTE:** Maximun allowable torque M_{m2} must be calculated using service factor fs : $M_{m2} = M_2 \times fs$

Tabella dati tecnici motoriduttori / Table technical data gearmotors

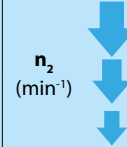
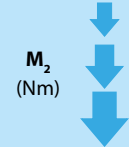
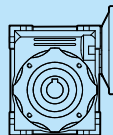
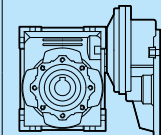
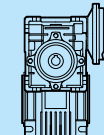
 Pn_1 (kW)	 n_2 (min ⁻¹)	 M_2 (Nm)	fs	i				FR_2 (N)
1.50								
M2 100 1.50 6P. (n1 = 900 min ⁻¹)	120	105	2	7.5	VP075			3227
	90	137	1.7	10	VP075			3551
	90	138	2.7	10	VP090			3929
	60	196	1.2	15	VP075			4065
	60	201	2.1	15	VP090			4498
	45	255	1.1	20	VP075			4474
	45	258	1.5	20	VP090			4951
	45	264	2.7	20	VP110			6256
	36	311*	0.8*	25	VP075			4820
	36	314	1.2	25	VP090			5333
	36	322	2.4	25	VP110			6739
	36	330	3.2	25	VP130			8814
	30	354*	0.8*	30	VP075			5122
	30	358	1.3	30	VP090			5667
	30	363	2.3	30	VP110			7161
	30	377	3.1	30	VP130			9366
	22.5	459	1	40	VP090			6238
	22.5	471	1.7	40	VP110			7882
	22.5	478	2.3	40	VP130			10309
	18	565	1.3	50	VP110			8491
18	573	1.8	50	VP130			11105	
18	589	2.7	50	VP150			15182	
15	649	1.1	60	VP110			9023	
15	659	1.4	60	VP130			11801	
15	678	2.1	60	VP150			16133	
11.3	815	1.1	80	VP130			12989	
11.3	841	1.5	80	VP150			17757	
9	955*	0.8*	100	VP130			13500	
9	971	1.2	100	VP150			18000	
M2 090 1.50 4P. (n1 = 1400 min ⁻¹)	186.7	68	1.9	7.5	VP063			2359
	186.7	68	2.7	7.5	VP075			2785
	140	89	1.5	10	VP063			2597
	140	90	2.2	10	VP075			3065
	93.3	127	1.1	15	VP063			2973
	93.3	130	1.5	15	VP075			3509
	93.3	134	3	15	VP090			3882
	70	166*	0.8*	20	VP063			3272
	70	168	1.3	20	VP075			3862
	70	172	2.1	20	VP090			4273
	56	205	1	25	VP075			4160
	56	210	1.6	25	VP090			4603
	56	218	3.1	25	VP110			5816
	46.7	233	1	30	VP075			4421
	46.7	239	1.7	30	VP090			4891
	46.7	246	3	30	VP110			6181
	35	299*	0.8*	40	VP075			4865
	35	307	1.2	40	VP090			5383
	35	319	2.2	40	VP110			6803
	28	368*	0.9*	50	VP090			5799
	28	384	1.7	50	VP110			7328
	23.3	424*	0.8*	60	VP090			6163
	23.3	442	1.4	60	VP110			7787
	19	535	1.9	73.5		VR090/110		8298
	17.5	548*	0.9*	80	VP110			8571
	17.5	557	1.5	80	VP130			11210
	14.3	693	1.3	98		VR090/110		9133
	14	655	1.1	100	VP130			12076
	14	739	1.5	100			VC063/130	10722
	11.4	817	1.1	122.5		VR090/110		9838
9.5	936*	0.8*	147		VR090/110		10320	
9.3	1042	1.5	150			VC063/130	12274	
9.3	1026	2.3	150			VC063/150	18000	
7.1	1149*	0.8*	196		VR090/130		13500	

* **NOTA:** la coppia massima utilizzabile M_{m2} deve essere determinata utilizzando il fattore di servizio fs : $M_{m2} = M_2 \times fs$

* **NOTE:** Maximun allowable torque M_{m2} must be calculated using service factor fs : $M_{m2} = M_2 \times fs$

Tabella dati tecnici motoriduttori / Table technical data gearmotors

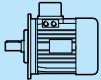
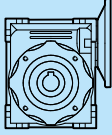
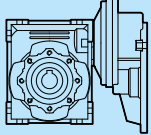
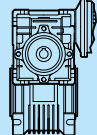
 Pn_1 (kW)	n_2 (min^{-1})	M_2 (Nm)	fs	i	  	FR_2 (N)			
1.50									
M2 090 1.50 4P. ($n_1 = 1400 min^{-1}$)	7	1371	1.2	200	VR090/130	VC063/130	13500		
	7	1317	1.8	200		VC063/150	18000		
	5.7	962*	0.9*	245		VC063/130	13500		
	5.6	1669*	0.9*	250		VC063/150	18000		
	5.6	1602	1.3	250		VC063/130	13500		
	4.7	1789	1	300		VC063/150	18000		
	4.7	1860	1.3	300		VC063/130	13500		
	3.5	2279*	0.7*	400		VC063/150	18000		
	3.5	2208	1.2	400		VC063/130	13500		
	2.8	2582*	0.9*	500		VC063/150	18000		
	2.3	3057*	0.9*	600		VC063/150	18000		
	M2 090 1.50 2P. ($n_1 = 2800 min^{-1}$)	373	35	2.7		7.5	VP063		1873
		280	45	2.2		10	VP063		2061
280		45	3.2	10	VP075		2433		
186.7		66	1.6	15	VP063		2359		
186.7		66	2.3	15	VP075		2785		
140		86	1.2	20	VP063		2597		
140		86	1.9	20	VP075		3065		
140		90	2.9	20	VP090		3391		
112		105*	0.9*	25	VP063		2797		
112		105	1.4	25	VP075		3302		
112		110	2.3	25	VP090		3653		
93.3		120	1	30	VP063		2973		
93.3		121	1.4	30	VP075		3509		
93.3		127	2.4	30	VP090		3882		
70		156*	0.7*	40	VP063		3272		
70		156	1.1	40	VP075		3862		
70		164	1.7	40	VP090		4273		
70		170	3.1	40	VP110		5399		
56		187	1.3	50	VP075		4160		
56		197	1.3	50	VP090		4603		
56		205	2.4	50	VP110		5816		
46.7		215	1.1	60	VP075		4421		
46.7		227	1.1	60	VP090		4891		
46.7		236	2	60	VP110		6181		
35		287*	0.8*	80	VP090		5383		
35		299	1.3	80	VP110		6803		
28		358	1	100	VP110		7328		
9.3		847	1.4	300		VC050/110	10320		
9.3		878	1.9	300		VC063/130	13500		
7		1105	1	400		VC050/110	10320		
7		1105	1.4	400		VC063/130	13500		
5.6		1279*	0.8*	500		VC050/110	10320		
5.6		1305	1.1	500		VC063/130	13500		
2.20									
M2 100 2.20 4P. ($n_1 = 1400 min^{-1}$)	186.7	100	1.8	7.5	VP075		2785		
	186.7	101	2.9	7.5	VP090		3081		
	140	132	1.5	10	VP075		3065		
	140	134	2.3	10	VP090		3391		
	93.3	191	1	15	VP075		3509		
	93.3	194	1.9	15	VP090		3882		
	93.3	196	3.3	15	VP110		4905		
	70	249*	0.9*	20	VP075		3862		
	70.00	252	1.4	20	VP090		4273		
	70	255	2.5	20	VP110		5399		
	56	304*	0.7*	25	VP075		4160		
	56.00	308	1.1	25	VP090		4603		
	56	315	2.2	25	VP110		5816		
	56	319	2.9	25	VP130		7607		
	46.7	347*	0.7*	30	VP075		4421		
	46.70	351	1.2	30	VP090		4891		
	46.7	356	2	30	VP110		6181		

* **NOTA:** la coppia massima utilizzabile M_{m2} deve essere determinata utilizzando il fattore di servizio fs : $M_{m2} = M_2 \times fs$

* **NOTE:** Maximun allowable torque M_{m2} must be calculated using service factor fs : $M_{m2} = M_2 \times fs$

Tabella dati tecnici motoriduttori / Table technical data gearmotors

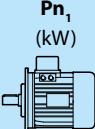
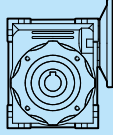
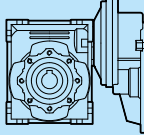
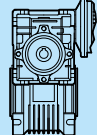
 Pn_1 (kW)	n_2 (min^{-1})	M_2 (Nm)	fs	i				FR_2 (N)
2.20								
M2 100 2.20 4P. ($n_1 = 1400 \text{ min}^{-1}$)	46.7	365	2.9	30	VP130			8084
	35	468	1.5	40	VP110			6803
	35	468	2.2	40	VP130			8897
	30.00	456*	0.9*	40	VP090			5383
	28	563	1.2	50	VP110			7328
	28	563	1.7	50	VP130			9584
	28	570	2.5	50	VP150			13103
	23.3	648	1.0	60	VP110			7787
	23.3	648	1.4	60	VP130			10185
	23.3	657	1.9	60	VP150			13924
	17.5	816	1	80	VP130			11210
	17.5	816	1.4	80	VP150			15325
	14.0	976	1	100	VP130			12076
	14	960	1	100	VP150			16508
M2 112 2.20 6P. ($n_1 = 900 \text{ min}^{-1}$)	120	154	1.4	7.5	VP075			3227
	120	156	2.2	7.5	VP090			3570
	90	201	1.1	10	VP075			3551
	90	203	1.8	10	VP090			3929
	90	205	3.5	10	VP110			4965
	60	291*	0.9*	15	VP075			4065
	60	294	1.4	15	VP090			4498
	60	298	2.6	15	VP110			5684
	45	374*	0.7*	20	VP075			4474
	45	532*	0.9*	30	VP090			5667
	45	378	1	20	VP090			4951
	45	388	1.9	20	VP110			6256
	36	467*	0.9*	25	VP090			5333
	36	473	1.6	25	VP110			6739
	36	479	2.2	25	VP130			8814
	30	532	1.6	30	VP110			7161
	30	546	2.1	30	VP130			9366
	22.5	701	1.1	40	VP110			7882
	22.5	700	1.6	40	VP130			10309
	18	841*	0.9*	50	VP110			8491
	18	840	1.2	50	VP130			11105
	18	864	1.9	50	VP150			15182
	15	967*	0.7*	60	VP110			9023
	15	966	1	60	VP130			11801
	15	995	1.4	60	VP150			16133
	11.3	1214*	0.7*	80	VP130			12898
	11.3	1233	1.1	80	VP150			17757
9	1425*	0.8*	100	VP150			18000	
M2 090 2.20 2P. ($n_1 = 2800 \text{ min}^{-1}$)	373.3	51	1.8	7.5	VP063			1873
	373.3	50	2.6	7.5	VP075			2210
	280	66	1.5	10	VP063			2061
	280	66	2.2	10	VP075			2433
	280	68	3.5	10	VP090			2692
	186.7	97	1.1	15	VP063			2359
2.20								
M2 090 2.20 2P. ($n_1 = 2800 \text{ min}^{-1}$)	186.7	97	1.5	15	VP075			2785
	186.7	100	2.7	15	VP090			3081
	140	128*	0.8*	20	VP063			2597
	140	126	1.3	20	VP075			3065
	140	129	2	20	VP090			3391
	112	154	1	25	VP075			3302
	112	159	1.6	25	VP090			3653
	112	161	3.1	25	VP110			4616
	93.3	178	1	30	VP075			3509
	93.3	185	1.7	30	VP090			3882
	93.3	187	3	30	VP110			4905

* **NOTA:** la coppia massima utilizzabile M_{m2} deve essere determinata utilizzando il fattore di servizio fs : $M_{m2} = M_2 \times fs$

* **NOTE:** Maximun allowable torque M_{m2} must be calculated using service factor fs : $M_{m2} = M_2 \times fs$

Tabella dati tecnici motoriduttori / Table technical data gearmotors

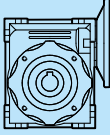
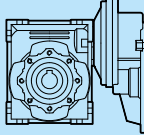
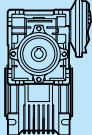
 Pn_1 (kW)	n_2 (min^{-1})	M_2 (Nm)	fs	i				FR_2 (N)
2.20								
M2 090 2.20 2P. ($n_1 = 2800 min^{-1}$)	70	234*	0.8*	40	VP075			3862
	70	237	1.2	40	VP090			4273
	70	243	2.2	40	VP110			5399
	56	289*	0.9*	50	VP090			4603
	56	296	1.7	50	VP110			5816
	46.7	347	1.4	60	VP110			6181
	38.6	398	2.1	73.5		VR090/110		6586
	35	444*	0.9*	80	VP110			
	35	444	1.3	80	VP130			8897
	28.9	516	1.5	98		VR090/110		7249
	28	525*	0.7*	100	VP110			
	28	525	1	100	VP130			9584
	23.1	617	1.2	122.5		VR090/110		7809
	3.00							
M2 100 3.00 2P. ($n_1 = 2800 min^{-1}$)	373.3	68	1.9	7.5	VP075			2210
	373.3	70	3	7.5	VP090			2446
	280	90	1.6	10	VP075			2433
	280	92	2.6	10	VP090			2692
	186.7	135	1.2	15	VP075			2785
	186.7	137	2	15	VP090			3081
	140	176	1	20	VP075			3065
	140	180	1.4	20	VP090			3391
	140	182	2.7	20	VP110			4285
	112	215*	0.7*	25	VP075			3302
	112	220	1.1	25	VP090			3653
	112	225	2.2	25	VP110			4616
	93.3	249*	0.7*	30	VP075			3509
	93.3	255	1.2	30	VP090			3882
	93.3	258	2.1	30	VP110			4905
	70	328*	0.8*	40	VP090			4273
	70	340	1.6	40	VP110			5399
	56	409	1.2	50	VP110			5816
	46.7	479	1	60	VP110			6181
	M2 100 3.00 4P. ($n_1 = 1400 min^{-1}$)	186.7	137	1.4	7.5	VP075		
186.7		138	2.1	7.5	VP090			3081
140		180	1.1	10	VP075			3065
140		182	1.7	10	VP090			3391
140		182	3.3	10	VP110			4285
93.3		261*	0.8*	15	VP075			3509
93.3		264	1.4	15	VP090			3882
93.3		264	2.5	15	VP110			4905
70		344	1	20	VP090			4273
70		348	1.9	20	VP110			5399
56		420*	0.8*	25	VP090			4603
56		430	1.6	25	VP110			5816
56		430	2.2	25	VP130			7607
46.7		479*	0.9*	30	VP090			4891
46.7		485	1.5	30	VP110			6181
46.7		491	2.1	30	VP130			8084
35		638	1.1	40	VP110			6803
35		638	1.6	40	VP130			8897
28		767*	0.9*	50	VP110			7328
28		767	1.3	50	VP130			9584

* **NOTA:** la coppia massima utilizzabile M_{m2} deve essere determinata utilizzando il fattore di servizio fs : $M_{m2} = M_2 \times fs$

* **NOTE:** Maximun allowable torque M_{m2} must be calculated using service factor fs : $M_{m2} = M_2 \times fs$

Tabella dati tecnici motoriduttori / Table technical data gearmotors

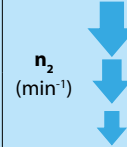
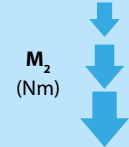
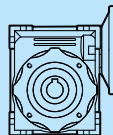
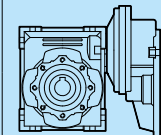
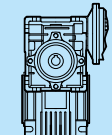
 Pn_1 (kW)	 n_2 (min^{-1})	 M_2 (Nm)	fs	i				FR_2 (N)
3.00								
M2 100 3.00 4P. ($n_1 = 1400 min^{-1}$)	28	778	1.8	50	VP150			13103
	23.3	884	1	60	VP130			10185
	23.3	896	1.4	60	VP150			13924
	17.5	1113*	0.8*	80	VP130			11210
	17.5	1113	1	80	VP150			15325
	14.00	1310*	0.8*	100	VP150			16508
M2 132 3.00 6P. ($n_1 = 900 min^{-1}$)	120	212	3.1	7.5	VP110			4511
	90	280	2.5	10	VP110			4965
	90	280	3.4	10	VP130			6494
	60	406	1.9	15	VP110			5684
	60	406	2.6	15	VP130			7434
	45	528	1.4	20	VP110			6256
	45	535	1.9	20	VP130			8182
	45	541	2.8	20	VP150			11186
	36	653	1.2	25	VP110			6739
	36	653	1.6	25	VP130			8814
	36	669	2.1	25	VP150			12050
	30	736	1.1	30	VP110			7161
	30	745	1.6	30	VP130			9366
	30	783	1.8	30	VP150			12805
	22.5	955*	0.8*	40	VP110			7882
	22.5	955	1.2	40	VP130			10309
	22.5	968	1.9	40	VP150			14094
	18	1178	1.4	50	VP150			15182
	15	1357	1.1	60	VP150			16133
	4.00							
M2 112 4.00 2P. ($n_1 = 2800 min^{-1}$)	373.3	91	1.4	7.5	VP075			2210
	373.3	93	2.3	7.5	VP090			2446
	280	120	1.2	10	VP075			2433
	280	123	1.9	10	VP090			2692
	186.7	180*	0.9*	15	VP075			2785
	186.7	182	1.5	15	VP090			3081
	140	235	0.7	20	VP075			3065
	140	240	1.1	20	VP090			3391
	112	293*	0.9*	25	VP090			3653
	93.3	340*	0.9*	30	VP090			3882
	M2 112 4.00 4P. ($n_1 = 1400 min^{-1}$)	186.7	180	1	7.5	VP075		
186.7		184	1.6	7.5	VP090			3081
187		184	3.0	8	VP110			3893
140		237*	0.8*	10	VP075			3065
140		243	1.3	10	VP090			3391
140		243	2.5	10	VP110			4285
93.3		352	1	15	VP090			3882
93.3		352	1.9	15	VP110			4905
70		458*	0.8*	20	VP090			4273
70		464	1.4	20	VP110			5399
56		573	1.2	25	VP110			5816
56		573	1.6	25	VP130			7607
46.7		647	1.1	30	VP110			6181
46.7		655	1.6	30	VP130			8084
35		863*	0.8*	40	VP110			6803
35		851	1.2	40	VP130			8897
28		1023	1	50	VP130			9584
28		1037	1.4	50	VP150			13103
23.3		1179*	0.8*	60	VP130			10185
23.3		1195	1.1	60	VP150			13924
17.5	1484*	0.8*	80	VP150			15325	
M2 132 4.00 6P. ($n_1 = 900 min^{-1}$)	120	283	2.3	7.5	VP110			4511
	120	287	3.1	7.5	VP130			5901
	90	374	1.9	10	VP110			4965
	90	374	2.6	10	VP130			6494
	60	541	1.4	15	VP110			5684

* **NOTA:** la coppia massima utilizzabile M_{m2} deve essere determinata utilizzando il fattore di servizio fs : $M_{m2} = M_2 \times fs$

* **NOTE:** Maximun allowable torque M_{m2} must be calculated using service factor fs : $M_{m2} = M_2 \times fs$

Tabella dati tecnici motoriduttori / Table technical data gearmotors

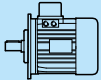
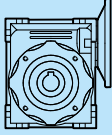
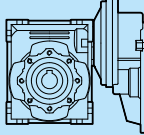
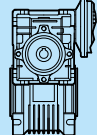
 Pn_1 (kW)	n_2 (min^{-1})	M_2 (Nm)	fs	i				FR_2 (N)	
4.00									
M2 132 4.00 6P. ($n_1 = 900 min^{-1}$)	60	541	2	15	VP130			7434	
	56	580	1.2	25	VP110			5816	
	46.7	655	1.1	30	VP110			6181	
	45	713	1.5	20	VP130			8182	
	45	722	2.1	20	VP150			11186	
	36	870	1.2	25	VP130			8814	
	36	892	1.5	25	VP150			12050	
	35	863*	0.8*	40	VP110			6803	
	30	1006	1.2	30	VP130			9366	
	30	1045	1.3	30	VP150			12805	
	22.5	1291*	0.9*	40	VP130			10309	
	22.5	1291	1.4	40	VP150			14094	
	18	1571	1	50	VP150			15182	
	15	1809*	0.8*	60	VP150			16133	
5.50									
M2 132 5.50 4P. ($n_1 = 1400 min^{-1}$)	186.7	253	2.2	7.5	VP110			3893	
	140	334	1.8	10	VP110			4285	
	140	334	2.5	10	VP130			5605	
	93.3	484	1.4	15	VP110			4905	
	93.3	490	1.9	15	VP130			6416	
	70	638	1	20	VP110			5399	
	70	645	1.4	20	VP130			7062	
	70	645	2	20	VP150			9654	
	56	798*	0.9*	25	VP110			5816	
	56	788	1.2	25	VP130			7607	
	56	788	1.5	25	VP150			10400	
	46.7	901*	0.8*	30	VP110			6181	
	46.7	900	1.2	30	VP130			8084	
	46.7	934	1.3	30	VP150			11051	
	35	1171*	0.9*	40	VP130			8897	
	35	1171	1.3	40	VP150			12163	
	28	1426	1	50	VP150			13103	
	23.3	1643*	0.8*	60	VP150			13924	
	7.50								
	M3 132 7.50 4P. ($n_1 = 1400 min^{-1}$)	186.7	345	1.6	7.5	VP110			3893
186.7		349	2.1	7.5	VP130			5092	
140		455	1.3	10	VP110			4285	
140		455	1.8	10	VP130			5605	
93.3		660	1	15	VP110			4905	
93.3		668	1.4	15	VP130			6416	
70		880*	0.7*	20	VP110			5399	
70		880	1.0	20	VP130			7062	
70		880	1.5	20	VP150			9654	
56		1074*	0.9*	25	VP130			7607	
56		1074	1.1	25	VP150			10400	
46.7		1228*	0.8*	30	VP130			8084	
46.7		1274*	0.9*	30	VP150			11051	
35		1596*	0.7*	40	VP130			8897	
35		1596	1	40	VP150			12163	
28		1971*	0.7*	50	VP150			13103	
11.0									
M3 160 11.0 4P. ($n_1 = 1400 min^{-1}$)		187	512	2.3	7.5	VP150			6962
	140	675	1.8	10	VP150			7663	
	93.3	990	1.3	15	VP150			8771	
	70	1291	1.0	20	VP150			9654	
	56	1576*	0.8*	25	VP150			10400	
15.0									
M3 160 15.0 4P. ($n_1 = 1400 min^{-1}$)	187	698	1.7	7.5	VP150			6962	
	140	921	1.3	10	VP150			7663	
	93.3	1351*	0.9*	15	VP150			8771	
	70	1760*	0.7*	20	VP150			9654	

* **NOTA:** la coppia massima utilizzabile M_{m2} deve essere determinata utilizzando il fattore di servizio fs : $M_{m2} = M_2 \times fs$

* **NOTE:** Maximun allowable torque M_{m2} must be calculated using service factor fs : $M_{m2} = M_2 \times fs$

VP 025 P ... (NMRV-025)

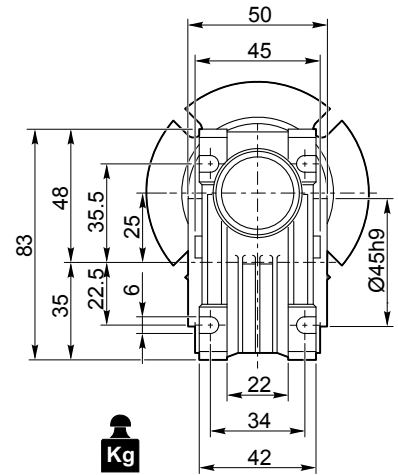
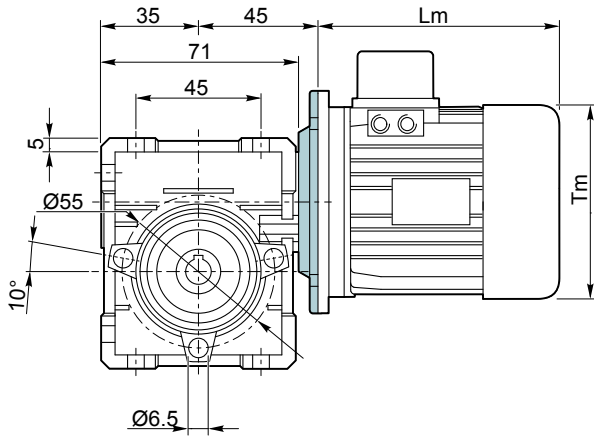

Kg
0.7 kg

Albero uscita / Output shaft

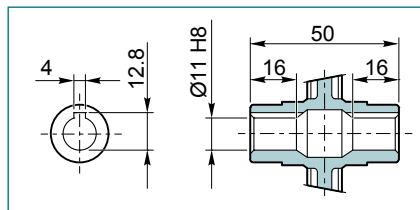
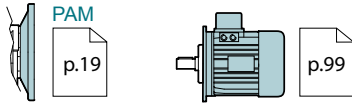

VP 025 F...

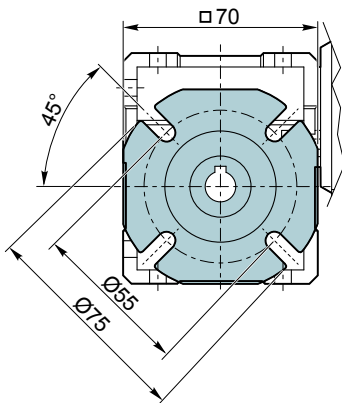

FA DX
Standard

FA SX

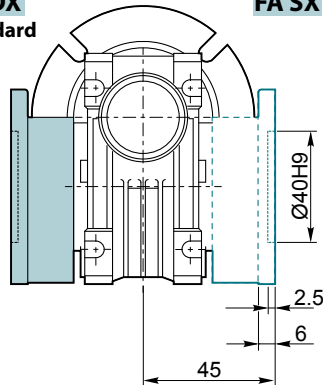

VP 030 P ... (NMRV-030)

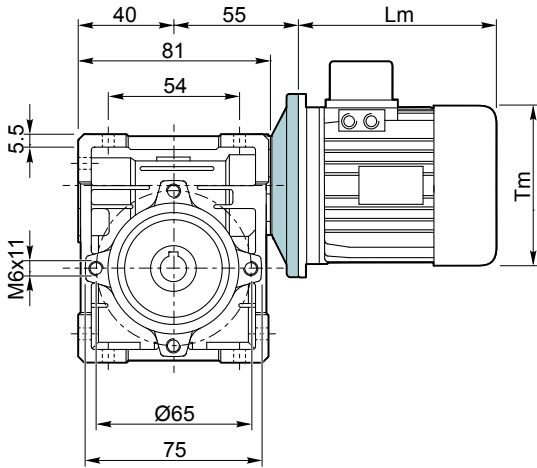

VI 030 P ...

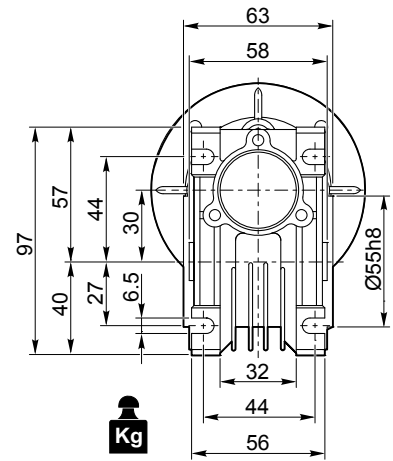
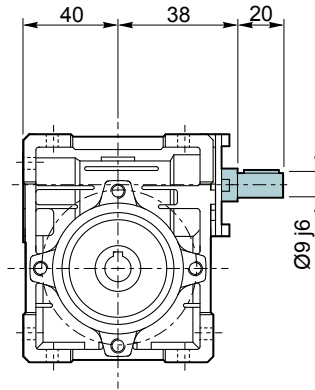

Kg
1.2 kg

Albero uscita / Output shaft

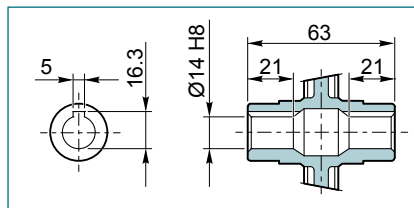

Albero entrata / Input shaft

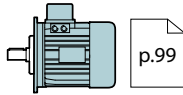
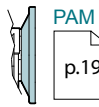
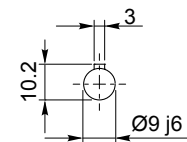

VP 030 F... / VI 030 F...

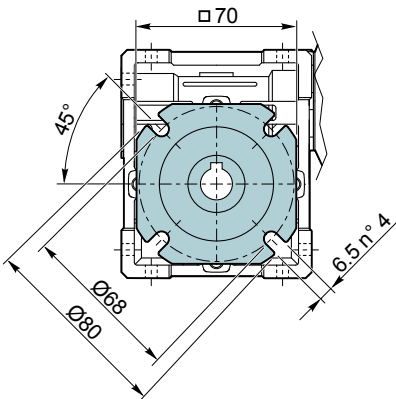

FA DX
Standard

FA SX

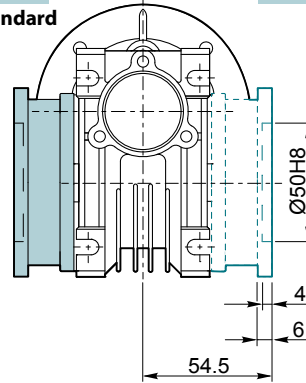

VP 040 P... (NMRV-040)

VI 040 P...

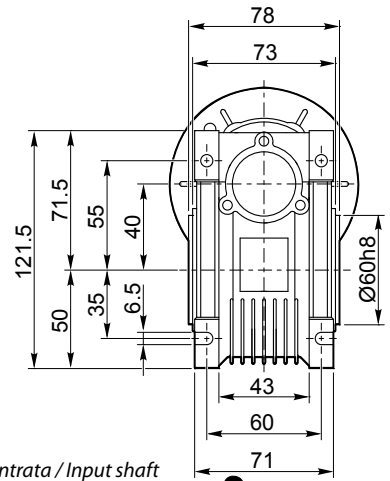
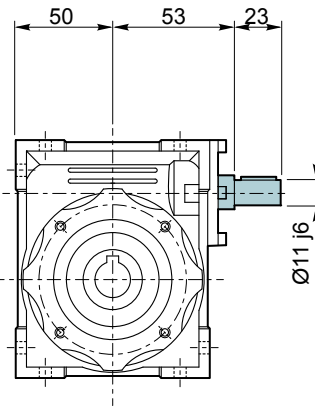
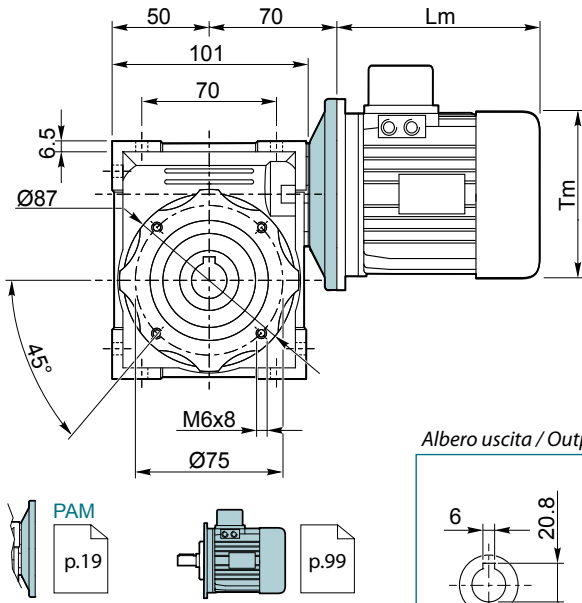

Albero uscita / Output shaft

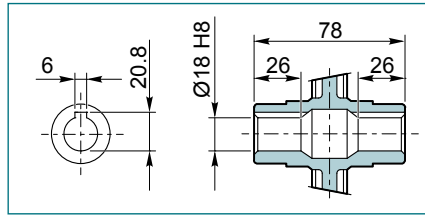

Albero entrata / Input shaft

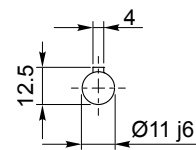

Kg
2.3 kg

VP 040 F... / VI 040 F...

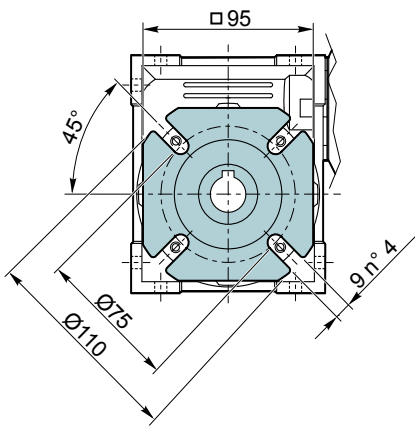

FA DX
Standard

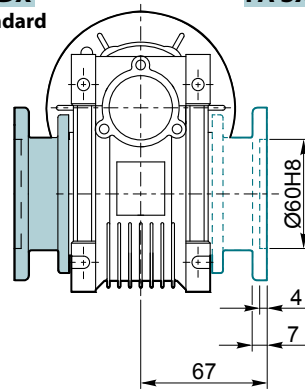

FA SX

FB DX
Standard

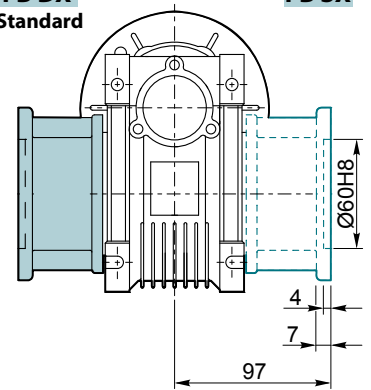

FB SX

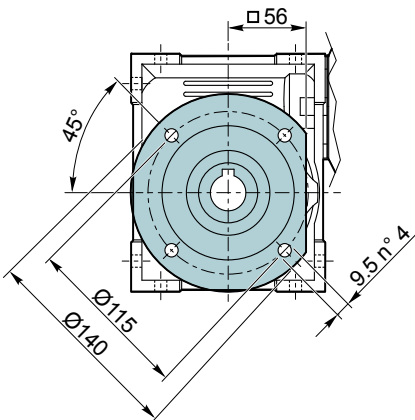

FC DX
Standard

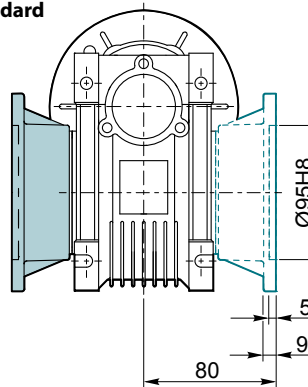

FC SX

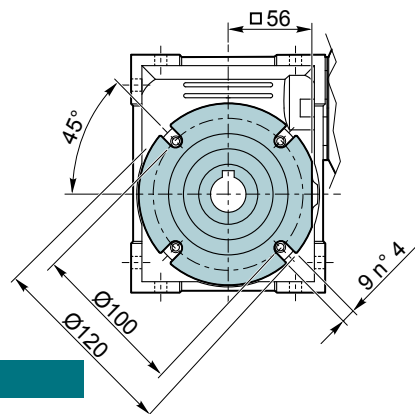

FD DX
Standard

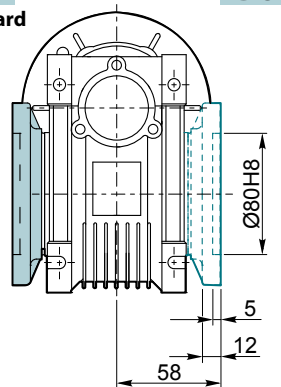

FD SX

VP 050 P ... (NMRV-050)

VI 050 P ...

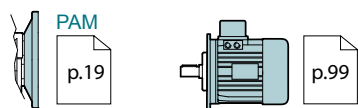
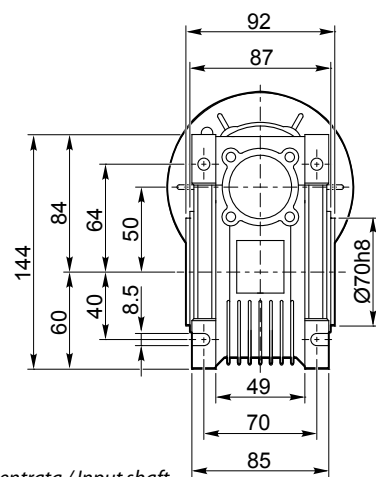
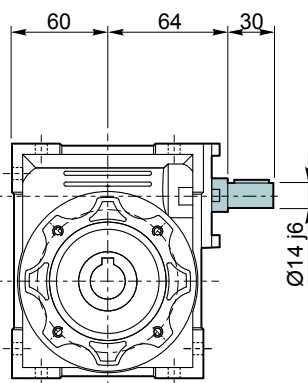
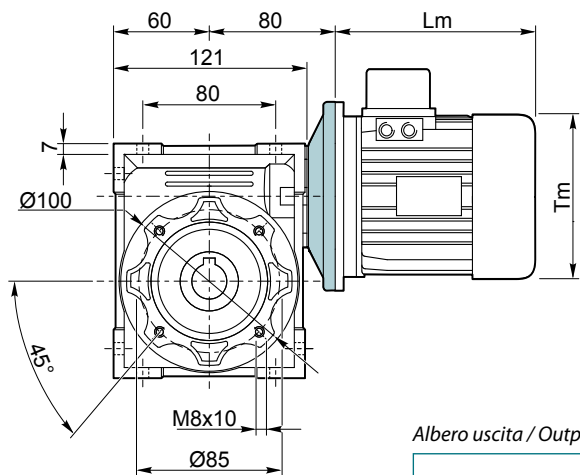

Albero uscita / Output shaft

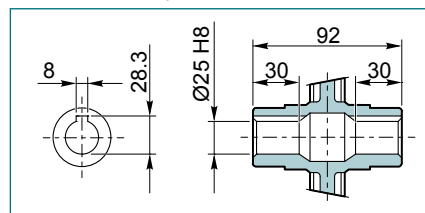

Albero entrata / Input shaft

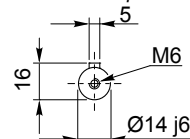

Kg
3.5 kg

VP 050 F... / VI 050 F...

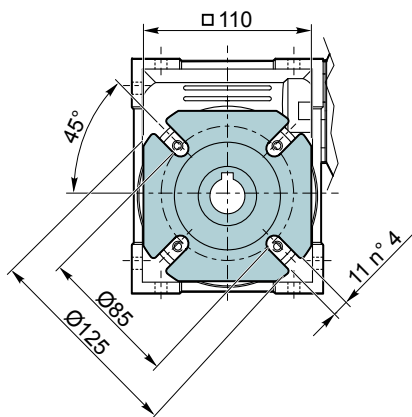

FA DX
Standard

FA SX

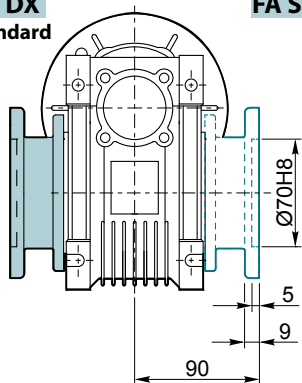

FB DX
Standard

FB SX

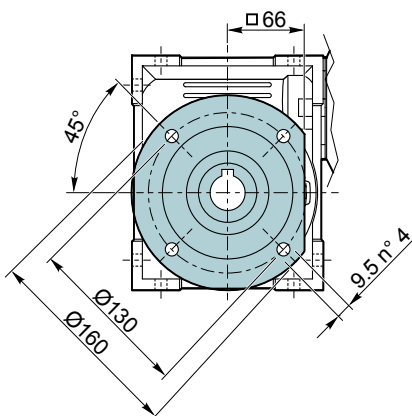
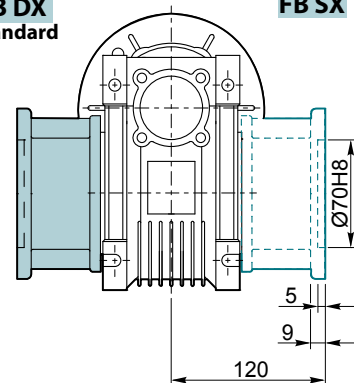

FC DX
Standard

FC SX

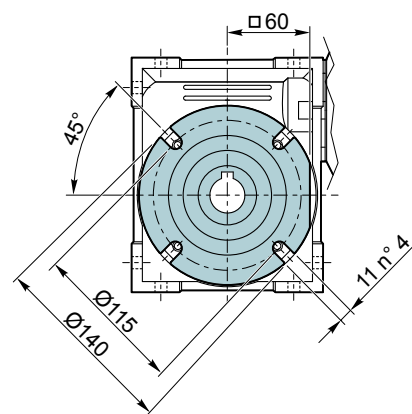
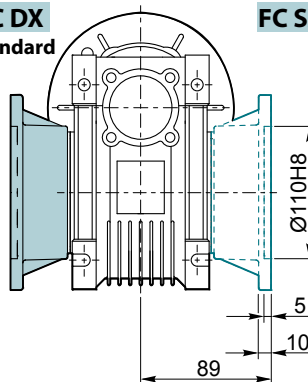

FD DX
Standard

FD SX

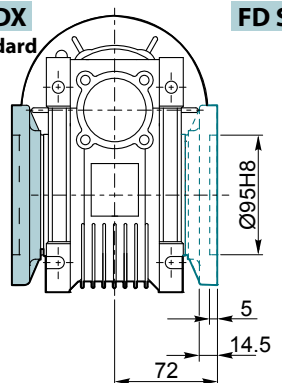

VP 063 P ... (NMRV-063)

VI 063 P ...

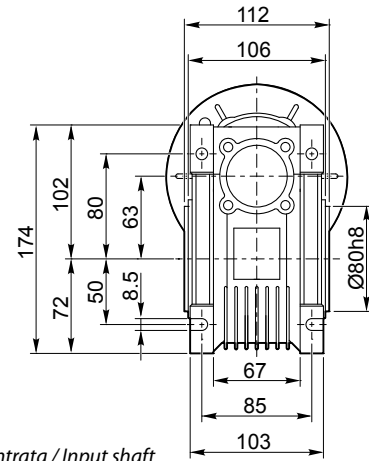
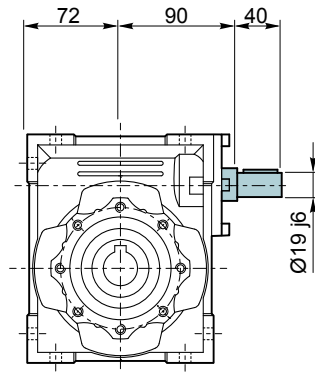
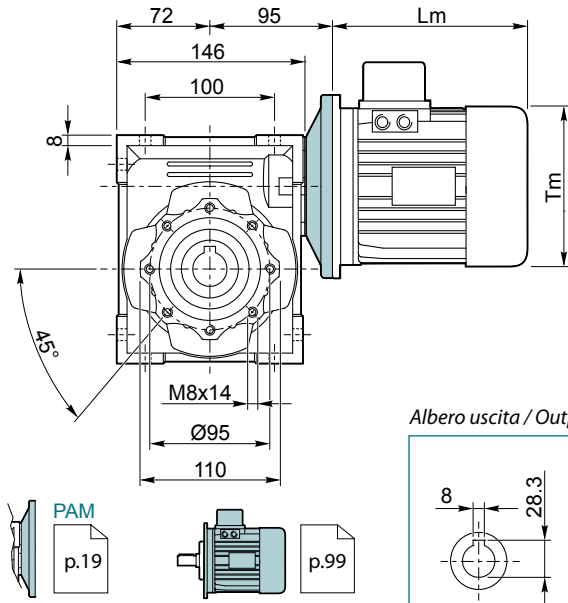

Albero uscita / Output shaft

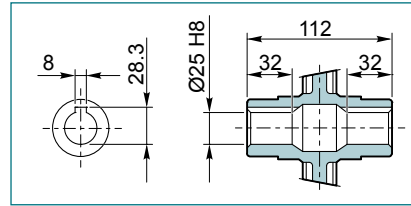

Albero entrata / Input shaft

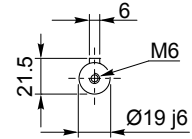

Kg
6.2 kg

VP 063 F... / VI 063 F...

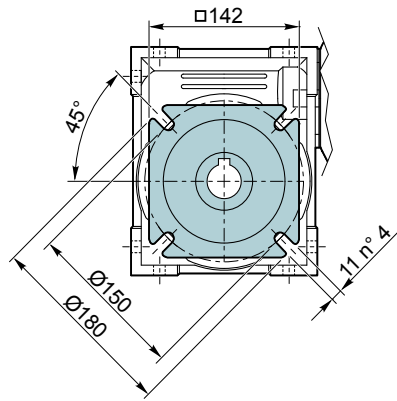

FA DX
Standard

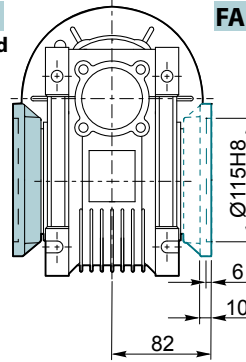

FA SX

FB DX
Standard

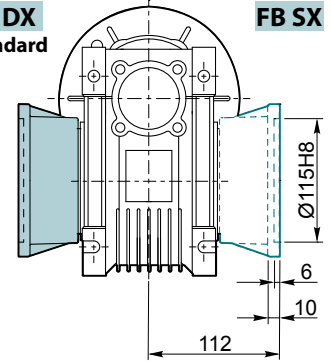

FB SX

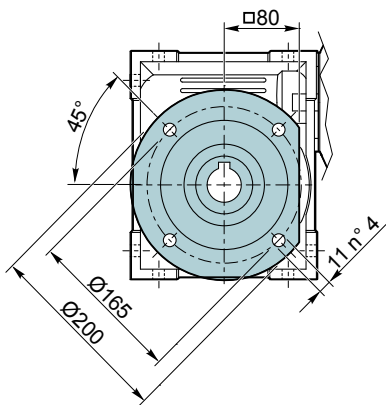

FC DX
Standard

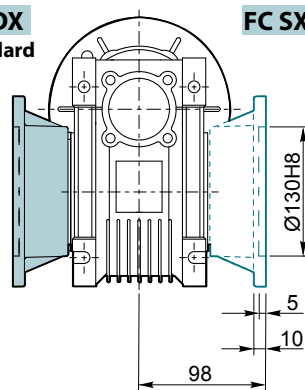

FC SX

FD DX
Standard

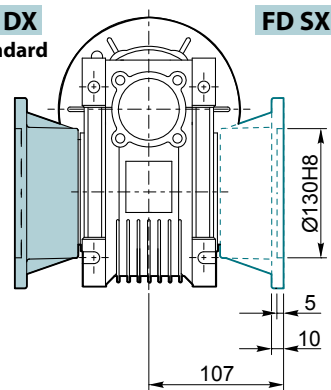

FD SX

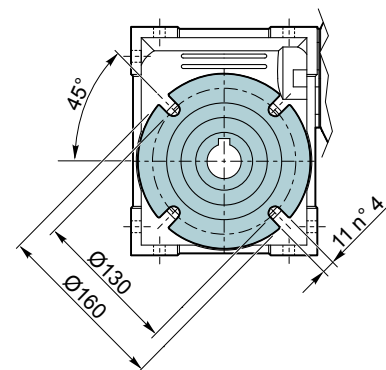

FE DX
Standard

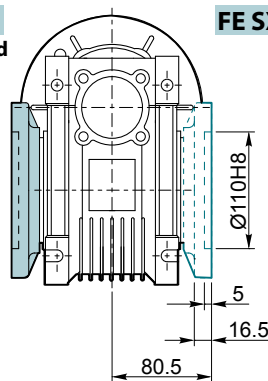

FE SX

VP 075 P... (NMRV-075)

VI 075 P...

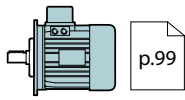
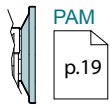
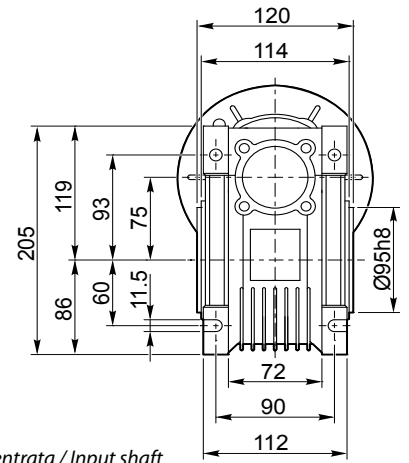
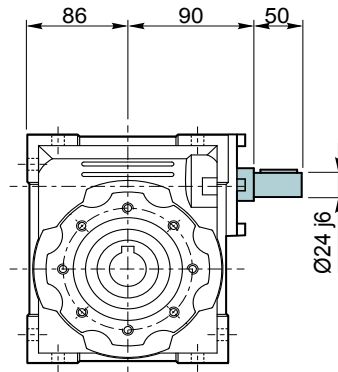
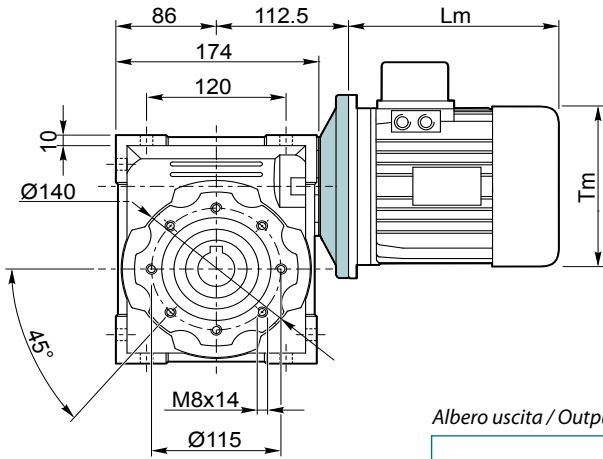

Albero uscita / Output shaft

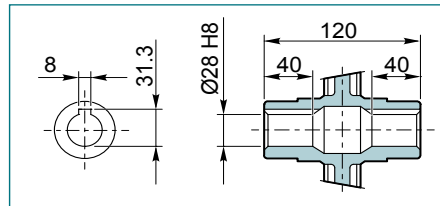

Albero entrata / Input shaft

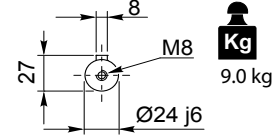

VP 075 F... / VI 075 F...

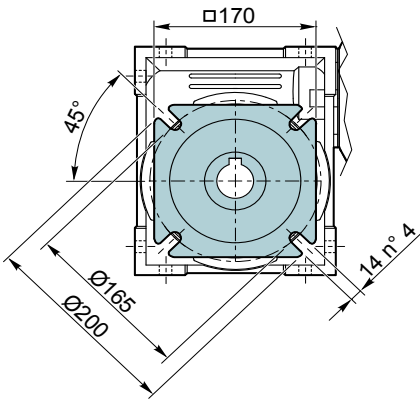

FA DX
Standard

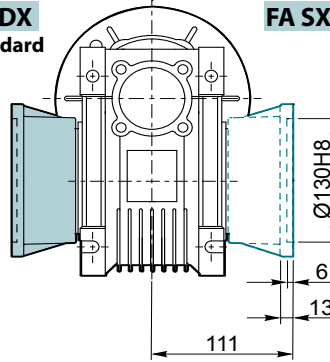

FA SX

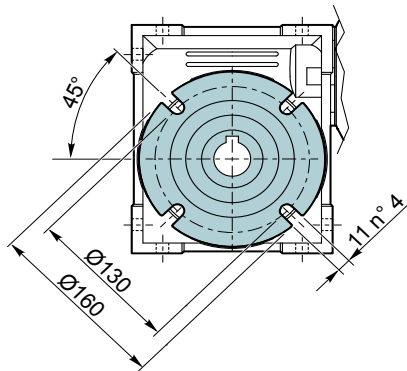

FB DX
Standard

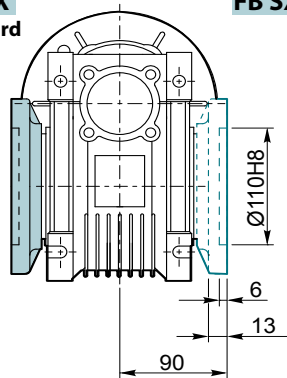

FB SX

VP 090 P ... (NMRV-090)

VI 090 P ...

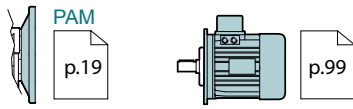
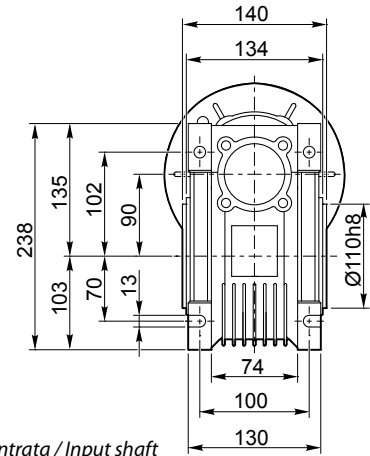
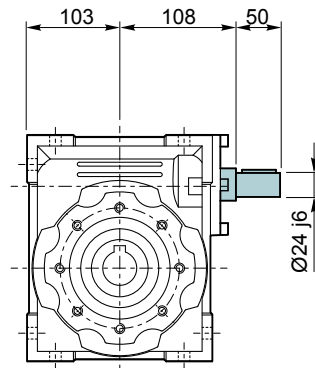
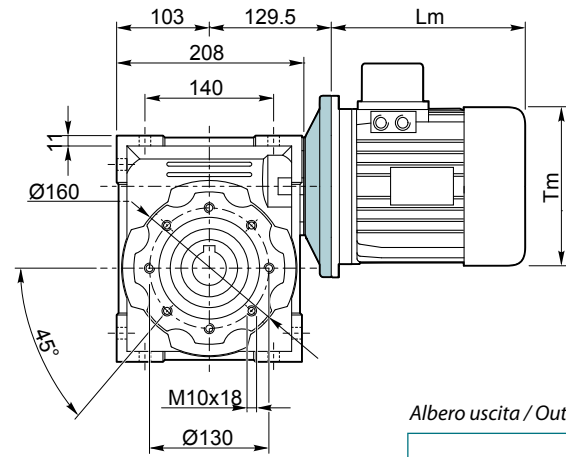

Albero uscita / Output shaft

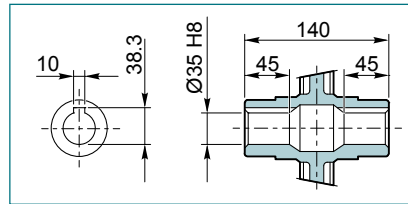

Albero entrata / Input shaft

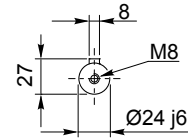

Kg
13 kg

VP 090 F... / VI 090 F...

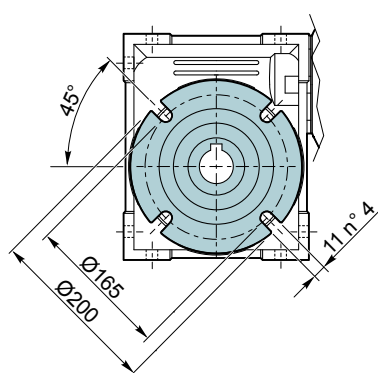
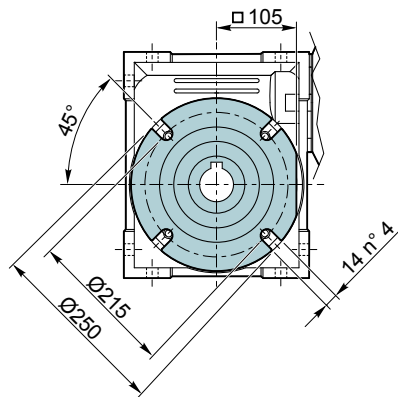
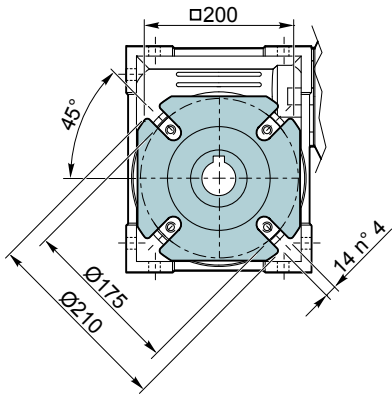

FA DX
Standard

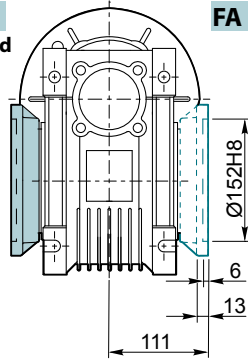

FA SX

FD DX
Standard

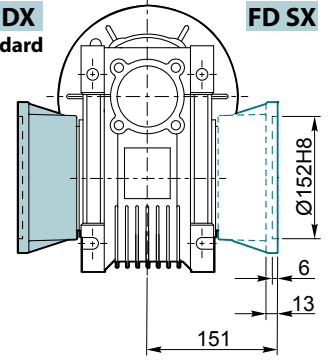

FD SX

FB DX
Standard

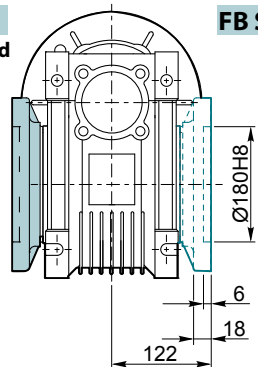

FB SX

FC DX
Standard

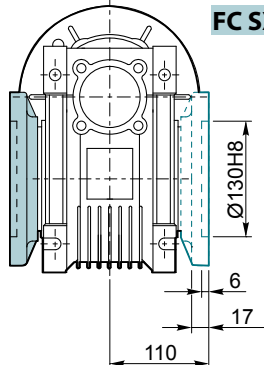

FC SX

VP 110 P... (NMRV-110)

VI 110 P...

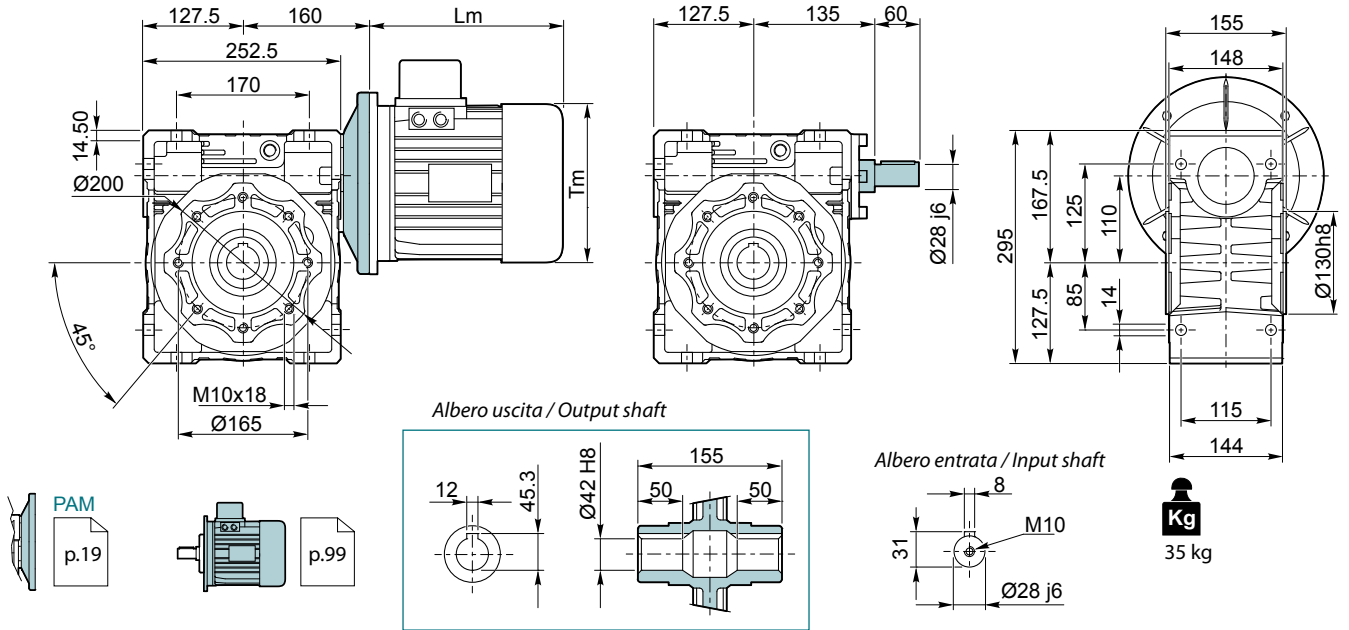

VP 110 F... / VI 110 F...

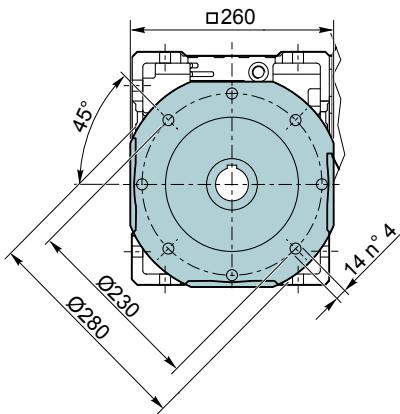

FA DX
Standard

FA SX

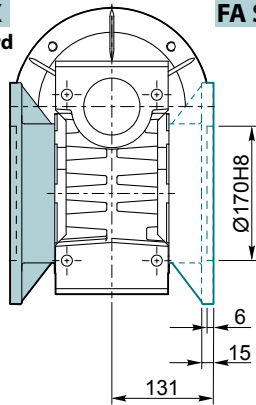

VP 130 P ... (NMRV-130)

VI 130 P ...

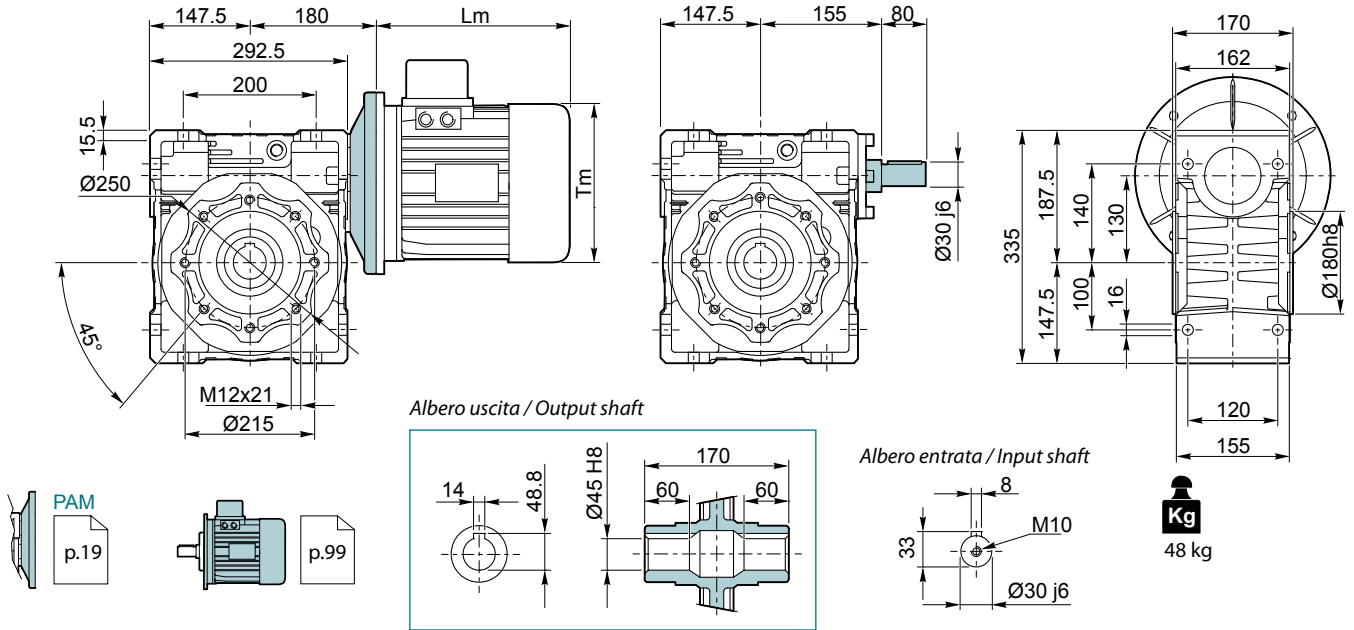

VP 130 F... / VI 130 F...

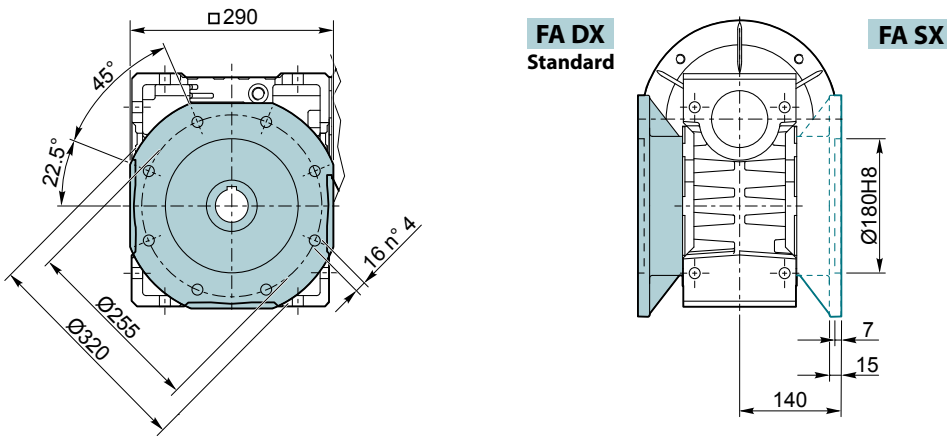

VP 150 P ... (NMRV-150)

VI 150 P ...

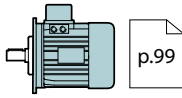
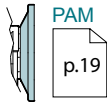
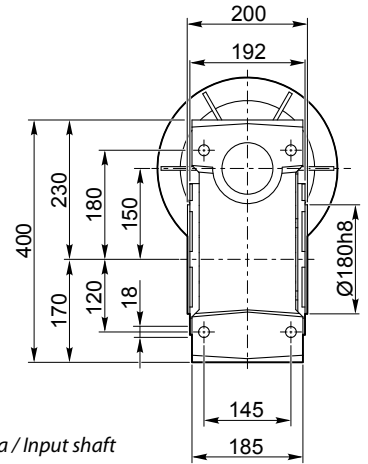
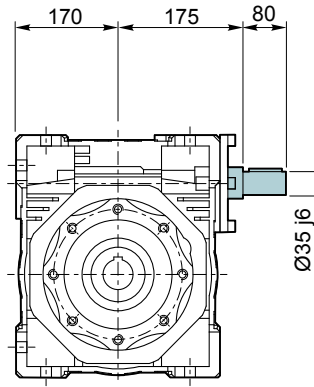
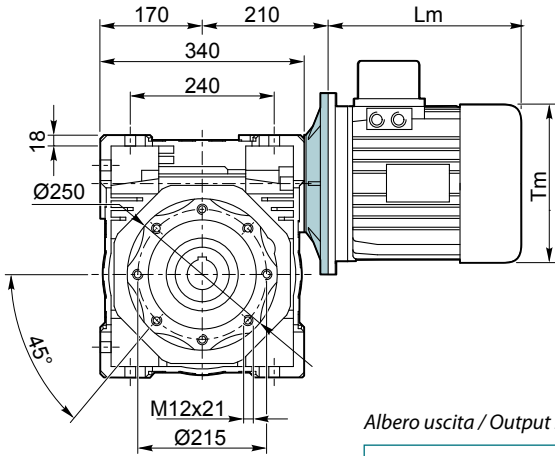

Albero uscita / Output shaft

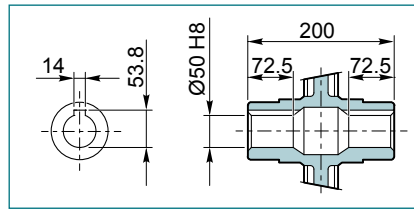

Albero entrata / Input shaft

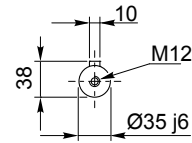

Kg
84 kg

VP 150 F... / VI 150 F...

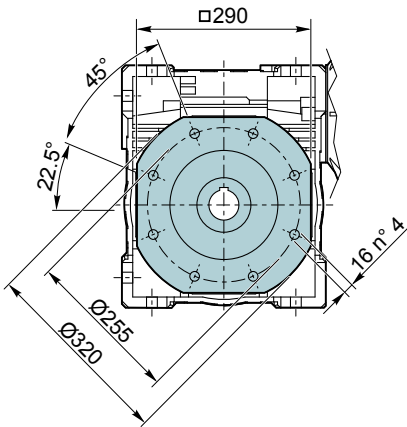

FA DX
Standard

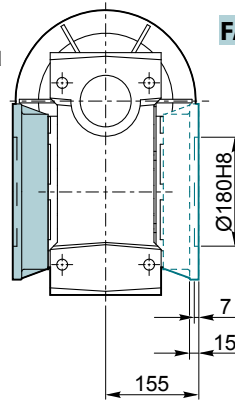

FA SX

VR 063 / 040 P...

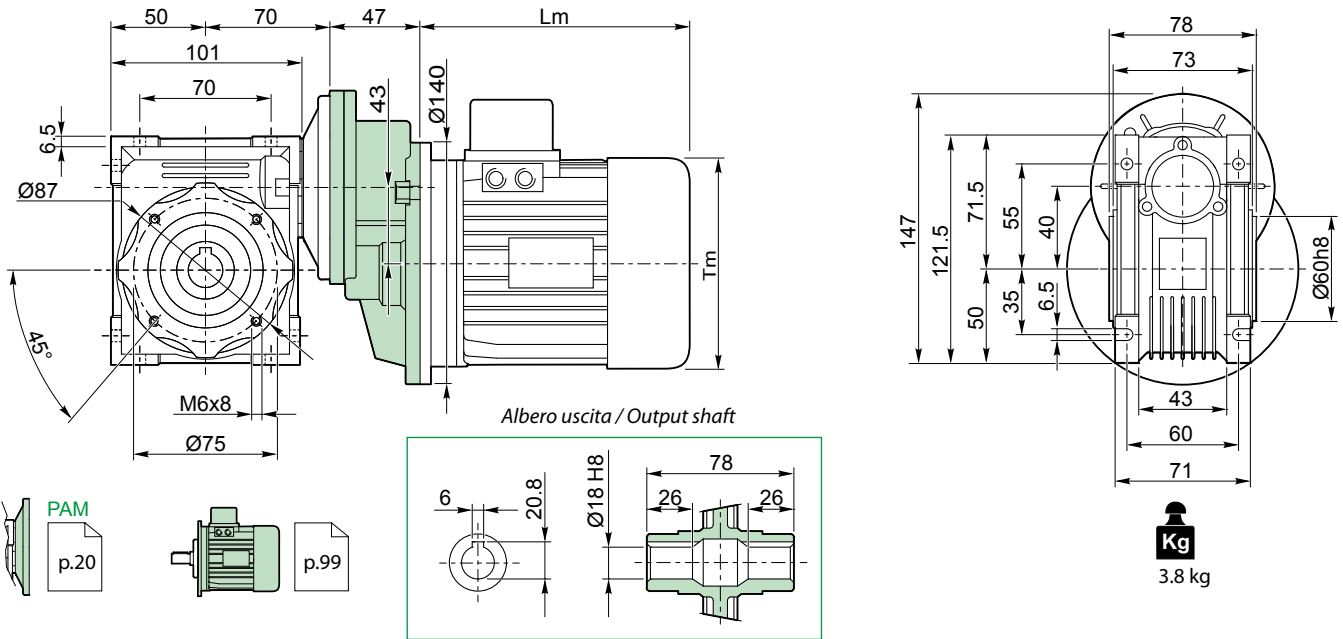

VR 063 / 040 F...

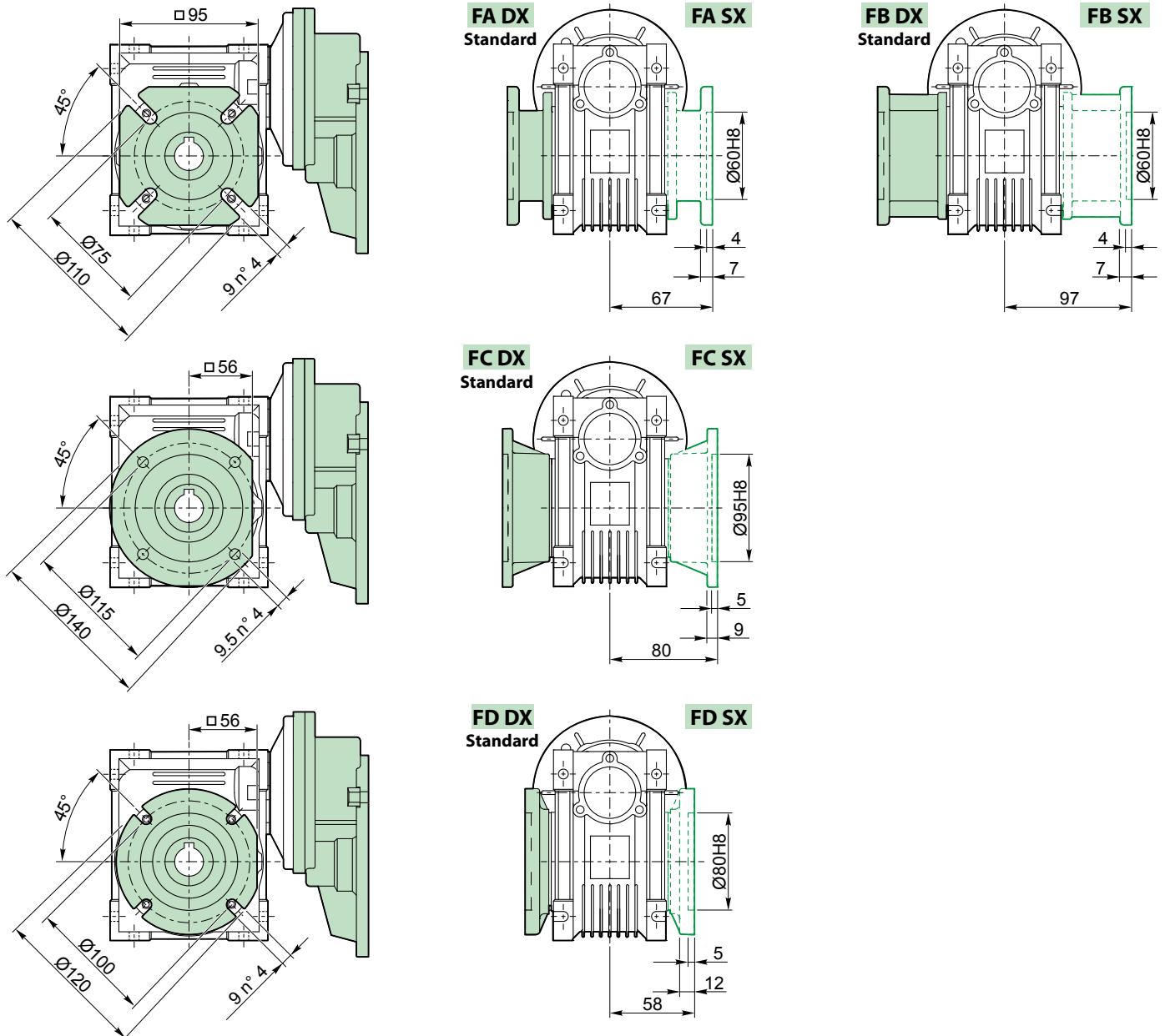

VR 063 / 050 P...

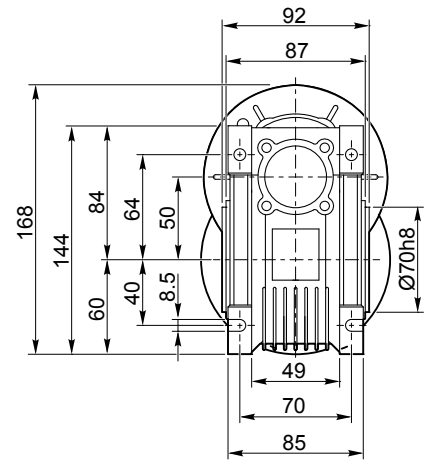
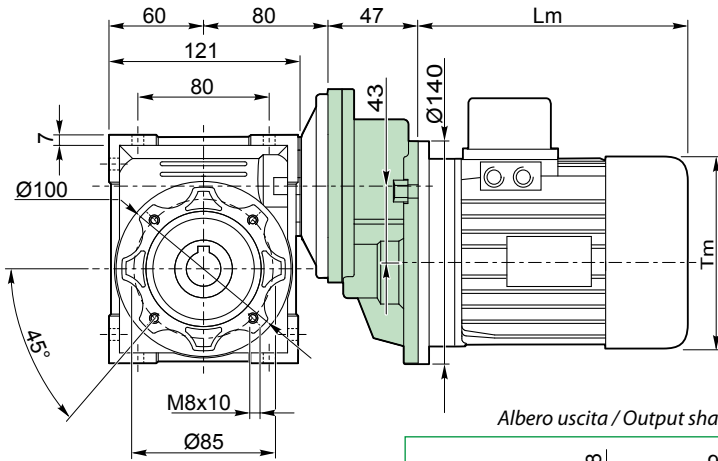

Albero uscita / Output shaft

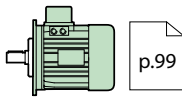
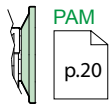
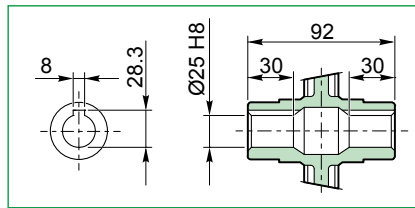

Kg
5 kg

VR 063 / 050 F...

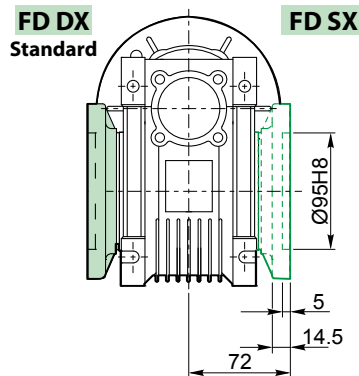
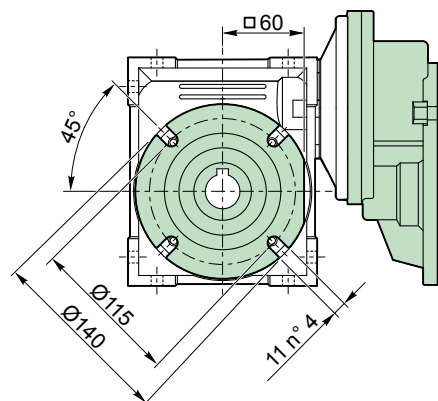
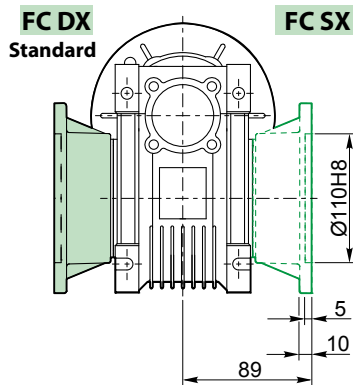
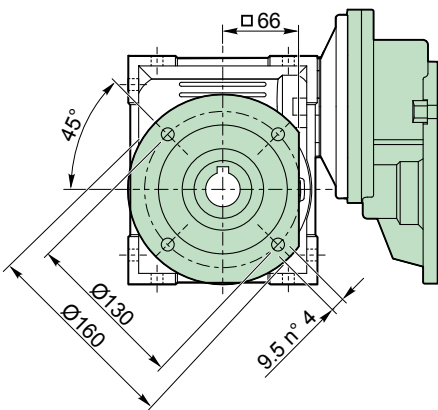
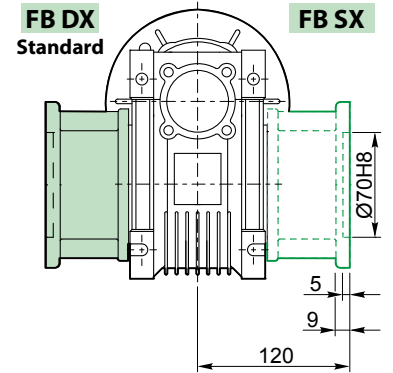
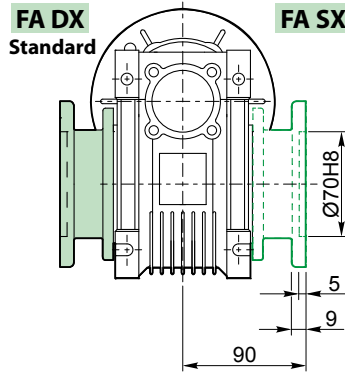
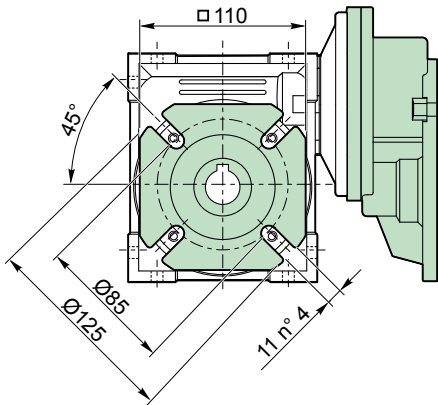

VR 071 / 050 P...

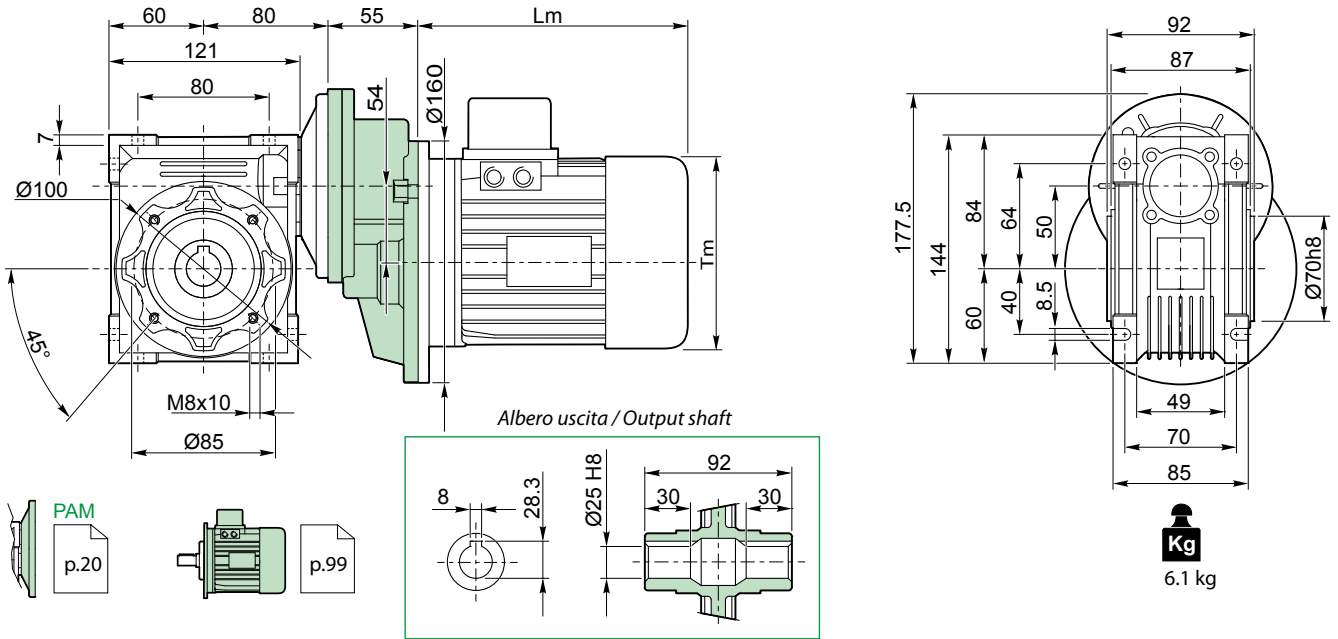

VR 071 / 050 F...

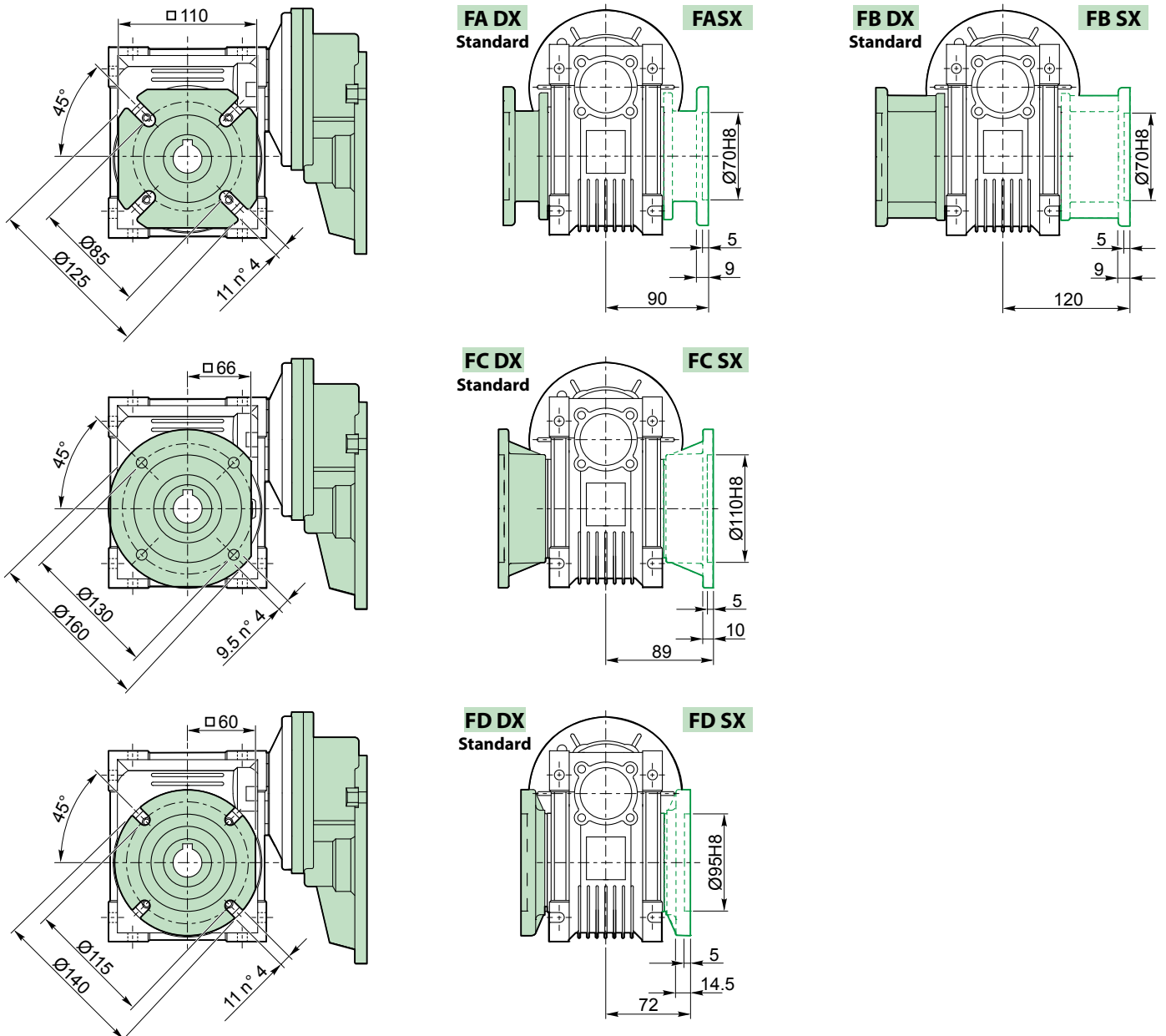

VR 071 / 063 P...

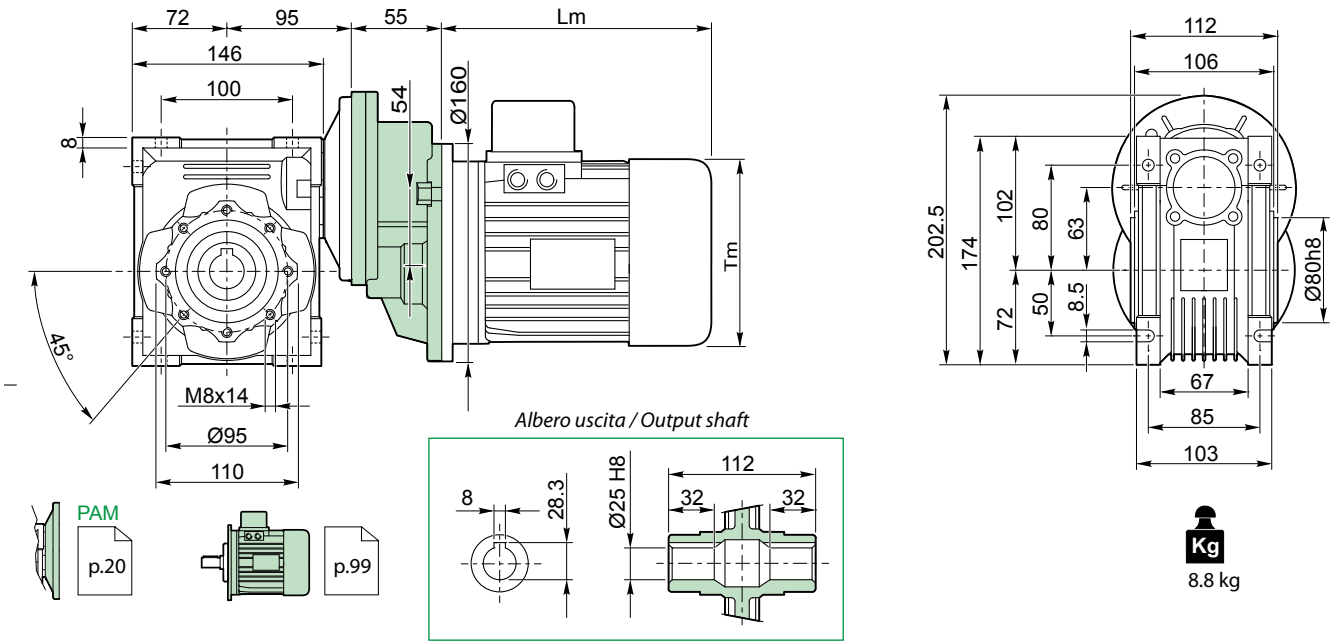

VR 071 / 063 F...

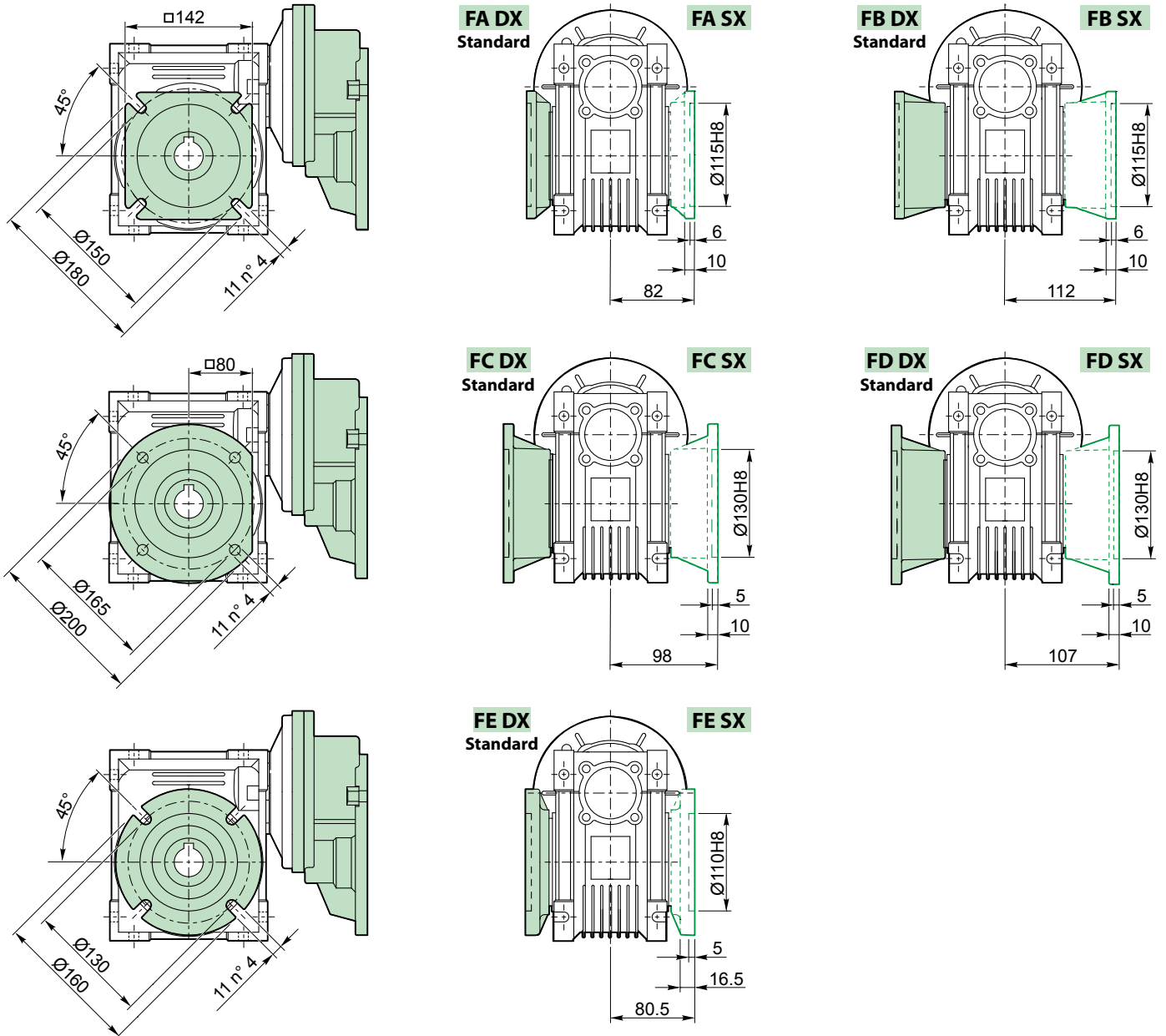

VR 071/075 P...

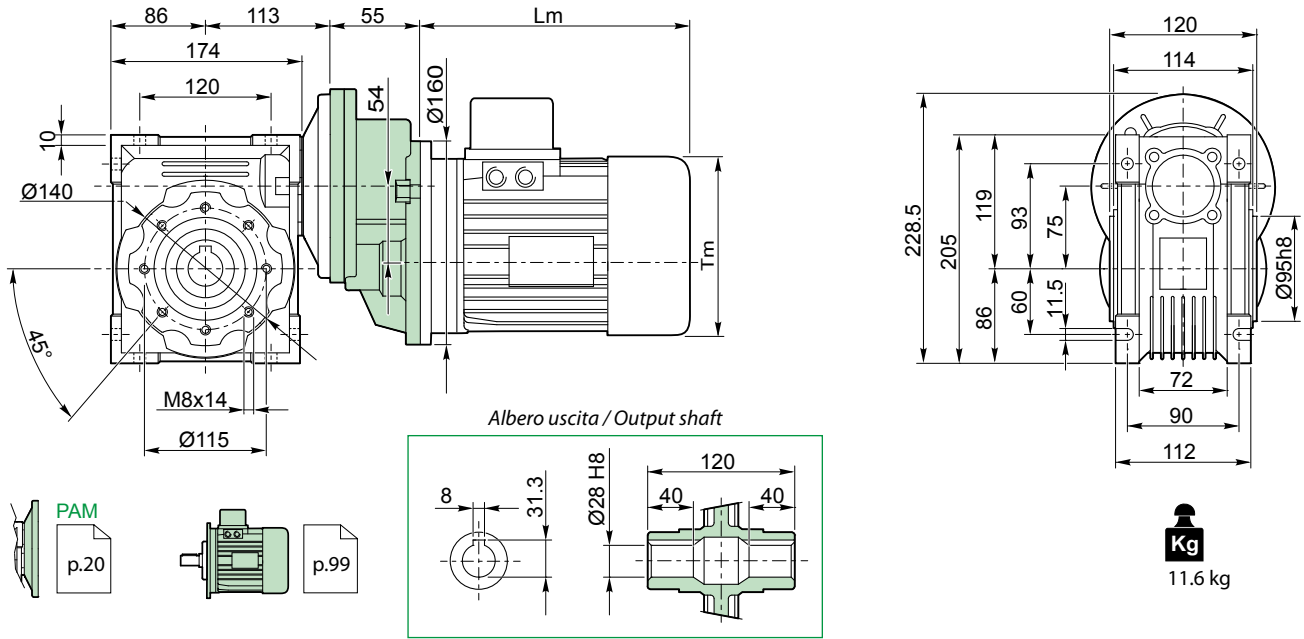

VR 071 / 075 F...

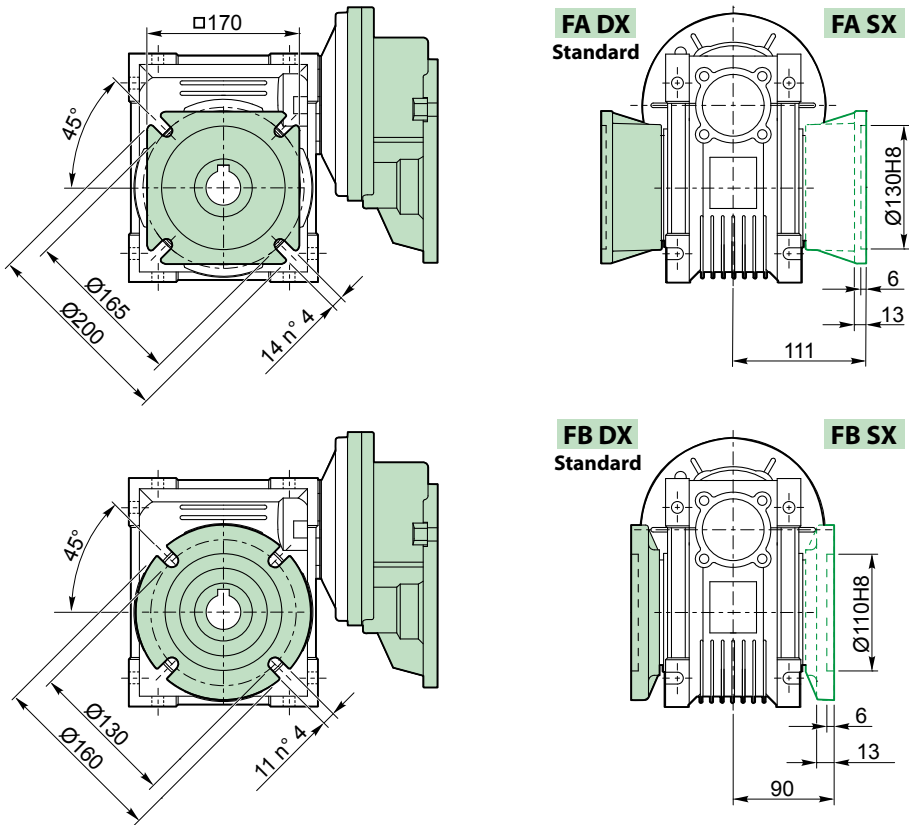

VR 080 / 075 P...

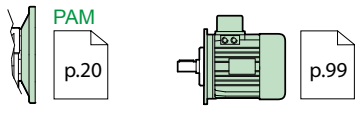
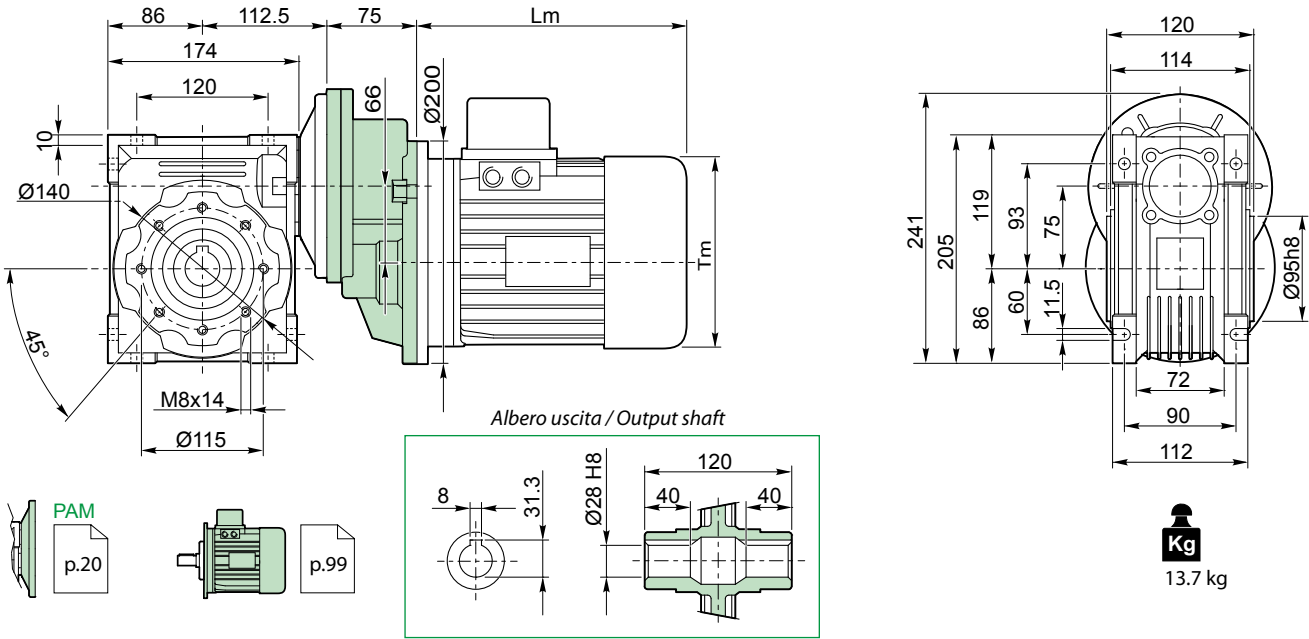

VR 080 / 075 F...

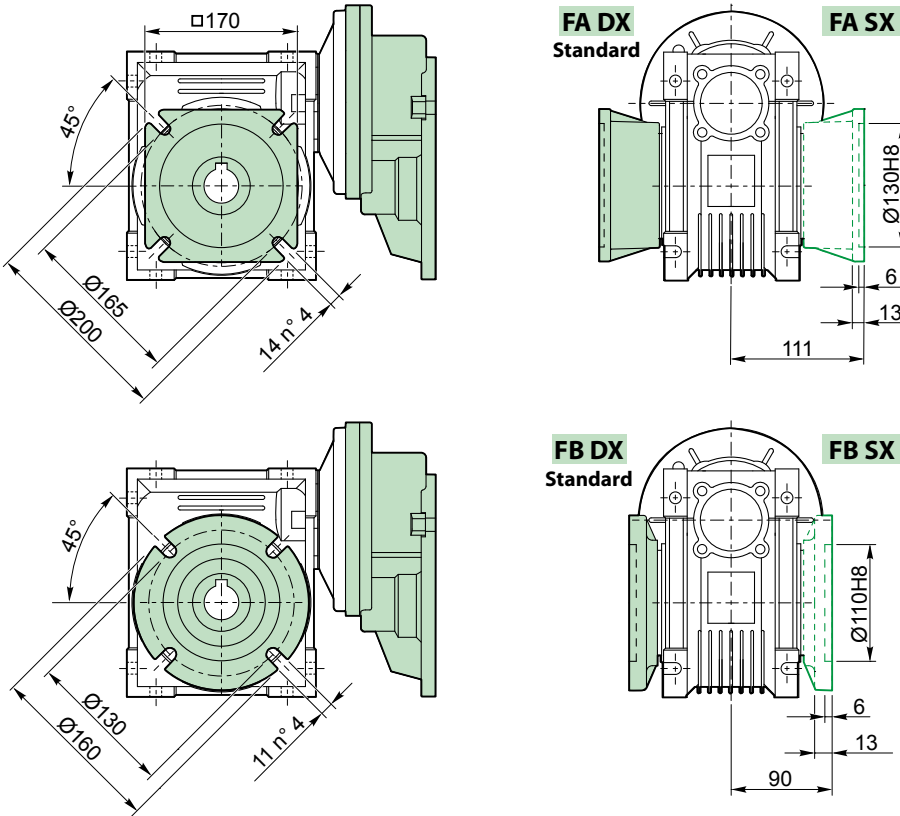

VR 080 / 090 P...

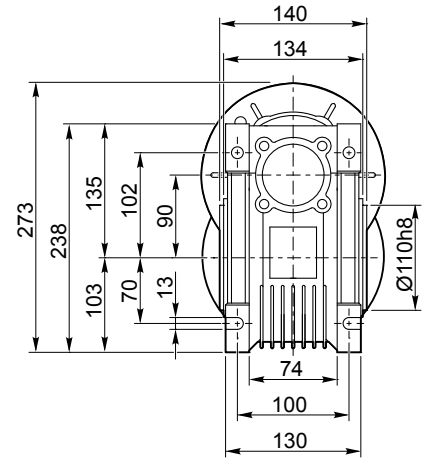
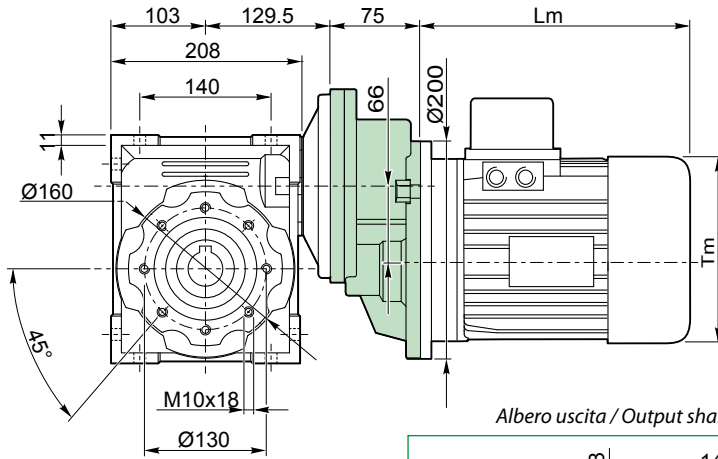

Albero uscita / Output shaft

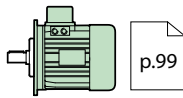
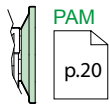
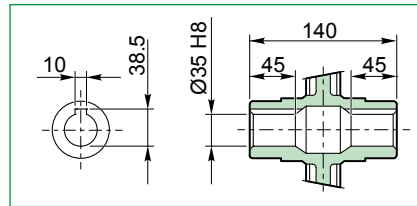

Kg
17.7 kg

VR 080 / 090 F...

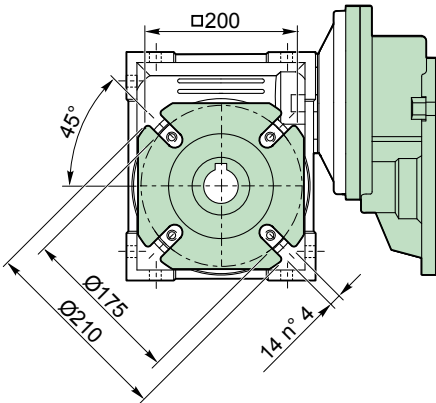

FA DX
Standard

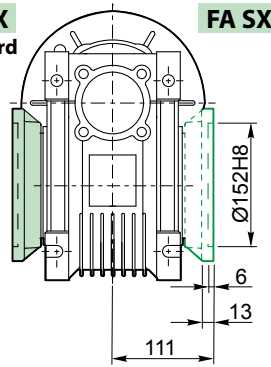

FA SX

FD DX
Standard

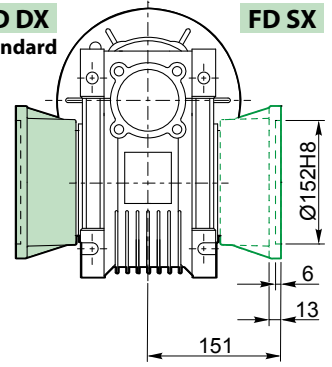

FD SX

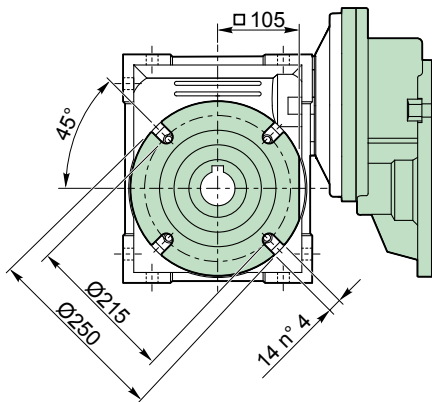

FB DX
Standard

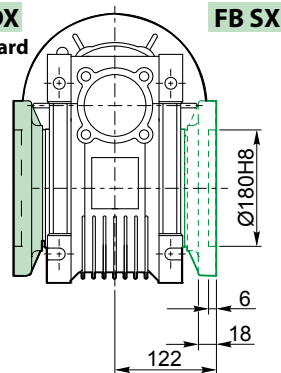

FB SX

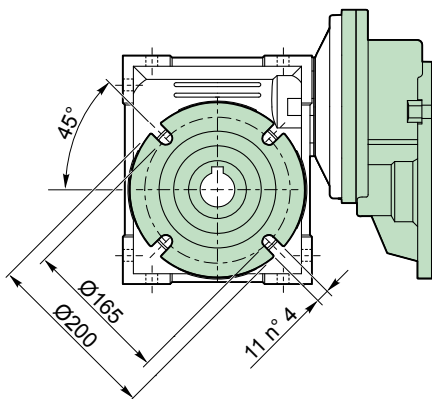

FC DX
Standard

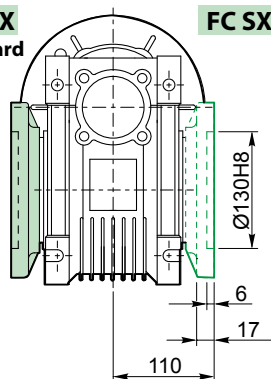

FC SX

VR 080 / 110 P...

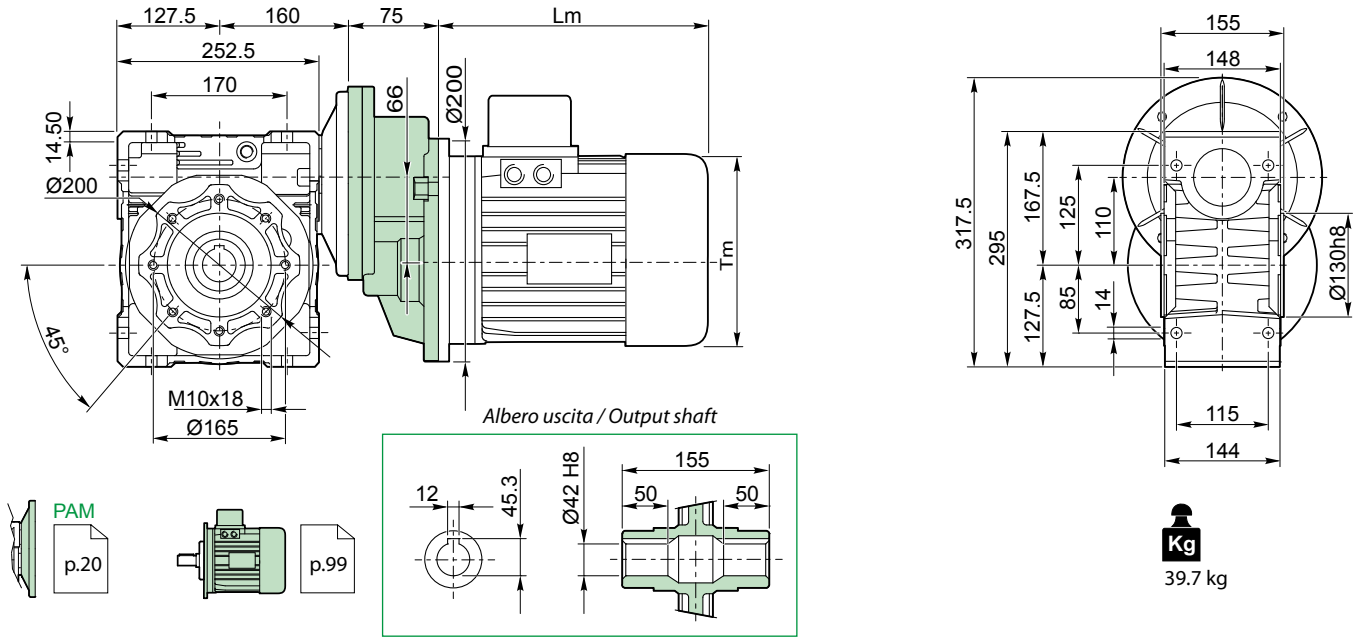

VR 080 / 110 F...

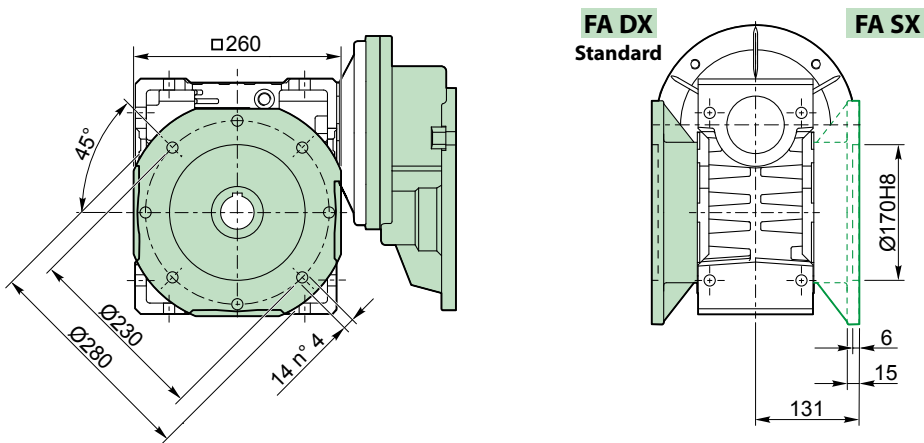

VR 090 / 075 P...

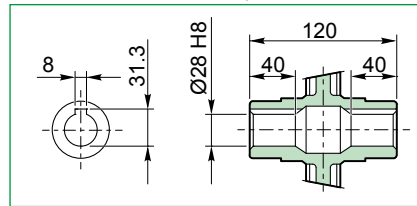
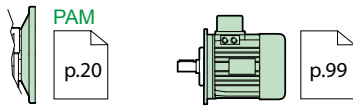
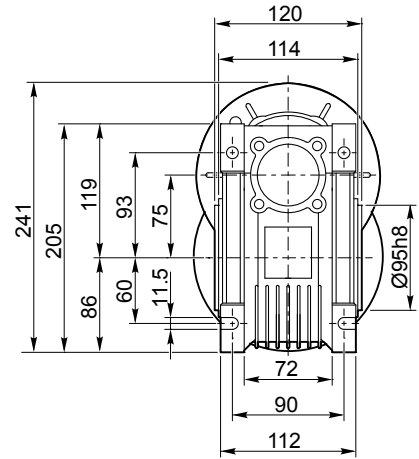
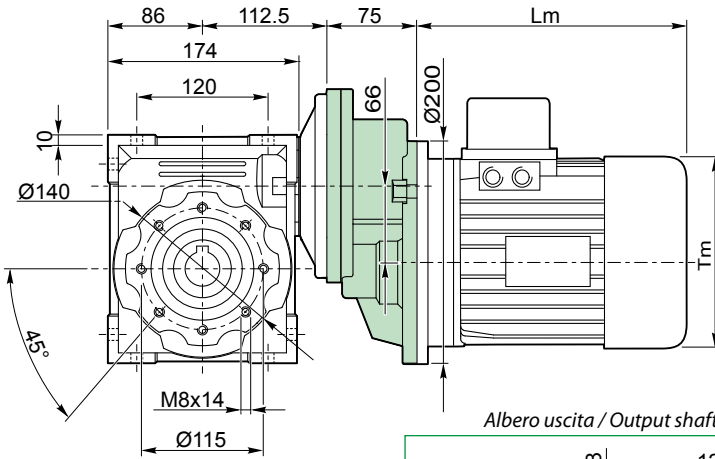

Kg
13.7 kg

VR 090 / 075 F...

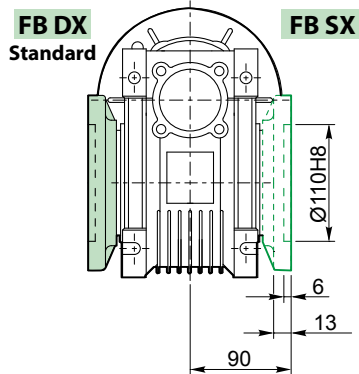
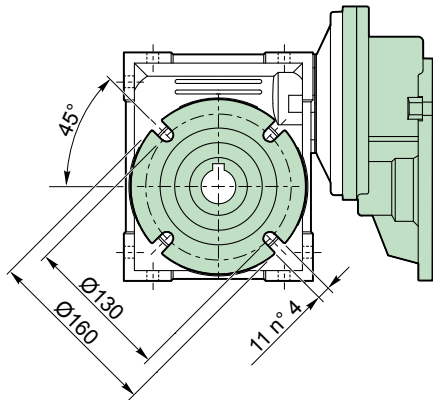
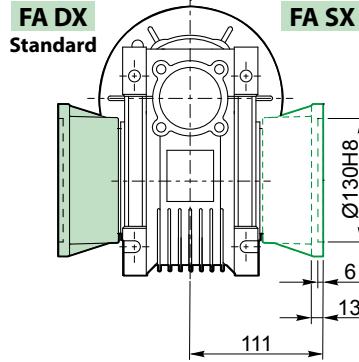
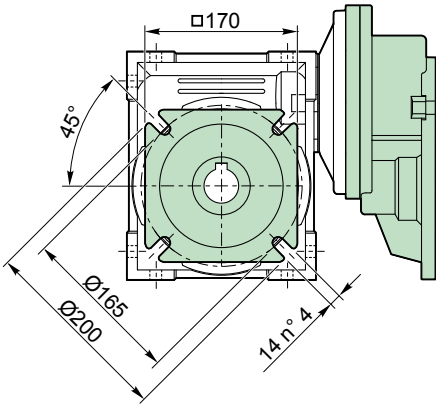

VR 090 / 090 P ...

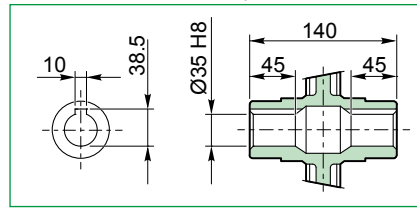
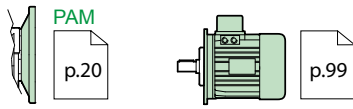
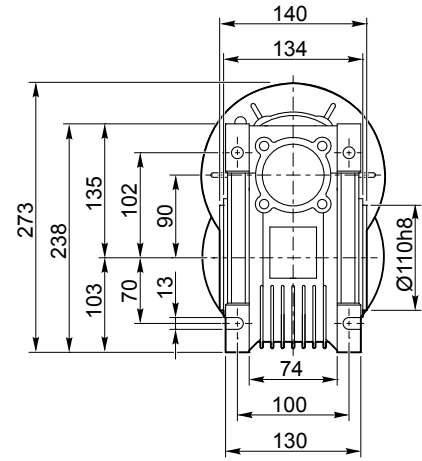
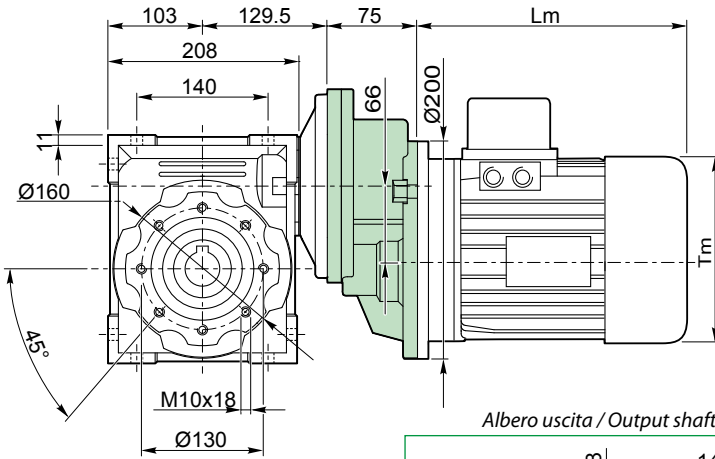

Kg
17.7 kg

VR 090 / 090 F...

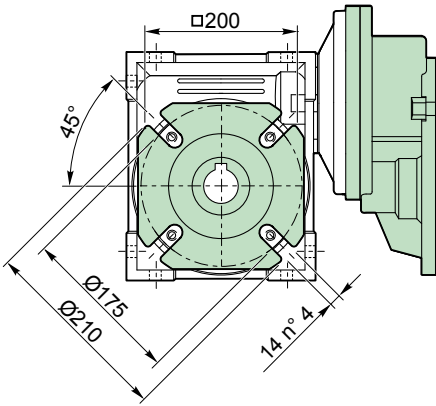

FA DX
Standard

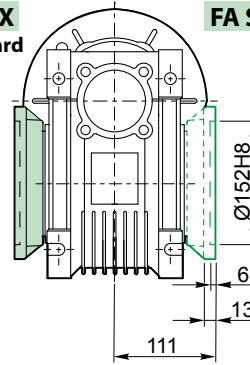

FD DX
Standard

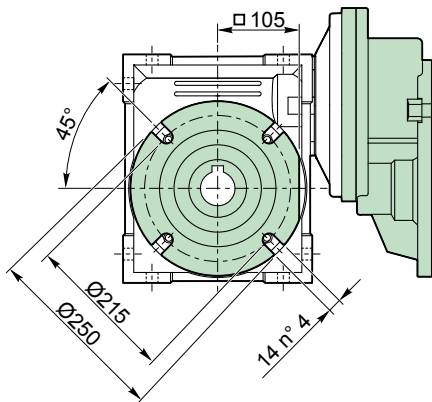
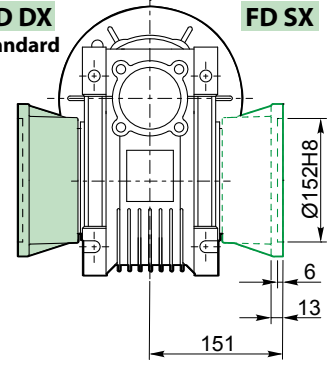

FB DX
Standard

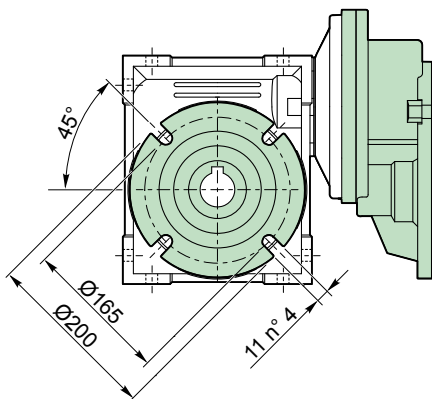
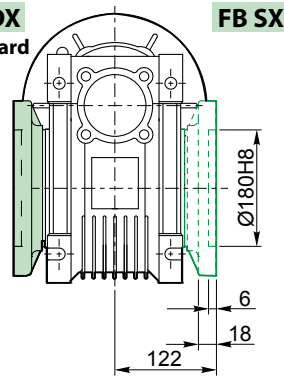

FC DX
Standard

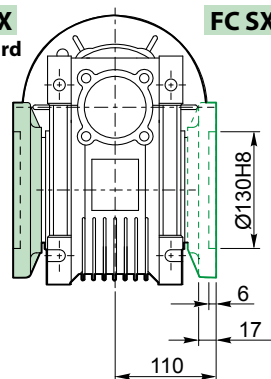

VR 090 / 110 P...

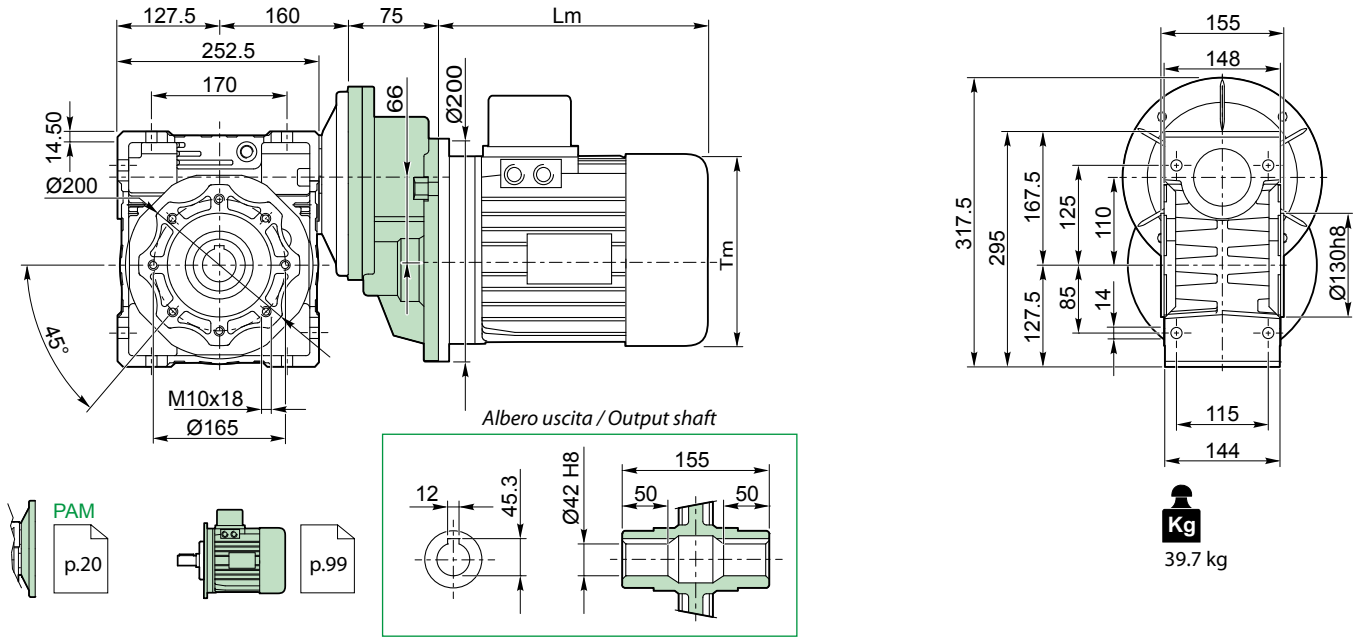

VR 090 / 110 F...

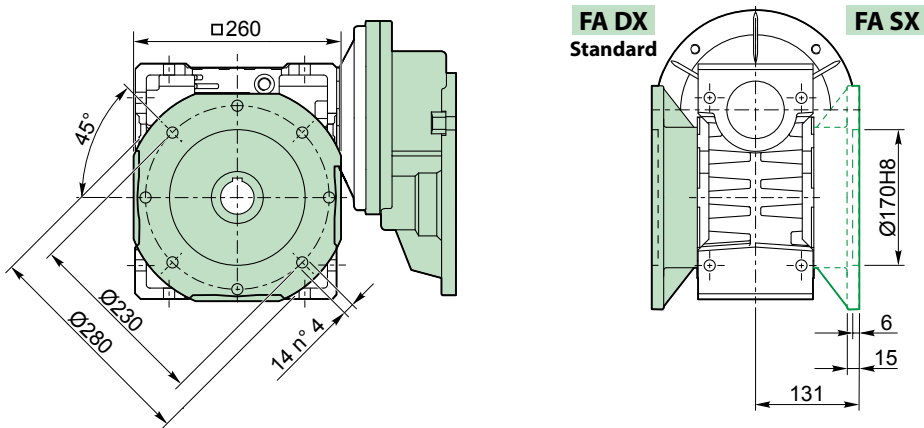

VR 090 / 130 P ...

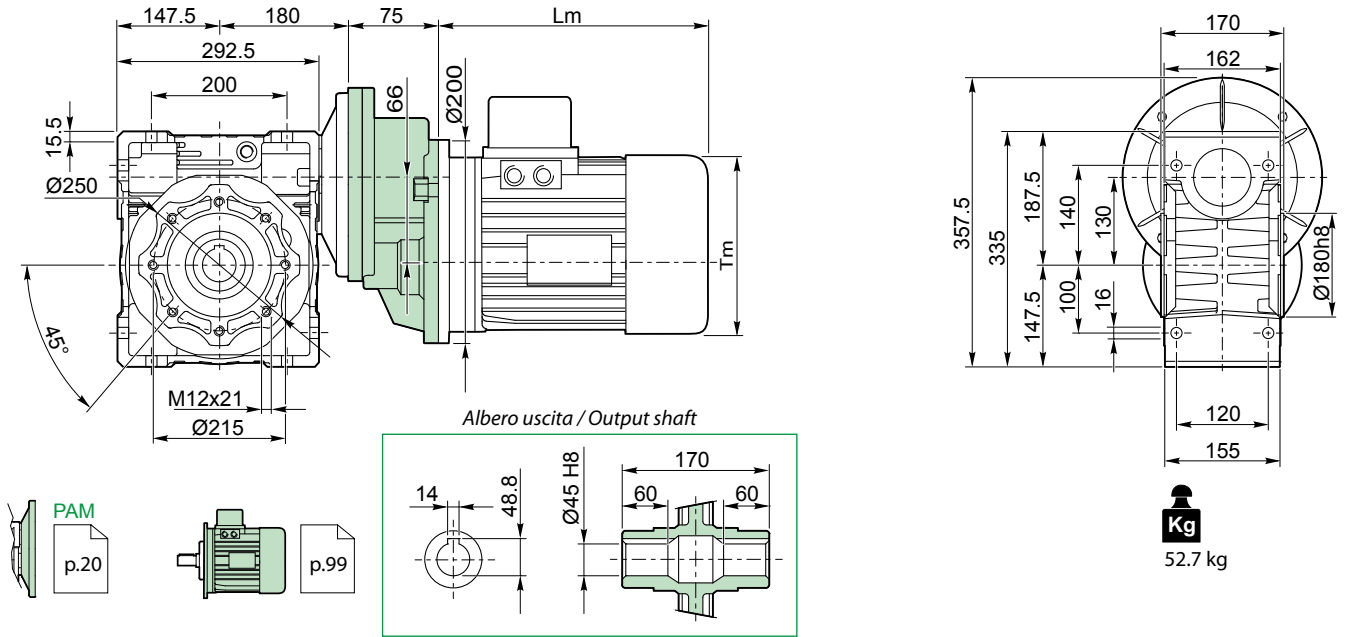

VR 090 / 130 F...

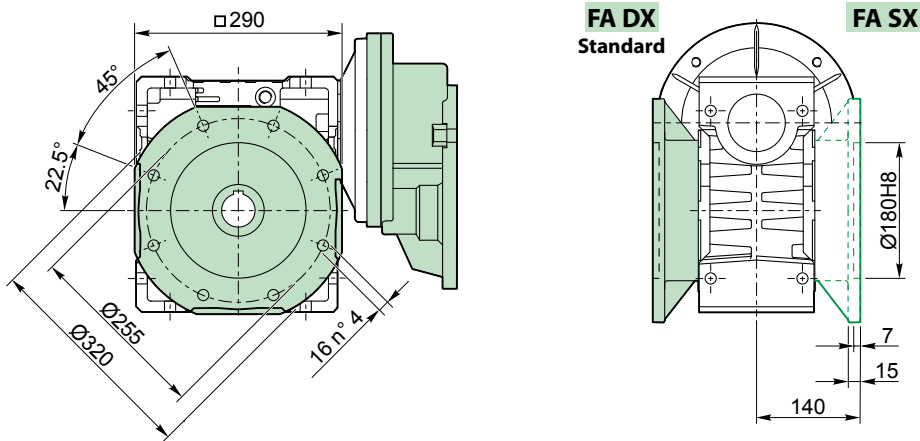

VC 025 / 030 P...

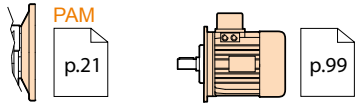
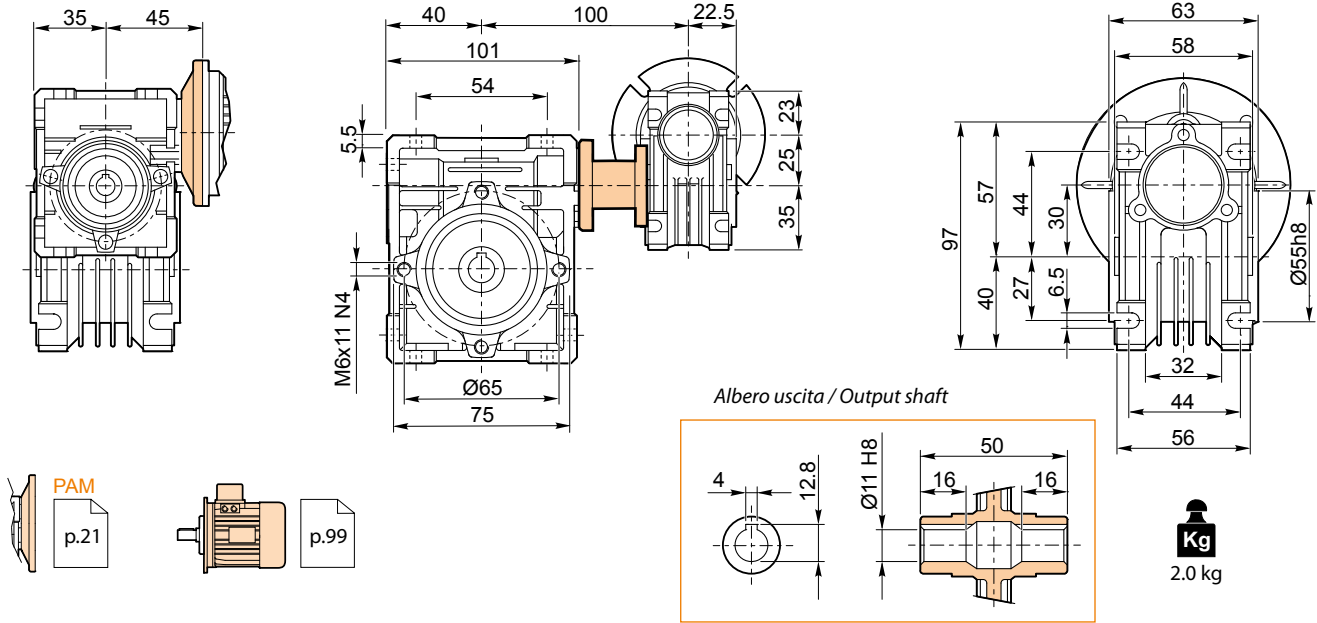

VC 025 / 030 F...

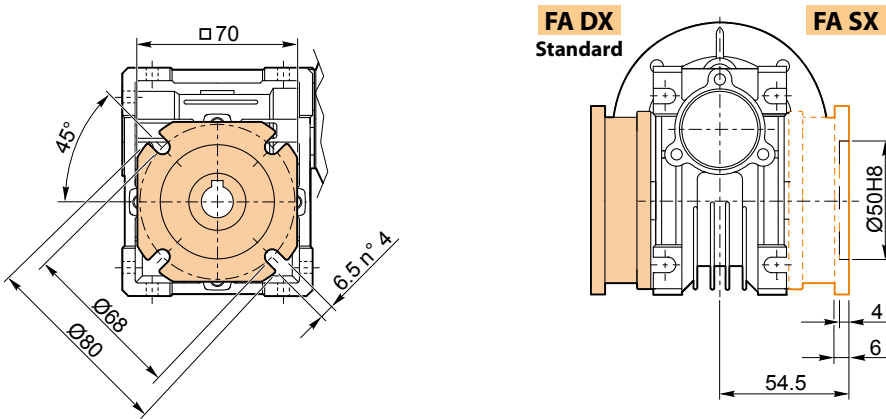

VC 025 / 040 P...

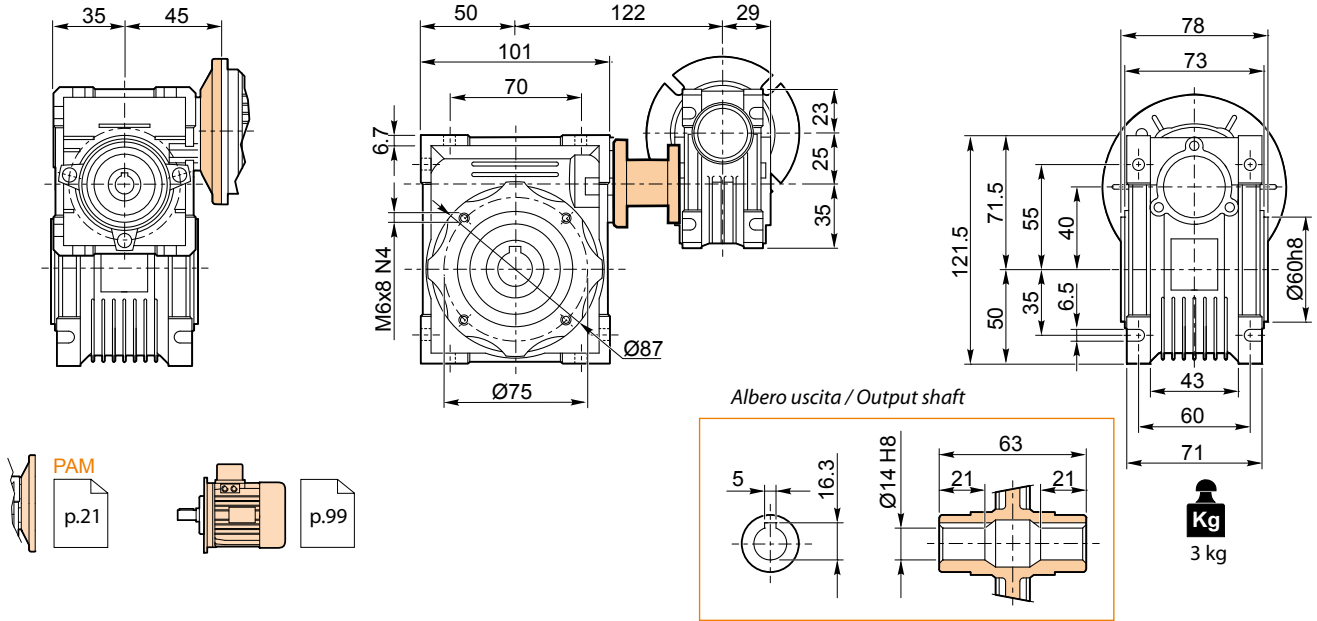

VC 025 / 040 F...

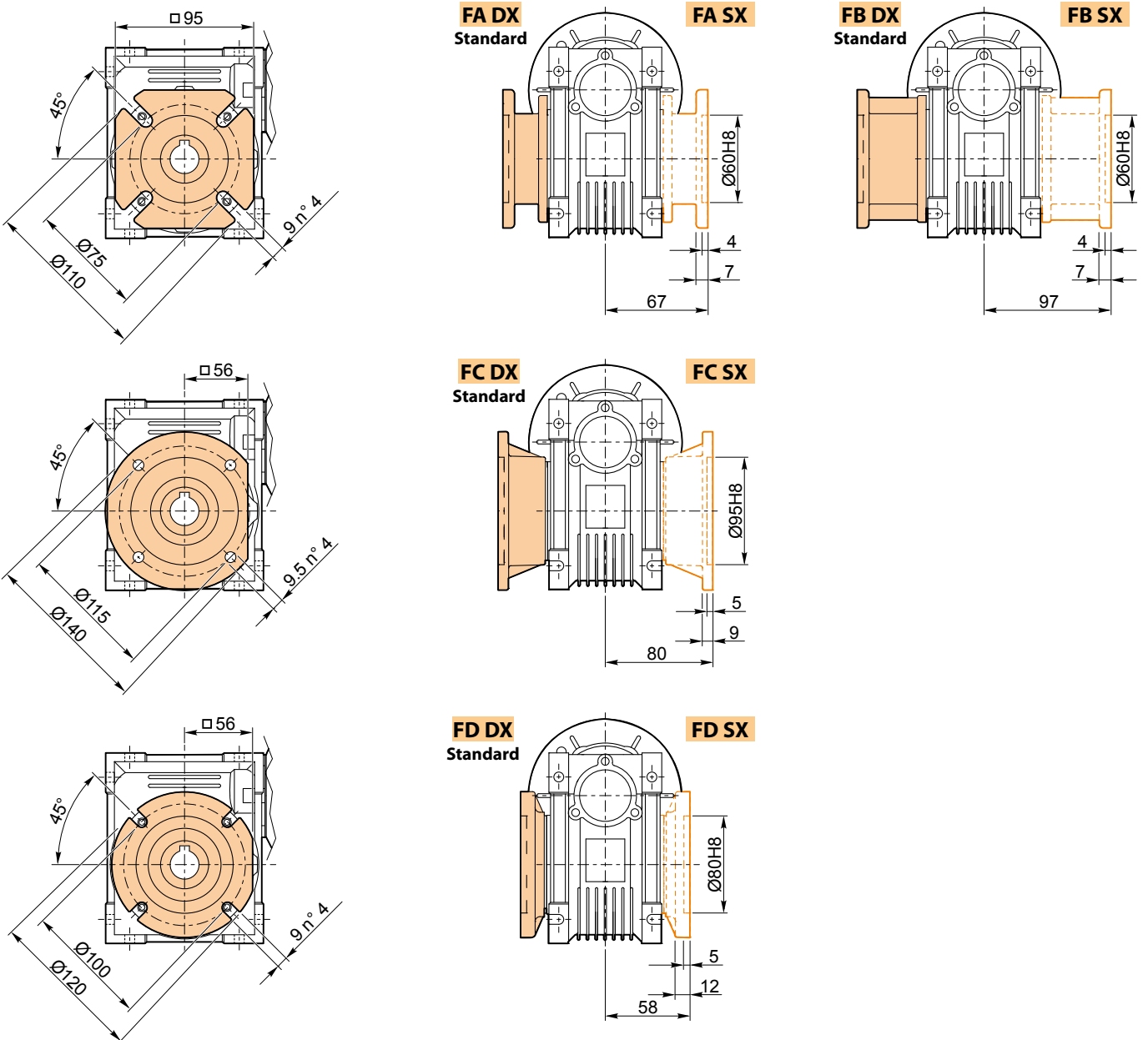

VC 030 / 040 P ...

VS 030 / 040 P ...

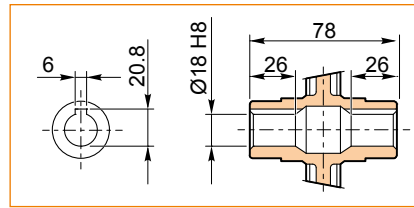
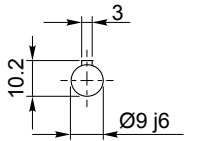
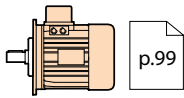
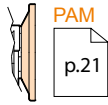
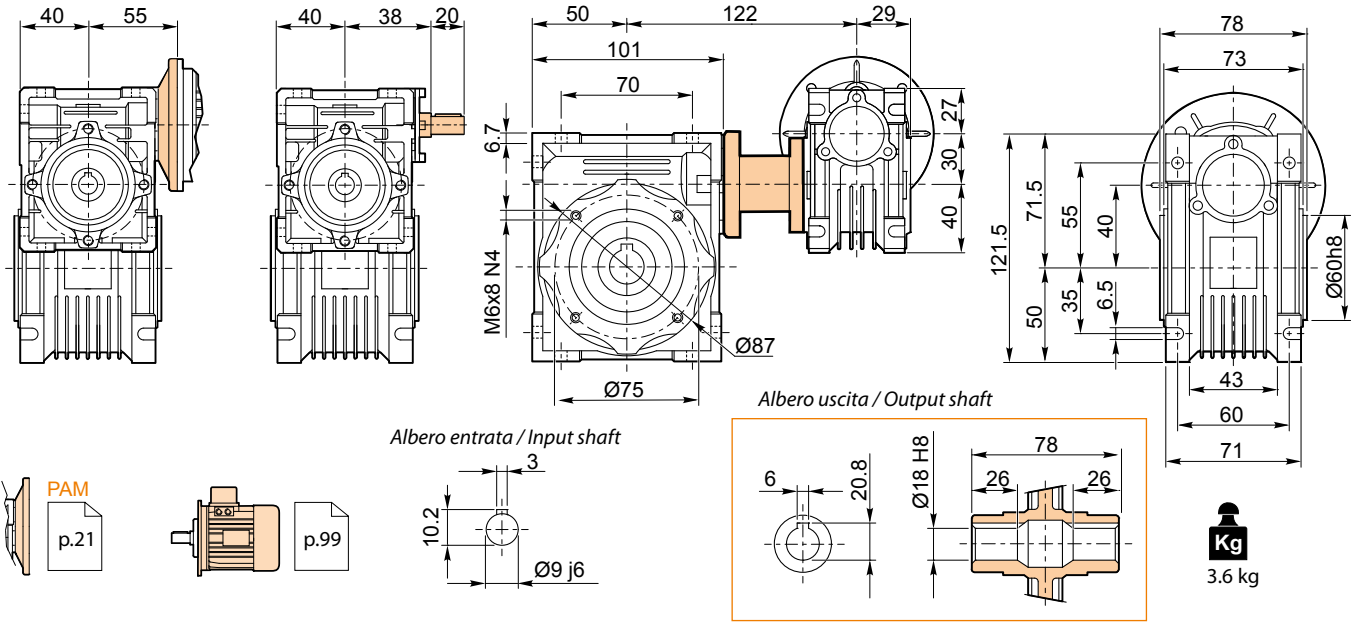

VC 030 / 040 F...

VS 030 / 040 F...

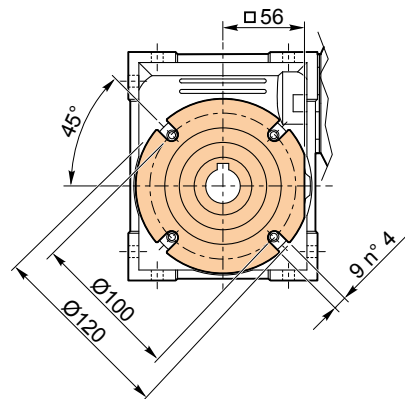
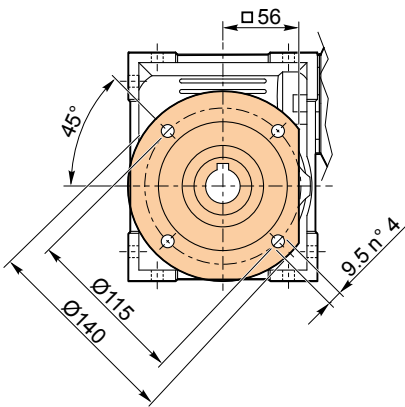
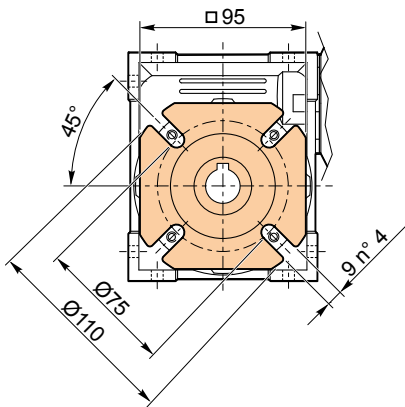

FA DX Standard

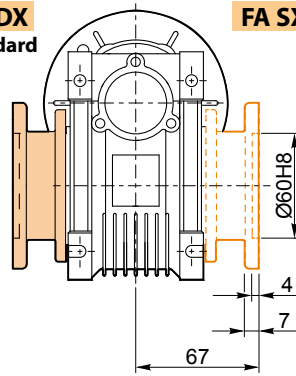

FA SX

FB DX Standard

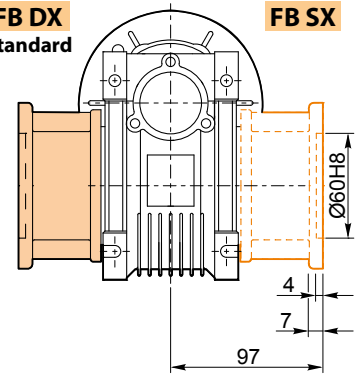

FB SX

FC DX Standard

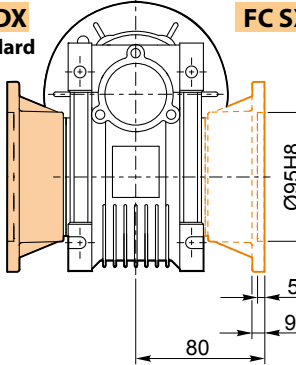

FC SX

FD DX Standard

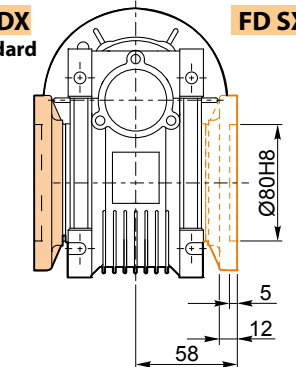

FD SX

VC 030/050 P...

VS 030/050 P...

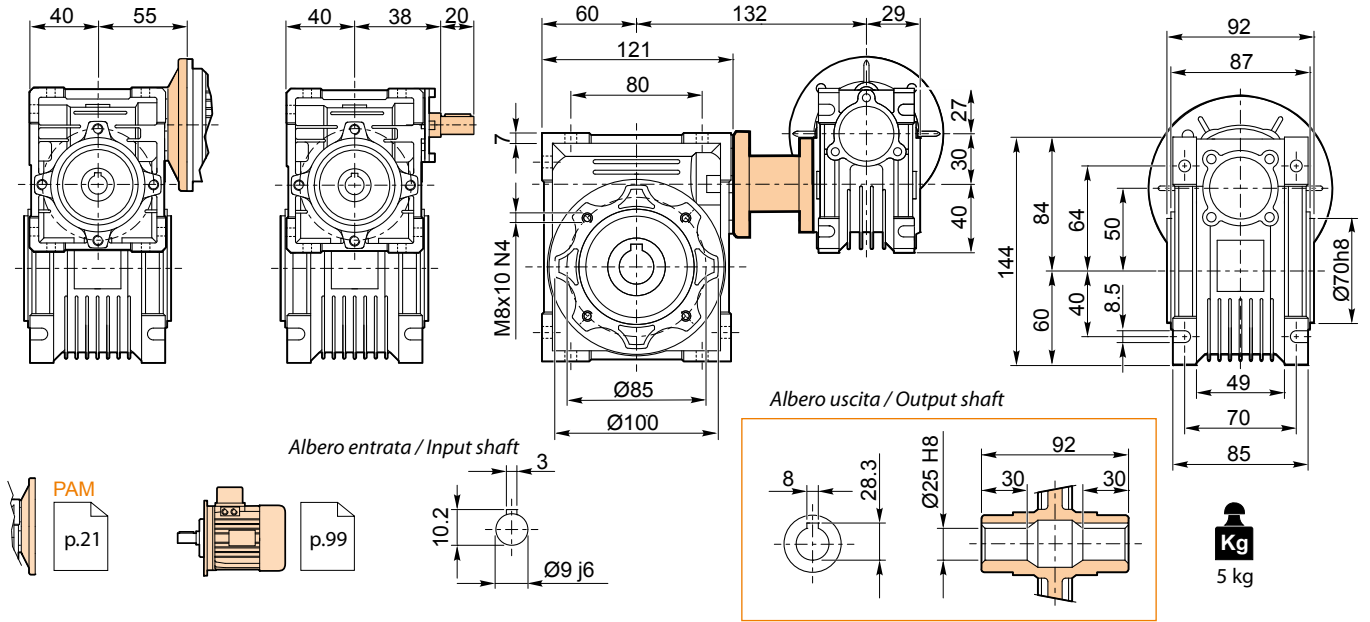

VC 030 / 050 F...

VS 030 / 050 F...

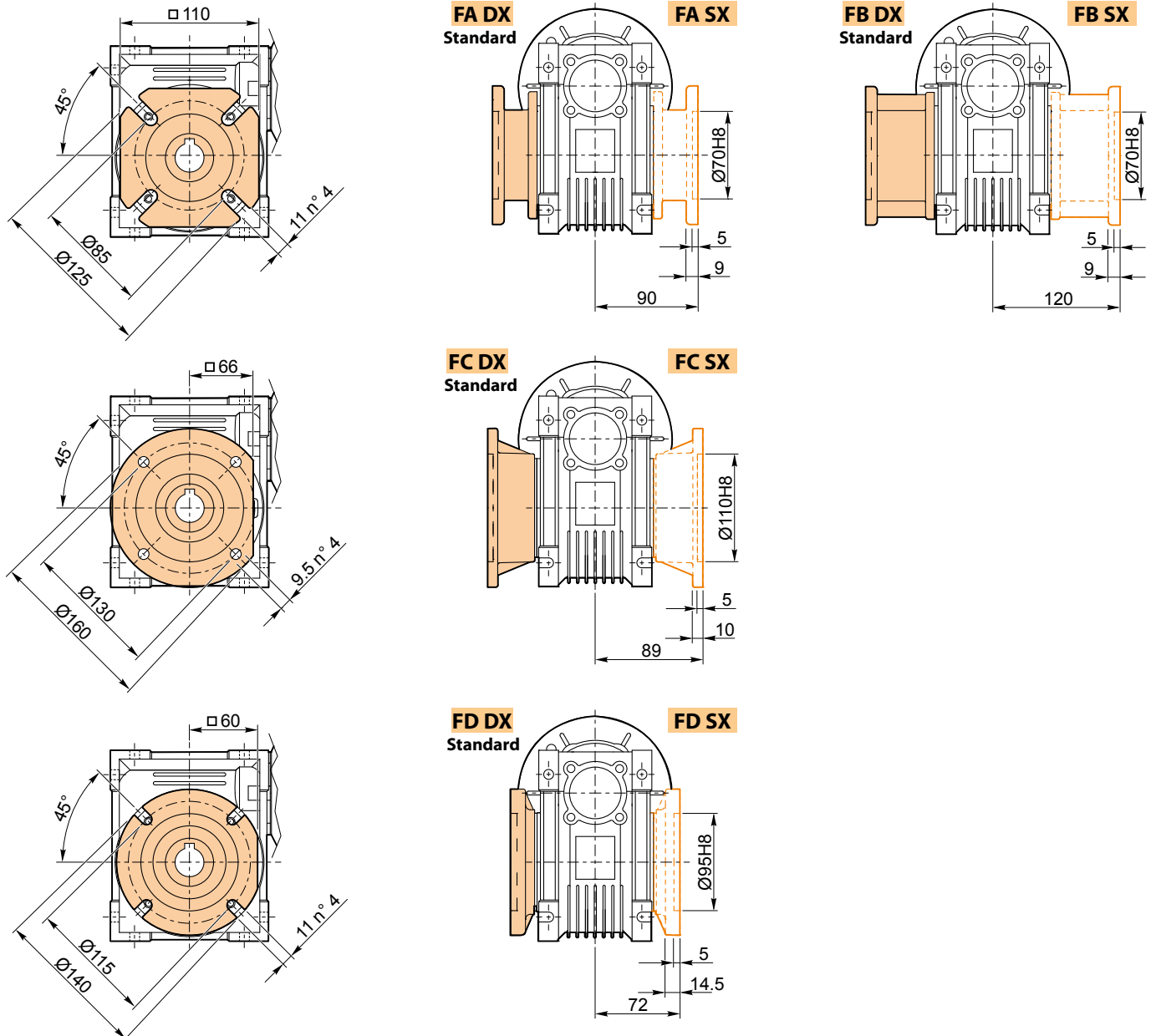

VC 030/063 P ...

VS 030/063 P ...

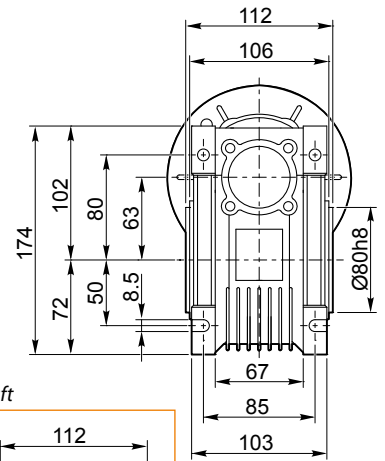
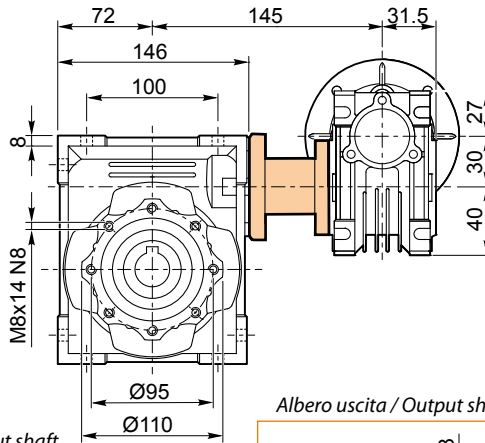
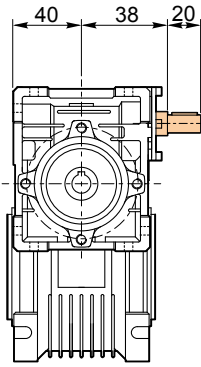
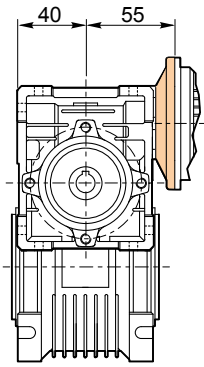

Albero entrata / Input shaft

Albero uscita / Output shaft

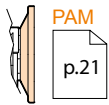

PAM
p.21

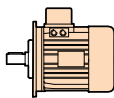

p.99

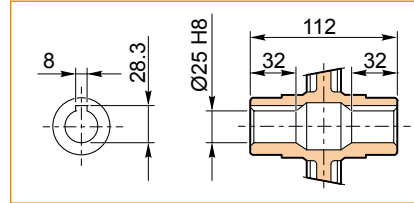
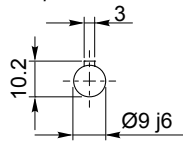

Kg
7.5 kg

VC 030 / 063 F...

VS 030 / 063 F...

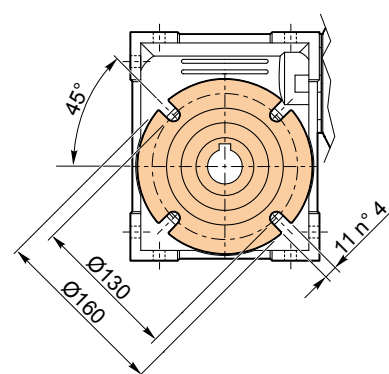
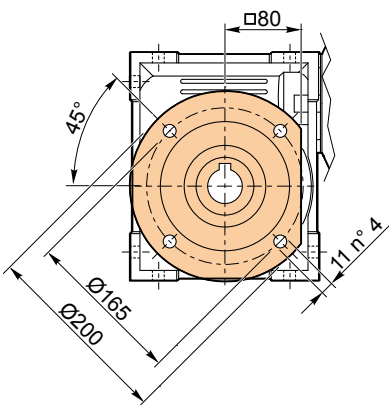
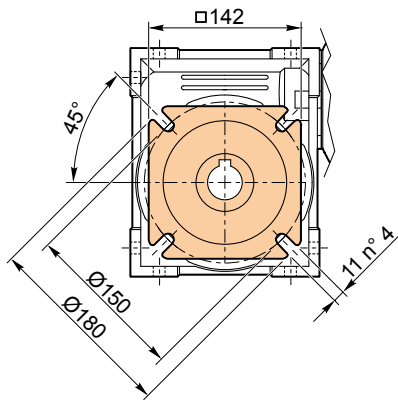

FA DX
Standard

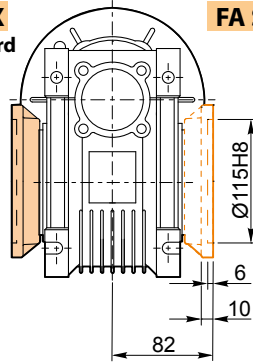

FA SX

FB DX
Standard

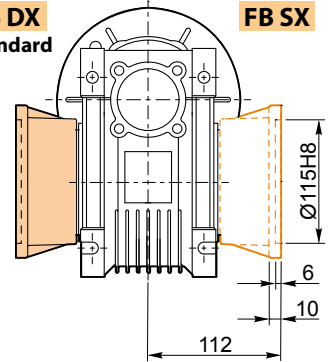

FB SX

FC DX
Standard

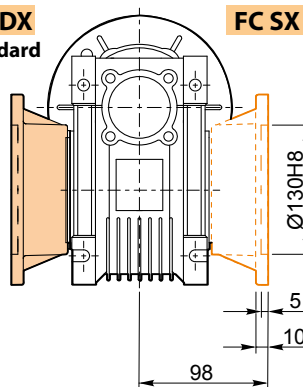

FC SX

FD DX
Standard

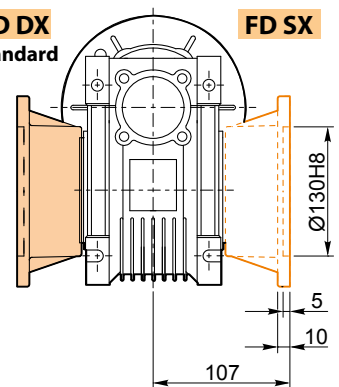

FD SX

FE DX
Standard

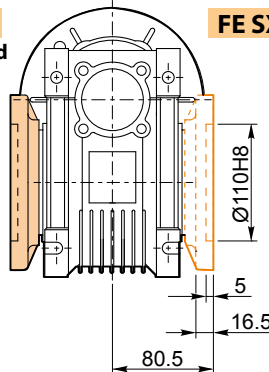

FE SX

VC 040/075 P...

VS 040/075 P...

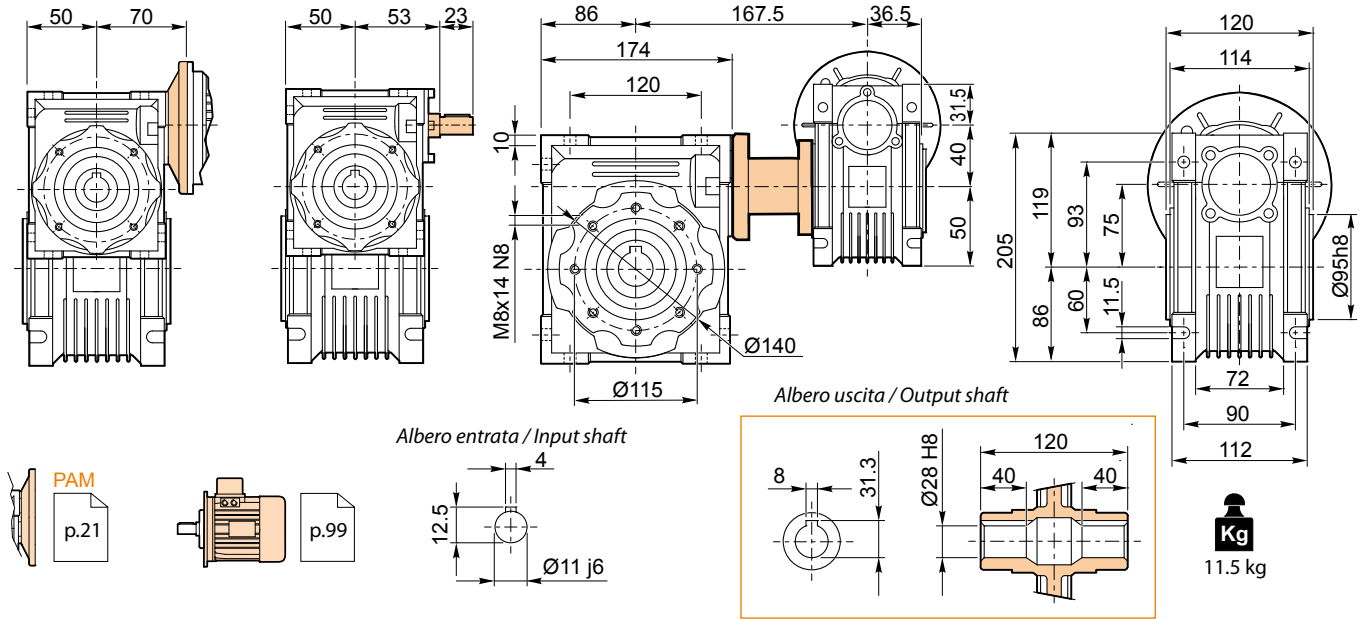

VC 040 / 075 F...

VS 040 / 075 F...

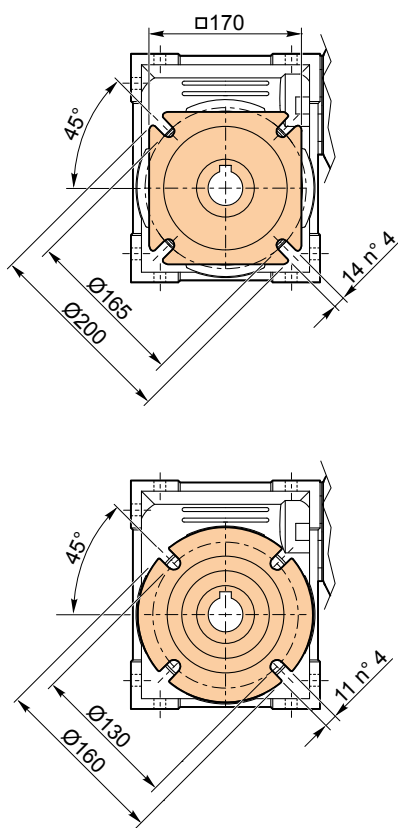

FA DX
Standard

FA SX

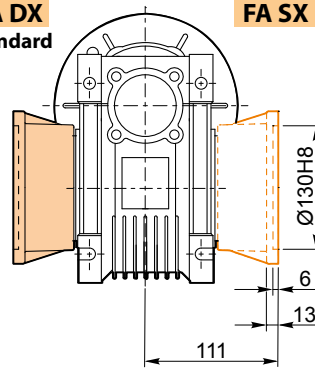

FB DX
Standard

FB SX

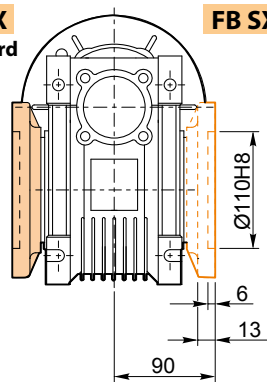

VC 040/090 P...

VS 040/090 P...

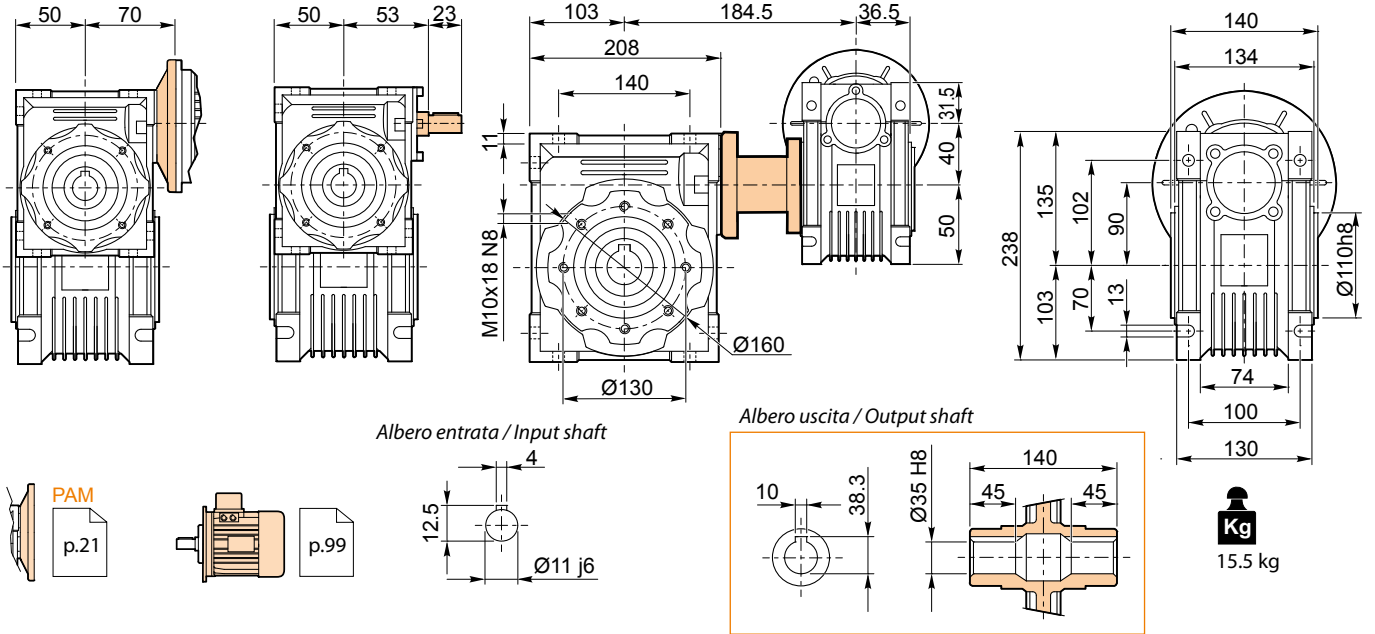

VC 040/090 F...

VS 040/090 F...

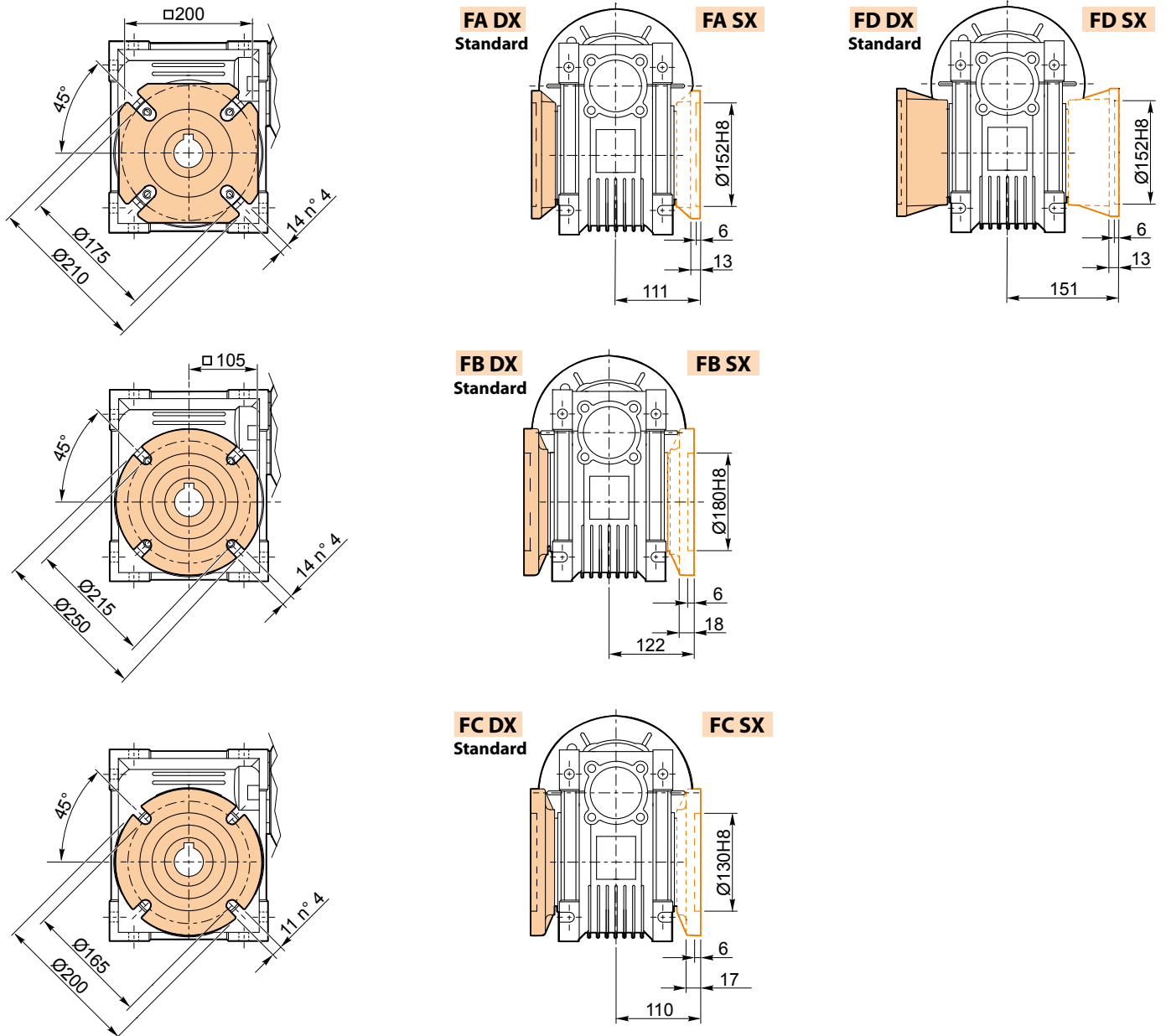

VC 050/110 P...

VS 050/110 P...

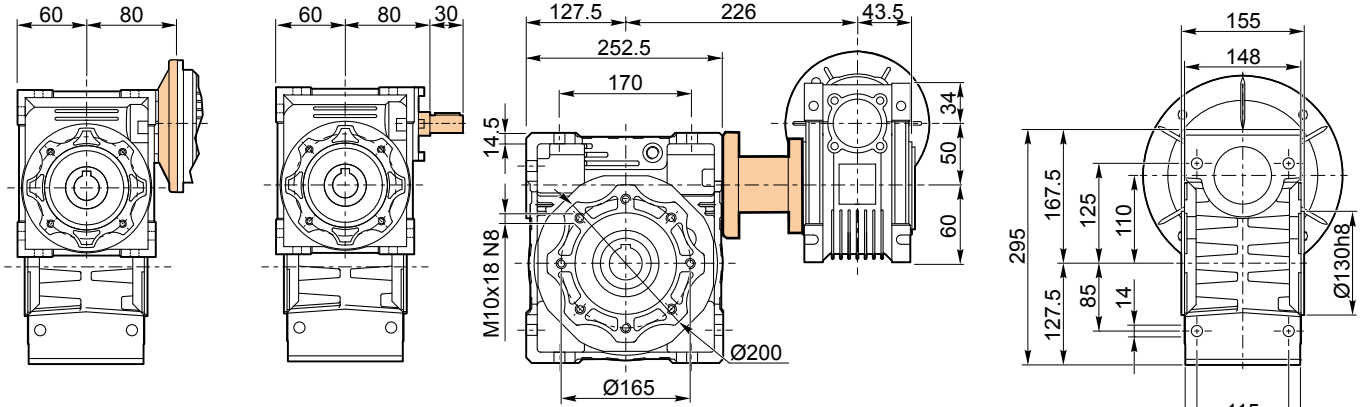

Albero entrata / Input shaft

Albero uscita / Output shaft

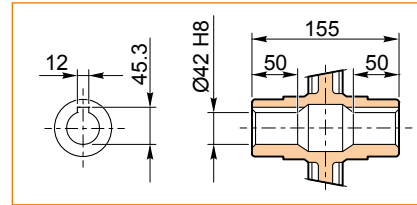
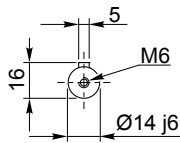
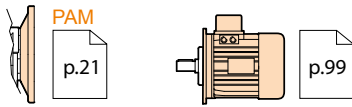

Kg
39 kg

VC 050/110 F...

VS 050/110 F...

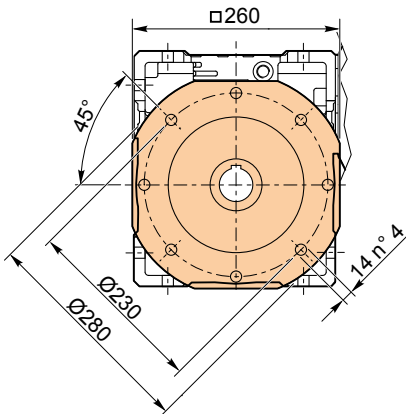

FA DX
Standard

FA SX

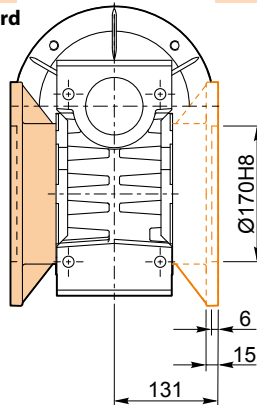

VC 063 / 130 P ...

VS 063 / 130 P ...

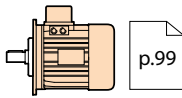
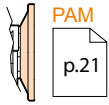
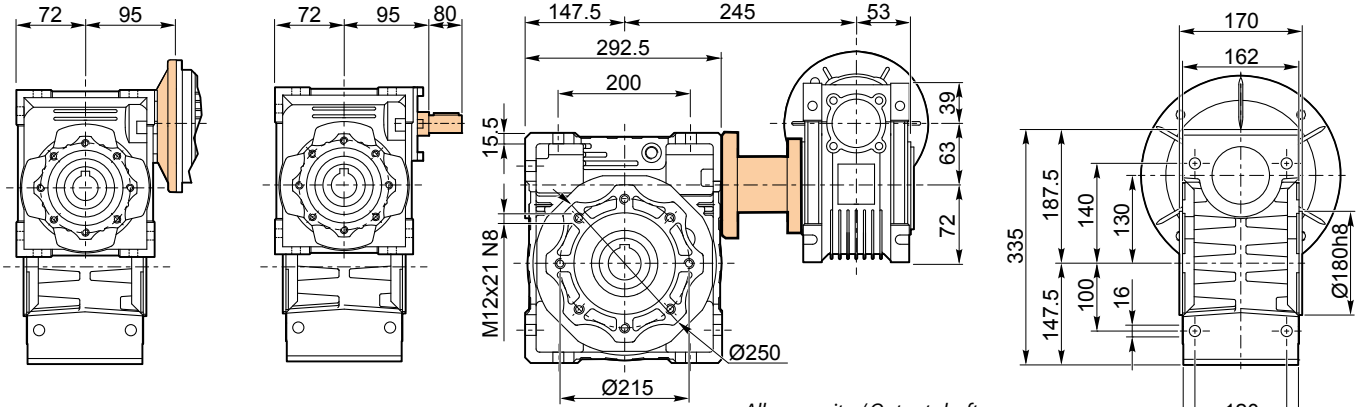

Albero entrata / Input shaft

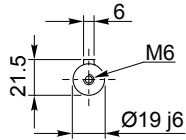

Albero uscita / Output shaft

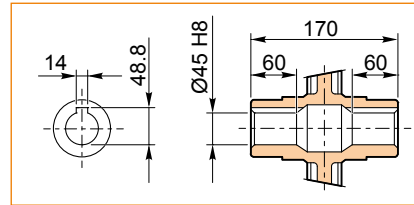

Kg
55 kg

VC 063 / 130 F...

VS 063 / 130 F...

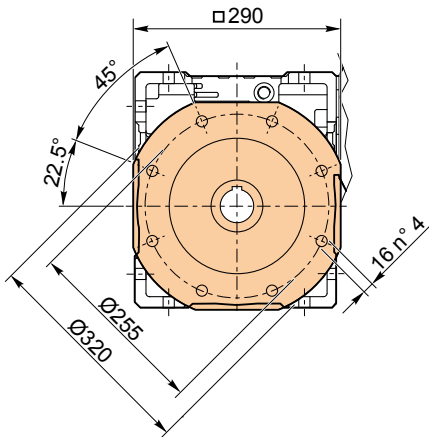

FA DX
Standard

FA SX

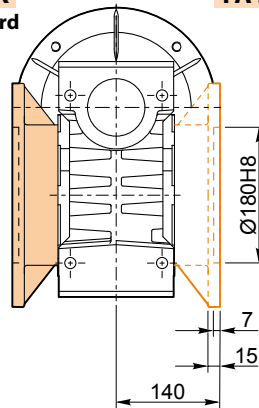

VC 063/ 150 P ...

VS 063/ 150 P ...

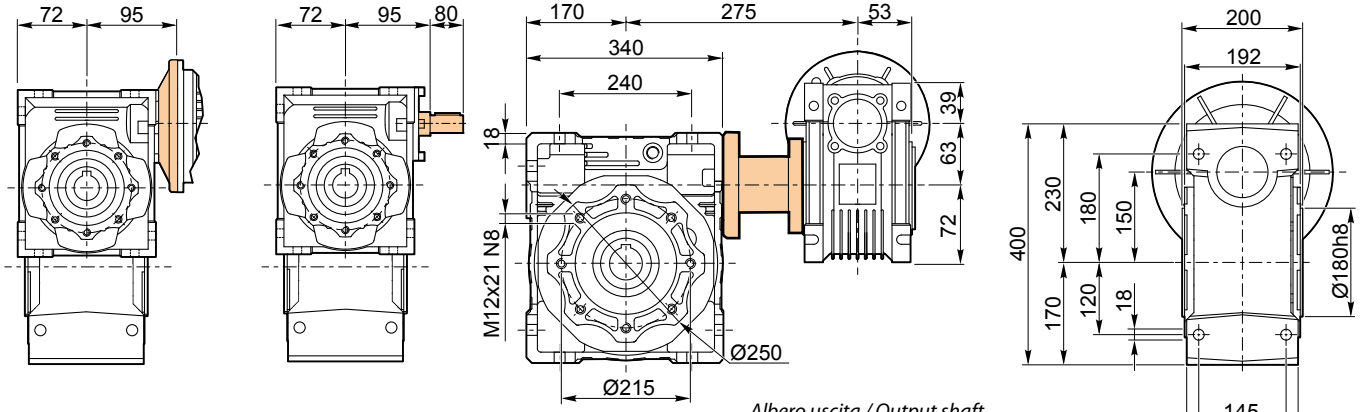

Albero uscita / Output shaft

Albero entrata / Input shaft

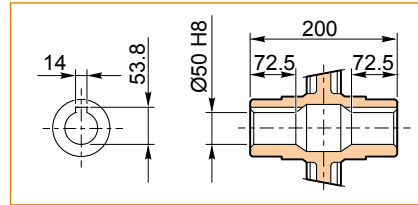
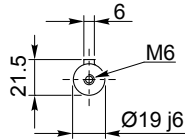
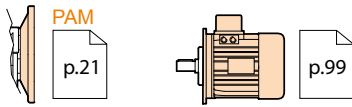

Kg
92 kg

VC 063 / 150F...

VS 063 / 150 F...

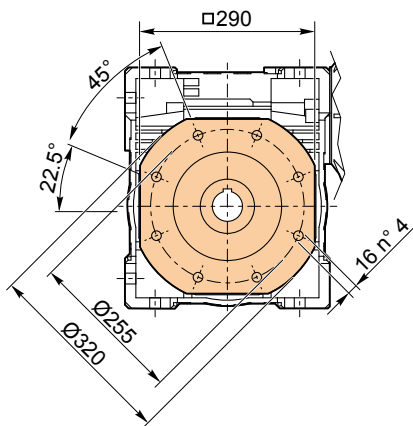

FA DX
Standard

FA SX

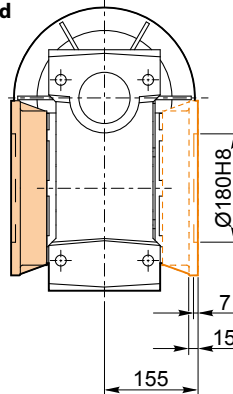

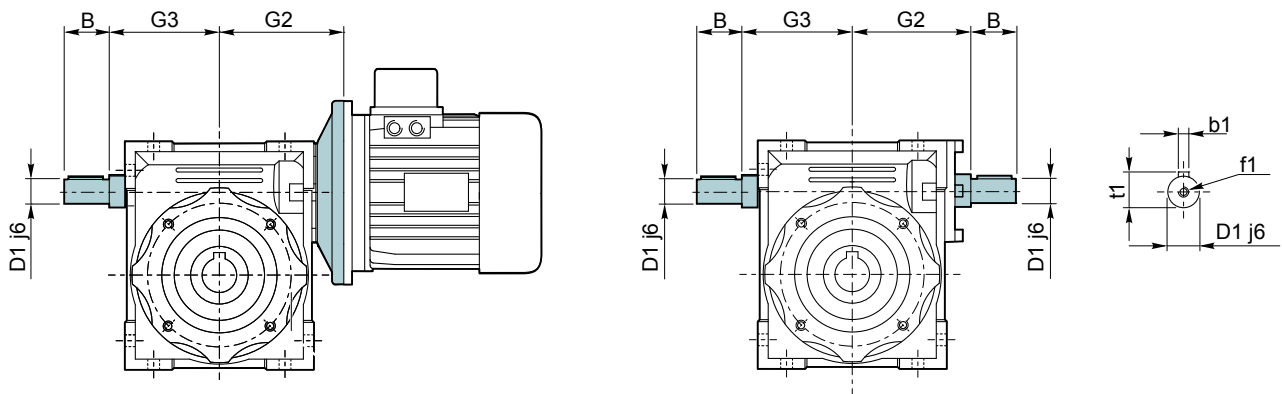
Seconda entrata / Additional input
VP / VI

VP / VI	025	030	040	050	063	075	090	110	130	150
B	20	20	23	30	40	50	50	60	80	80
D1 j6	9	9	11	14	19	24	24	28	30	35
G2	38	51	60	74	90	105	125	142	162	195
G3	37	45	53	64	75	90	108	135	155	175
b1	3	3	4	5	6	8	8	8	8	10
M12f1	-	-	-	M6	M6	M8	M8	M10	M10	M12
t1	10.2	10.2	12.5	16	21.5	27	27	31	33	38

Kit assemblaggio - Accessori / Assembly Kit - Accessories

AS Albero lento semplice / Single output shaft

AD Albero lento doppio / Double output shaft

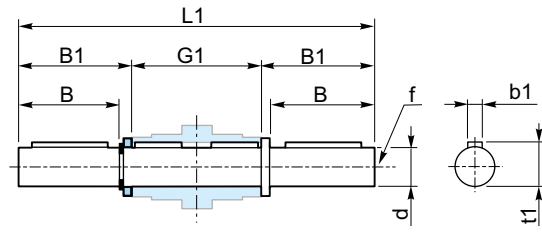
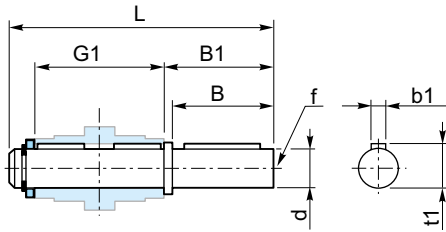

		Grandezza - Size									
Riduttore Gearbox	VP / VI	025	030	040	050	063	075	090	110	130	150
	VR	-	-	063/040	063/050 071/050	071/063	071/075 080/075	080/090 090/090	080/110 090/110	090/130	-
	VC / VS	-	025/030	025/040 030/040	030/050	030/063	040/075	040/090	050/110	063/130	063/150
d	11 g6	14 h6	18 h6	25 h6	25 h6	28 h6	35 h6	42 h6	45 h6	50 h6	
B	23	30	40	50	50	60	80	80	80	82	
B1	25.5	32.5	43	53.5	53.5	63.5	84.5	84.5	85	87	
G1	50	63	78	92	112	120	140	155	170	200	
L	81	102	128	153	173	192	234	249	265	297	
L1	101	128	164	199	219	247	309	324	340	374	
f	-	M6	M6	M10	M10	M10	M12	M16	M16	M16	
b1	4	5	6	8	8	8	10	12	14	14	
t1	12.5	16	20.5	28	28	31	38	45	48.5	53.5	
CODICE / CODE AS	AS025	AS030	AS040	AS050	AS063	AS075	AS090	AS110	AS130	AS150	
CODICE / CODE AD	AD025	AD030	AD040	AD050	AD063	AD075	AD090	AD110	AD130	AD150	

BR Braccio di reazione / Torque arm

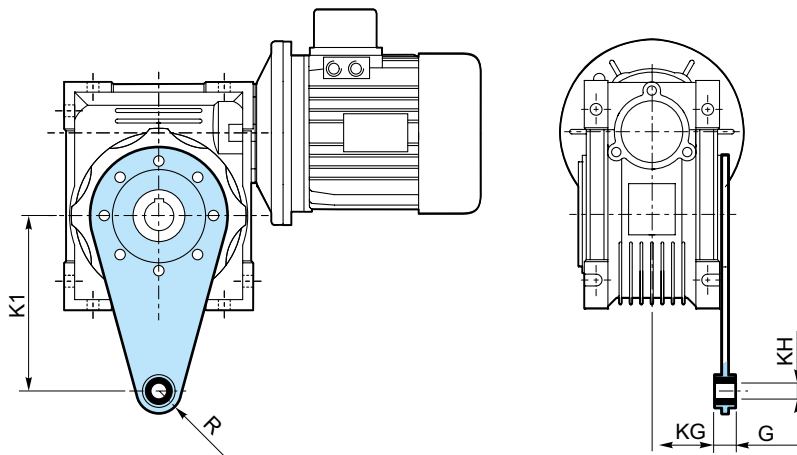

		Grandezza - Size									
Riduttore Gearbox	VP / VI	025	030	040	050	063	075	090	110	130	150
	VR	-	-	063/040	063/050 071/050	071/063	071/075 080/075	080/090 090/090	080/110 090/110	090/130	-
	VC / VS	-	025/030	025/040 030/040	030/050	030/063	040/075	040/090	050/110	063/130	063/150
K1	70	85	100	100	150	200	200	250	250	250	
G	14	14	14	14	14	25	25	30	30	30	
KG	17.5	24	31.5	38.5	49	47.5	57.5	62	69	84	
KH	8	8	10	10	10	20	20	25	25	25	
R	15	15	18	18	18	30	30	35	35	35	
CODICE / CODE	BR025	BR030	BR040	BR050	BR063	BR075	BR090	BR110	BR130	BR150	

Kit assemblaggio - Accessori / Assembly Kit - Accessories

KIT FLANGIA USCITA / KIT OUTPUT FLANGE

VP / VI

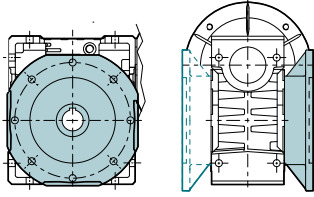

VR

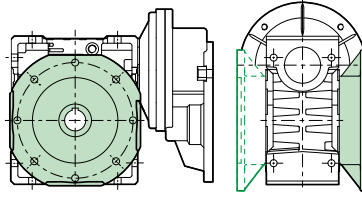

VC / VS

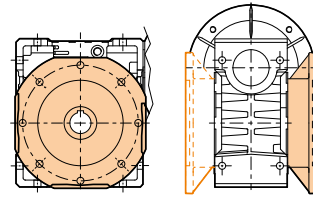

		Grandezza - Size																	
Riduttore Gearbox	VP / VI	025	030	040					050					063					
	VR	-	-	063/040					063/050 071/050					071/063					
	VC / VS	-	025/030	025/040 030/040					030/050					030/063					
TIPO FLANGIA / TYPE FLANGE		FA	FA	FA	FB	FC	FD	FE	FA	FB	FC	FD	FE	FA	FB	FC	FD	FE	
CODICE / CODE		FA025	FA030	FA040	FB040	FC040	FD040	FE040	FA050	FB050	FC050	FD050	FE050	FA063	FB063	FC063	FD063	FE063	

		Grandezza - Size														
Riduttore Gearbox	VP / VI	075			090					110			130			150
	VR	071/075 080/075			080/090 090/090					080/110 090/110			090/130			-
	VC / VS	040/075			040/090					050/110			063/130			063/150
TIPO FLANGIA / TYPE FLANGE		FA			FA	FB	FC	FD	FA			FA			FA	
CODICE / CODE		FA075			FA090	FB090	FC090	FD090	FA110			FA130			FA150	

KIT PRECOPPIA / KIT PRE-STAGE

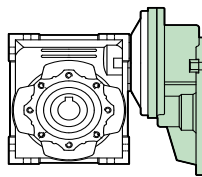

VR	CODICE / CODE
063/040	PR063 1.5 kg
063/050	
071/050	
071/063	PR071 2.6 kg
071/075	
080/075	PR080 4.7 kg
080/090	
080/110	
090/090	PR090 4.7 kg
090/110	
090/130	

Kit assemblaggio - Accessori / Assembly Kit - Accessories

KIT FLANGIA ENTRATA / KIT INPUT FLANGE

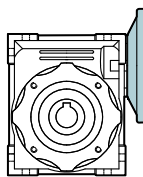

VP / NMRV	IEC	CODICE / CODE
025	56B14	FI025056B14
030	63B5	FI030063B5
	63B14	FI030063B14
	56B5	FI030056B5
	56B14	FI030056B14
	71B5	FI040071B5
040	71B14	FI040071B14
	63B5	FI040063B5
	63B14	FI040063B14
	56B5	FI040056B5
	80B5	FI050080B5
050	80B14	FI050080B14
	71B5	FI050071B5
	71B14	FI050071B14
	63B5	FI050063B5
	90B5	FI063080B5
063	90B14	FI063090B14
	80B5	FI063080B5
	80B14	FI063080B14
	71B5	FI063071B5
	71B14	FI063071B14
	100/112B5	FI075100B5
075	100/112B14	FI075100B14
	90B5	FI075080B5
	90B14	FI075090B14
	80B5	FI075080B5
	80B14	FI075080B14
	71B5	FI075071B5
	100/112B5	FI075100B5
090	100/112B14	FI075100B14
	90B5	FI075080B5
	90B14	FI075090B14
	80B5	FI075080B5
	80B14	FI075080B14
	132B5	FI110132B5
110	132 B14	FI110132B14
	100/112B5	FI110100B5
	100/112B14	FI110100B14
	90B5	FI110080B5
	90B14	FI110090B14
	80B5	FI110080B5
	132B5	FI110132B5
130	132 B14	FI110132B14
	100/112B5	FI110100B5
	100/112B14	FI110100B14
	90B5	FI110080B5
	160B5	FI150160B5
150	132B5	FI150132B5
	100/112B5	FI150100B5

Kit assemblaggio - Accessori / Assembly Kit - Accessories
KIT COMBINAZIONE VITE SENZA FINE / KIT COMBINATION WORMGEARBOXES

Albero di combinazione / Combination shaft Flangia di combinazione / Combination flange

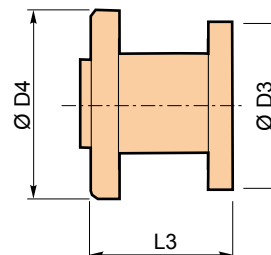
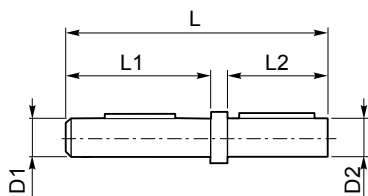
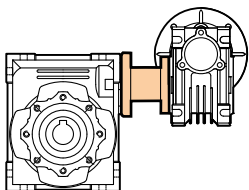

VR	CODICE / CODE	Albero di combinazione / Combination shaft					Flangia di combinazione / Combination flange		
		D1	D2	L1	L2	L	D3	D4	L3
025/030	KC025030	11	9	32	16	71.5	70	58	36.5
025/040	KC025040	11	11	32	18	75.5	70	75	41.5
030/040	KC030040	14	11	35	18	77	75	75	40
030/050	KC030050	14	14	37.5	24	82.5	75	89	40
030/063	KC030063	14	14	37.5	24	86.5	75	89	42
040/075	KC040075	18	19	40	33.5	96	87	96	41
040/090	KC040090	18	24	40	43.5	106	87	96	41
050/110	KC050110	25	28	53.5	50	134	100	115	56.5
063/130	KC063130	25	28	57.5	48	127	110	115	47
063/150	KC063150	25	38	105	70	193	110	155	52

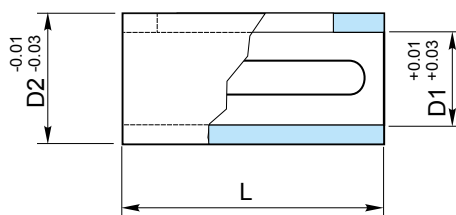
BC Boccola di riduzione in acciaio / Metal shaft sleeves

D2	11	14	19	19	24	24	28	28	38	38	42
D1	9	11	11	14	14	19	19	24	24	28	38
CODICE / CODE	BC1109	BC1411	BC1911	BC1914	BC2414	BC2419	BC2819	BC2824	BC3824	BC3828	BC4238

Disegno esploso / Exploded view

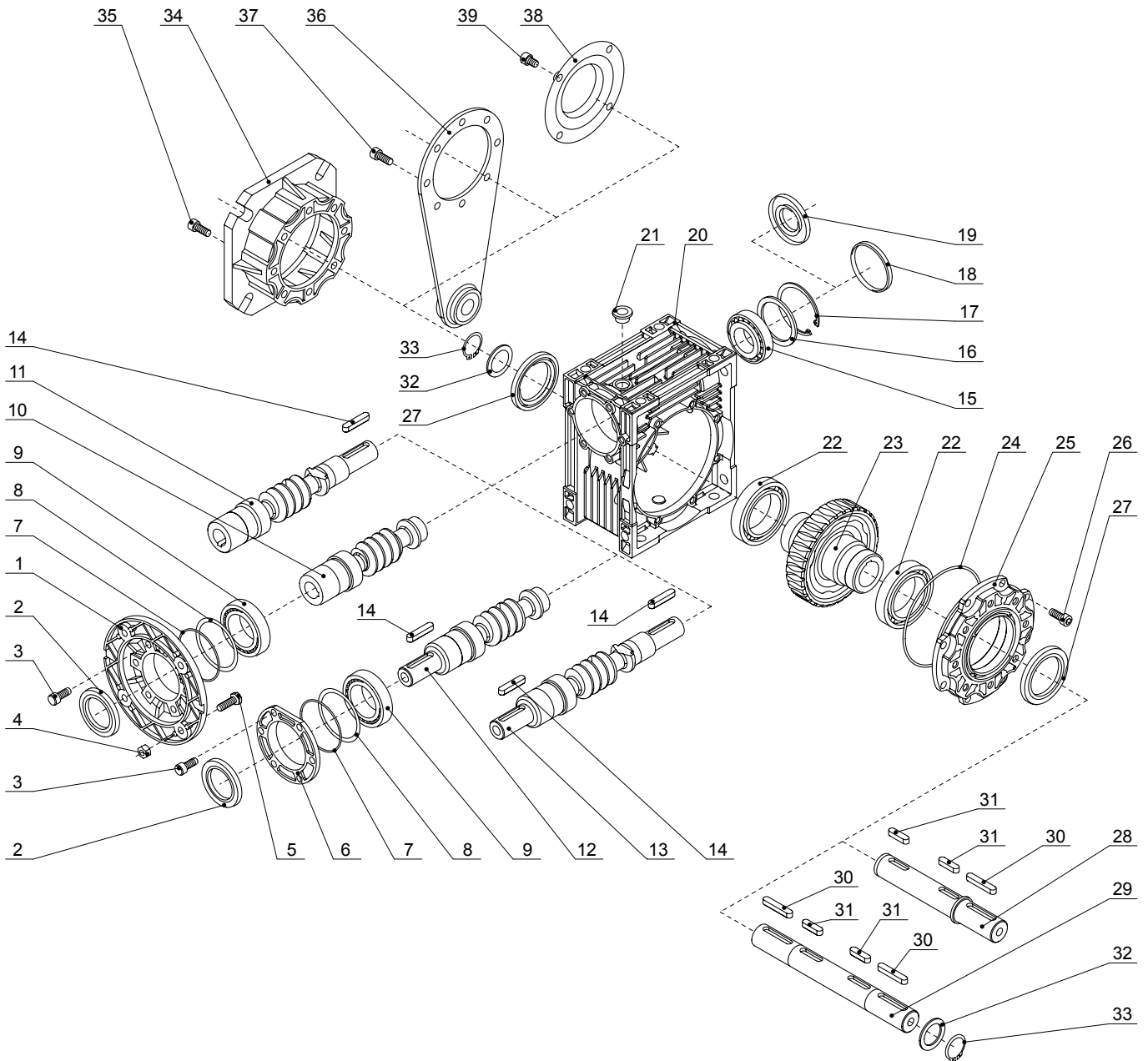

1	Flangia Motore Flange PAM	11	Vite PAM seconda entrata Double ext. PAM worm	21	Tappo Plug cock	31	Linguetta Parallel key
2	Paraolio Oil seal	12	Vite sporgente RV worm	22	Cuscinetto Bearing	32	Rondella Washer
3	Vite Hexagon socket head cap screw	13	Vite sporgente seconda entrata Double ext. RV worm	23	Corona Worm wheel	33	Seeger Circlips
4	Grano Hexagon nuts	14	Linguetta entrata Parallel key	24	O-ring O-ring	34	Flangia uscita Output flange
5	Vite Hexagon bolt	15	Cuscinetto Bearing	25	Coperchio pendolare Bearing support cover	35	Vite Hexagon socket head cap screw
6	Coperchio Gear unit cover	16	Distanziale Washer	26	Vite Hexagon socket head cap screw	36	Braccio reazione Torque arm
7	O-ring O-ring	17	Seeger Circlips	27	Paraolio Oil seal	37	Vite Hexagon socket head cap screw
8	Rasamento Spacer shim	18	Cappello Cap	28	Albero lento semplice Single output Shaft	38	Coperchio protezione Protection cap
9	Cuscinetto Bearing	19	Paraolio Oil seal	29	Albero lento doppio Double output Shaft	39	Vite Hexagon socket head cap screw
10	Vite PAM PAM worm	20	Carcassa Housing	30	Linguetta Parallel key		

Disegno esploso / Exploded view

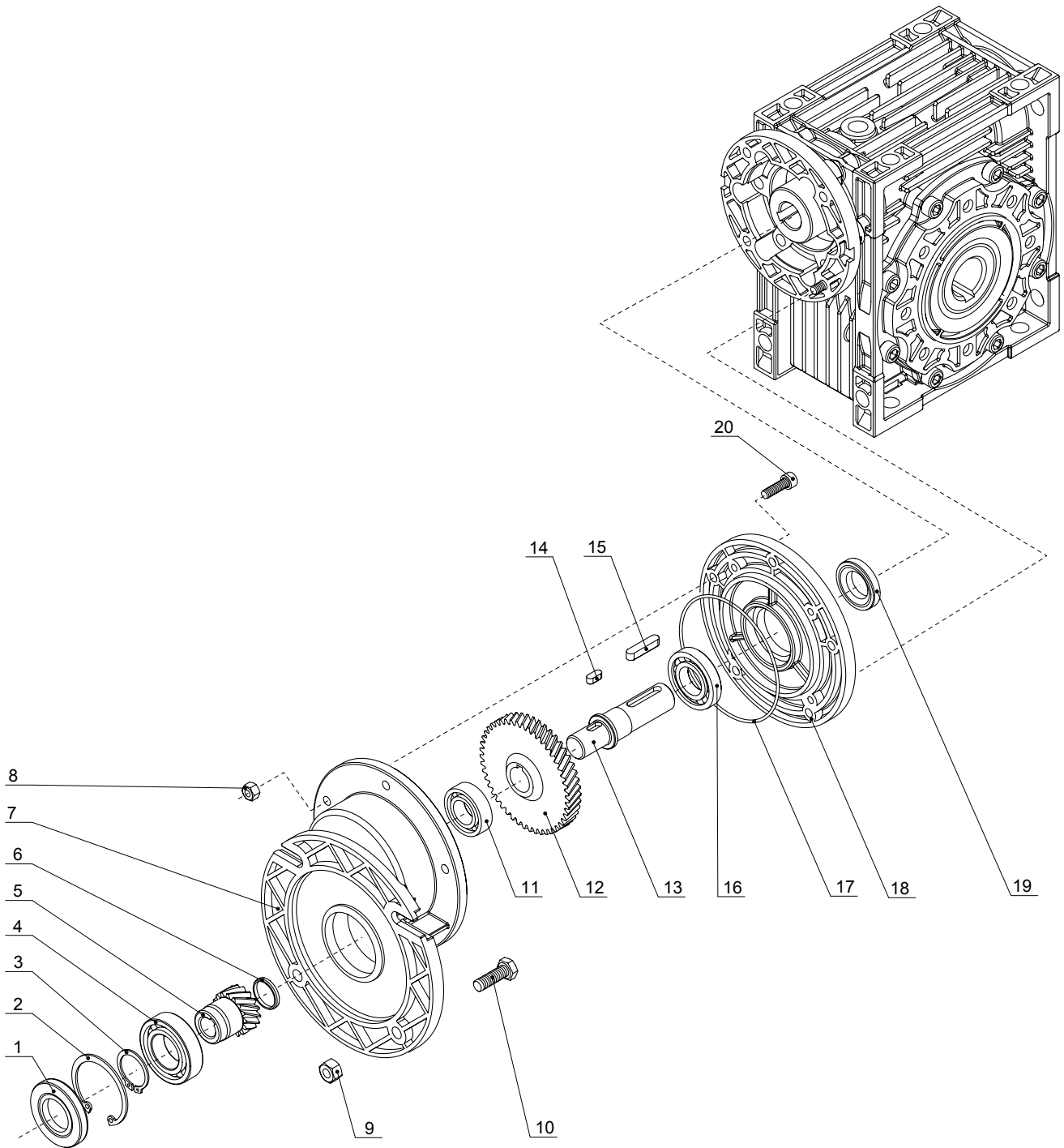

1	Paraolio Oil seal	6	Cappello Cap	11	Cuscinetto Bearing	16	Cuscinetto Bearing
2	Seeger Circlips	7	Cassa precoppia Pre-stage housing	12	Ingranaggio Gear	17	O-ring O-ring
3	Seeger Circlips	8	Grano Hexagon nuts	13	Albero Low speed shaft	18	Coperchio uscita Output cover
4	Cuscinetto Bearing	9	Grano Hexagon nuts	14	Linguetta Parallel key	19	Paraolio Oil seal
5	Pinion Hollow pinion	10	Vite Hexagon bolt	15	Linguetta Parallel key	20	Vite Hexagon socket head cap screw

I **motori elettrici** proposti dalla SATI sono costruiti secondo le dimensioni delle norme internazionali: flange, alberi e fissaggio a piedi sono dimensionati secondo le dimensioni richiamate dalla normativa IEC 72-1 e IEC 34-7.

La costruzione dei motori è chiusa, ventilata esternamente e con rotore a gabbia equilibrato dinamicamente.

Tutti i motori della gamma SATI sono avvolti per collegamento stella/triangolo, nei quali il voltaggio alto corrisponde all'avvolgimento a stella ed il voltaggio basso al collegamento a triangolo.

I motori **fino alla taglia 100** compresa sono a **230/400 V 50 Hz** e solo i motori delle grandezze 112, 132 e 160 sono avvolti a 400/690 V 50 Hz.

La tensione nominale dei motori SATI (V. 230/400 - 50 Hz) ammette una variazione $\pm 10\%$.

*SATI's **electric motors** are manufactured according to the dimensions stated in the relevant international standards: flanges, shafts and feet attachments to the base are dimensioned according to IEC 72-1 and IEC 34-7 regulations.*

The motor housing is enclosed, with outer fan and with a shielded and dynamically balanced rotor.

All SATI electric motors are wound in star/delta connection: the high voltage corresponds to the star connection and the low voltage corresponds to the delta connection.

*Motors **up to size 100** are wound at **230/400 V 50 Hz** and only motors of sizes 112, 132 and 160 are wound at 400/690 V 50 Hz.*

The rated voltage of motors (230/400 V - 50 Hz) can function with a variation of $\pm 10\%$.



Motori asincroni trifase / Asynchronous three-phase motors
2 Poli / poles
MOTORE / MOTOR

	Motore Motor	Classe energetica Energy class	Grandezza Size	Potenza kW Power kW	Numero di poli Number of poles	Forma costruttiva Version
ES. DESIGNAZIONE EX. DESIGNATION	M	1	063	0.25	2P	B5
ES. CODICE EX. CODE	M	1	063	025	2	B5

Caratteristiche tecniche 2 Poli - 2800 rpm / Technical characteristics 2 Poles - 2800 rpm

Codice code			Tipo Type	Potenza Power	Tensione Voltage	Corrente Current	Classe energetica Energy class	Rendimento Efficiency	Fattore di potenza Power factor	Coppia nominale Rated torque	Coppia spunto / Cn Starting torque / Cn	Peso Weight		
B5	B3	B14		kW	V	A (400V)		%	cos Φ	Cn (Nm)	Cs/Cn	B3 (kg)	B5 (kg)	B14 (kg)
M10560092B5	M10560092B3	M10560092B14	56A	0.09	230/400	0.36	IE1	53	0.72	0.502	2.2	2.6	2.8	2.8
M10560122B5	M10560122B3	M10560122B14	56B	0.12	230/400	0.40	IE1	61	0.72	0.534	2.2	3	3.2	3.2
M10630182B5	M10630182B3	M10630182B14	63A	0.18	230/400	0.55	IE1	63	0.75	0.641	2.2	4	4.2	4.2
M10630252B5	M10630252B3	M10630252B14	63B	0.25	230/400	0.71	IE1	65	0.78	0.884	2.2	4.2	4.5	4.5
M10630372B5	M10630372B3	M10630372B14	63C	0.37	230/400	1.05	IE1	65	0.78	1.264	2.2	4.7	5.2	5.2
M10710372B5	M10710372B3	M10710372B14	71A	0.37	230/400	0.97	IE1	70	0.79	1.262	2.2	5.2	5.5	5.5
M10710552B5	M10710552B3	M10710552B14	71B	0.55	230/400	1.42	IE1	71	0.79	1.869	2.2	6	6.8	6.8
M20800752B5	M20800752B3	M20800752B14	80A	0.75	230/400	1.86	IE2	77.4	0.75	2.51	2.7	9.3	9.4	9.3
M20801102B5	M20801102B3	M20801102B14	80B	1.1	230/400	2.52	IE2	79.6	0.79	3.69	2.7	10.5	10.6	10.5
M20901502B5	M20901502B3	M20901502B14	90S	1.5	230/400	3.17	IE2	81.3	0.84	5.02	2.3	13.5	12.8	12.7
M20902202B5	M20902202B3	M20902202B14	90L	2.2	230/400	4.54	IE2	83.2	0.84	7.38	2.6	16.2	16.2	15.9
M21003002B5	M21003002B3	M21003002B14	100L	3	230/400	5.75	IE2	84.6	0.89	10.05	2.5	23.2	23.3	23.2
M21124002B5	M21124002B3	M21124002B14	112M	4	400/690	7.56	IE2	85.8	0.89	13.13	2.5	27.2	27.3	27.2
M21325502B5	M21325502B3	M21325502B14	132SA	5.5	400/690	10.25	IE2	87	0.89	18.08	2.4	42.6	45.3	42.6
M31327502B5	M31327502B3	M31327502B14	132SB	7.5	400/690	13.65	IE3	90.1	0.88	24.61	2.7	45.4	45.6	45.4

Nota:

I dati tecnici indicati in tabella si riferiscono ad una tensione di alimentazione di 400 V, 50 Hz.

Note:

Technical characteristics are referred to voltage 400 V, 50 Hz.

Motori asincroni trifase / Asynchronous three-phase motors

4 Poli / poles

MOTORE / MOTOR						
	Motore Motor	Classe energetica Energy class	Grandezza Size	Potenza kW Power kW	Numero di poli Number of poles	Forma costruttiva Version
ES. DESIGNAZIONE EX. DESIGNATION	M	1	063	0.25	4P	B5
ES. CODICE EX. CODE	M	1	063	025	4	B5

Caratteristiche tecniche 4 Poli - 1400 rpm / Technical characteristics 4 Poles - 1400 rpm														
Codice code			Tipo Type	Potenza Power	Tensione Voltage	Corrente Current	Classe energetica Energy class	Rendimento Efficiency	Fattore di potenza Power factor	Coppia nominale Rated torque	Coppia spunto / Cn Starting torque / Cn	Peso Weight		
B5	B3	B14		kW	V	A (400V)		%	cos Φ	Cn (Nm)	Cs/Cn	B3 (kg)	B5 (kg)	B14 (kg)
M10560064B5	M10560064B3	M10560064B14	56A	0.06	230/400	0.35	IE1	50	0.56	0.478	2.3	2.9	3.2	3.2
M10560094B5	M10560094B3	M10560094B14	56B	0.09	230/400	0.45	IE1	52	0.59	0.65	2.3	3.2	3.5	3.5
M10630124B5	M10630124B3	M10630124B14	63A	0.12	230/400	0.55	IE1	52	0.64	0.93	2.2	3.7	4	4
M10630184B5	M10630184B3	M10630184B14	63B	0.18	230/400	0.70	IE1	57	0.65	1.28	2.2	4.2	4.6	4.6
M10630254B5	M10630254B3	M10630254B14	63C	0.25	230/400	0.91	IE1	60	0.66	1.77	2.2	5	5.5	5.5
M10710254B5	M10710254B3	M10710254B14	71A	0.25	230/400	0.84	IE1	60	0.72	1.78	2.2	5	5.8	5.8
M10710374B5	M10710374B3	M10710374B14	71B	0.37	230/400	1.11	IE1	65	0.74	2.62	2.2	5.8	6.3	6.3
M10710554B5	M10710554B3	M10710554B14	71C	0.55	230/400	1.6	IE1	66	0.75	3.86	2.2	6.5	7	7
M10800554B5	M10800554B3	M10800554B14	80A	0.55	230/400	1.58	IE1	67	0.75	3.87	2.2	8.1	8.6	8.6
M20800754B5	M20800754B3	M20800754B14	80B	0.75	230/400	1.79	IE2	79.6	0.76	5.04	2.3	10.2	10.5	10.2
M20801104B5	M20801104B3	M20801104B14	90S	1.1	230/400	2.5	IE2	81.4	0.78	7.37	2.3	12.7	12.9	12.7
M20901504B5	M20901504B3	M20901504B14	90L	1.5	230/400	3.31	IE2	82.8	0.79	10.09	2.4	15.5	15.6	15.5
M21002204B5	M21002204B3	M21002204B14	100LA	2.2	230/400	4.83	IE2	84.3	0.82	14.69	2.4	24.9	24.9	24.9
M21003004B5	M21003004B3	M21003004B14	100LB	3	230/400	6.33	IE2	85.5	0.80	20.03	2.4	25.3	25.9	25.3
M21124004B5	M21124004B3	M21124004B14	112M	4	400/690	8.23	IE2	86.6	0.79	26.62	2.5	30.3	32.3	30.3
M21325504B5	M21325504B3	M21325504B14	132S	5.5	400/690	10.9	IE2	87.7	0.82	36.73	2.3	44.9	45.3	44.9
M31327504B5	M31327504B3	M31327504B14	132M	7.5	400/690	14.43	IE3	90.4	0.83	50.08	2.3	56.9	57.4	56.9
M316011X4B5	M316011X4B3	M316011X4B14	160M	11	400/690	19.09	IE3	91.4	0.91	72.95	2.5	80.9	82.2	80.9
M316015X4B5	M316015X4B3	M316015X4B14	160L	15	400/690	25.55	IE3	92.1	0.92	99.13	2.4	96	97.7	96

Nota:
I dati tecnici indicati in tabella si riferiscono ad una tensione di alimentazione di 400 V, 50 Hz.

Note:
Technical characteristics are referred to voltage 400 V, 50 Hz.

Motori asincroni trifase / Asynchronous three-phase motors
6 Poli / poles
MOTORE / MOTOR

	Motore Motor	Classe energetica Energy class	Grandezza Size	Potenza kW Power kW	Numero di poli Number of poles	Forma costruttiva Version
DESIGNAZIONE DESIGNATION	M	2	080	0.37	6P	B5
CODICE CODE	M	2	080	037	6	B5

Caratteristiche tecniche 6 Poli - 900 rpm / Technical characteristics 6 Poles - 900 rpm

Codice code			Tipo Type	Potenza Power	Tensione Voltage	Corrente Current	Classe energetica Energy class	Rendimento Efficiency	Fattore di potenza Power factor	Coppia nominale Rated torque	Coppia spunto / Cn Starting torque / Cn	Peso Weight		
B5	B3	B14		kW	V	A (400V)		%	cos Φ	Cn (Nm)	Cs/Cn	B3 (kg)	B5 (kg)	B14 (kg)
M10630126B5	M10630126B3	M10630126B14	63B	0.12	230/400	0.62	IE1	45	0.62	1.18	2	4.5	4.8	4.8
M10710186B5	M10710186B3	M10710186B14	71A	0.18	230/400	0.70	IE1	56	0.66	1.93	1.7	5.6	6.1	6.1
M10710256B5	M10710256B3	M10710256B14	71B	0.25	230/400	0.87	IE1	59	0.7	2.36	2.1	6	6.8	6.8
M10710376B5	M10710376B3	M10710376B14	71C	0.37	230/400	1.27	IE1	61	0.69	3.93	2	6.8	7.6	7.6
M10800376B5	M10800376B3	M10800376B14	80A	0.37	230/400	1.23	IE1	62	0.7	3.9	1.9	8.1	8.9	8.9
M10800556B5	M10800556B3	M10800556B14	80B	0.55	230/400	1.65	IE1	67	0.72	5.84	2	9.6	10.6	10.6
M20900756B5	M20900756B3	M20900756B14	90S	0.75	230/400	1.88	IE2	75.9	0.76	7.66	2.2	12.9	13.2	12.9
M20901106B5	M20901106B3	M20901106B14	90L	1.1	230/400	2.54	IE2	78.1	0.80	11.23	2.3	14.9	15.7	14.9
M21001506B5	M21001506B3	M21001506B14	100L	1.5	230/400	3.31	IE2	79.8	0.82	15.24	2.3	20.7	20.8	20.7
M21122206B5	M21122206B3	M21122206B14	112M	2.2	400/690	4.85	IE2	81.8	0.80	22.35	2.3	33.3	34.5	33.3
M21323006B5	M21323006B3	M21323006B14	132S	3	400/690	6.26	IE2	83.3	0.83	30.48	2.4	38.3	39.5	38.3
M21324006B5	M21324006B3	M21324006B14	132MA	4	400/690	8.12	IE2	84.6	0.84	40.42	2.5	43.3	44.4	43.3
M21325506B5	M21325506B3	M21325506B14	132MB	5.5	400/690	11.26	IE2	86	0.82	55.58	2.3	58.2	59.1	58.2

Nota:

I dati tecnici indicati in tabella si riferiscono ad una tensione di alimentazione di 400 V, 50 Hz.

Note:

Technical characteristics are referred to voltage 400 V, 50 Hz.

Dimensioni d'ingombro / Dimensions

Tipo/ Type	B3 / B5 / B14				
	D	E	F	O	SS
56	Ø9	20	3	10.2	M3
63	Ø11	23	4	12.5	M4
71	Ø14	30	5	16	M5
80	Ø19	40	6	21.5	M6
90S	Ø24	50	8	27	M8
90L	Ø24	50	8	27	M8
100	Ø28	60	8	31	M10
112	Ø28	60	8	31	M10
132S	Ø38	80	10	41	M12
132M/L	Ø38	80	10	41	M12
160M/L	Ø42	110	12	45	M16

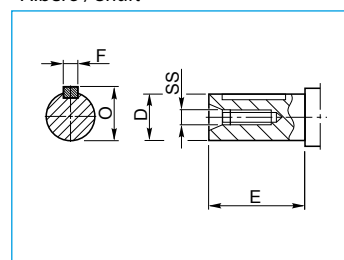
Albero / Shaft

Dimensioni d'ingombro motori IE1 / Dimensions motors IE1

Tipo/ Type	B3							B5					B14					B3 / B5 / B14		
	H	A	AA	AD	B	C	K	M	N	P	T	S	N	M	P	T	S	HD	AC	L
56	56	90	110	156	71	36	5.8X8.8	Ø100	Ø80	Ø120	3	Ø7	Ø50	Ø65	Ø80	2.5	M5	100	Ø117	196
63	63	100	120	171	80	40	7X10	Ø115	Ø95	Ø140	3	Ø10	Ø60	Ø75	Ø90	2.5	M5	108	Ø130	220
71	71	112	132	186	90	45	7X10	Ø130	Ø110	Ø160	3.5	Ø10	Ø70	Ø85	Ø105	2.5	M6	115	Ø147	241
80	80	125	160	213	100	50	10X13	Ø165	Ø130	Ø200	3.5	Ø12	Ø80	Ø100	Ø120	3	M6	133	Ø163	290
90S	90	140	175	229	100	56	10X13	Ø165	Ø130	Ø200	3.5	Ø12	Ø95	Ø115	Ø140	3	M8	139	Ø183	312
90L	90	140	175	229	125	56	10X13	Ø165	Ø130	Ø200	3.5	Ø12	Ø95	Ø115	Ø140	3	M8	139	Ø183	337/367
100	100	160	198	252	140	63	12X15	Ø215	Ø180	Ø250	4	Ø15	Ø110	Ø130	Ø160	3.5	M8	152	Ø205	369
112	112	190	220	279	140	70	12X15	Ø215	Ø180	Ø250	4	Ø15	Ø110	Ø130	Ø160	3.5	M8	167	Ø229	395
132S	132	216	252	318	140	89	12X15	Ø265	Ø230	Ø300	4	Ø15	Ø130	Ø165	Ø200	4	M10	186	Ø265	437
132M/L	132	216	252	318	178	89	12X15	Ø265	Ø230	Ø300	4	Ø15	Ø130	Ø165	Ø200	4	M10	186	Ø265	475/501
160M/L	160	254	290	384	210/254	108	15X19	Ø300	Ø250	Ø350	5	Ø19	Ø180	Ø215	Ø250	4	M12	224	Ø325	640

Nota:
Dimensioni dei motori IE1 e IE2 contattare servizio tecnico SATI

Note:
Dimensions of motors IE1 e IE2, contact the technical department SATI.

B3

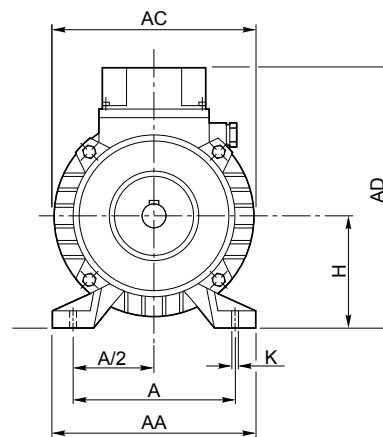
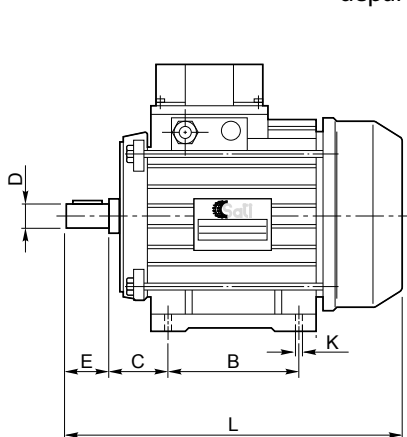

B5

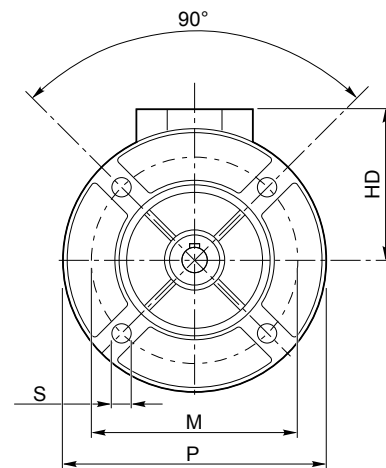
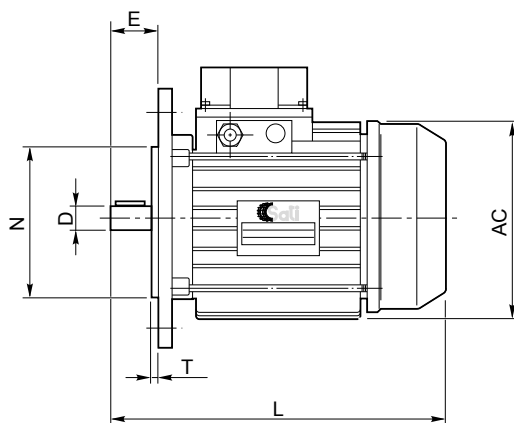

B14

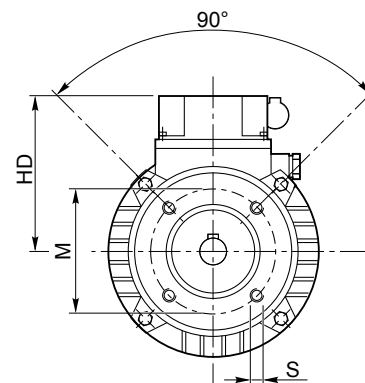
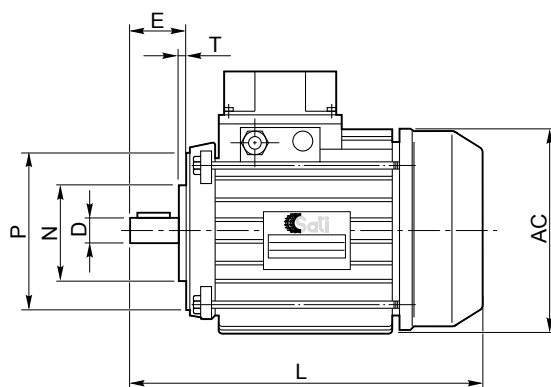

Caratteristiche tecniche / Technical specifications

L'uso dei motori con frequenza di alimentazione di 60Hz non è consentito, a meno che non si tratti del range di voltaggio indicato nella successiva tabella.

The rated voltage (230/400 V - 50 Hz or 400/690 - 50 Hz) can tolerate a variation of $\pm 10\%$.

Tipo	220/380 - 50Hz	240/415 - 50Hz	260/440 - 60Hz	280/480 - 60Hz	400/690 - 50Hz
56	●	●	●	●	
63	●	●	●	●	
71	●	●	●	●	
80	●	●	●	●	
90	●	●	●	●	
100	●	●	●	●	
112					●
132					●
160					●

Le caratteristiche di protezione e funzionamento sono le seguenti:

Protezione: IP 55
 Isolamento: classe F
 Servizio: S 1

Le macchine sono costruite con materiali di sicura qualità; in particolare, la carcassa è in alluminio pressofuso, gli alberi in acciaio C 40, la copriventola in lamiera stampata e fissata con viti al corpo carcassa, rotore in alluminio e statore isolato con materiali idonei alla classificazione "F".

The specifications regarding protection and operation are as follows:

*Protection: IP 55
 Insulation: class F
 Service: S 1*

The motors are built from high-quality materials; in particular, the casing is in pressure-cast aluminium, the shafts in C 40 steel, the fan cover is in stamped sheet metal and fixed with screws to the casing, the rotor is made from aluminium and the stator is insulated with materials conforming to "F" classification.

Protezione / Protection

I tipi di protezione indicati dalla norma (CEI EN 60529 - IEC 34/5) sono identificati dalla sigla "IP" seguita da due cifre che determinano le caratteristiche della protezione stessa: la prima sta ad indicare la protezione contro la penetrazione di materie estranee o contatti accidentali e la seconda contro l'acqua.

Prima cifra:

- 0 Nessuna protezione
- 1 Contro penetrazione di corpi di grandi dimensioni
- 2 Contro penetrazione di corpi di medie dimensioni
- 3 Contro penetrazione di corpi di piccole dimensioni
- 4 Contro penetrazione di corpi di minuscole dimensioni
- 5 Contro depositi interni di polvere
- 6 Protezione totale da depositi interni di polvere

Seconda cifra:

- 0 Nessuna protezione
- 1 Contro penetrazione verticale di gocce d'acqua
- 2 Contro penetrazione inclinata di gocce d'acqua
- 3 Contro spruzzi fini d'acqua
- 4 Contro spruzzi d'acqua
- 5 Contro getti d'acqua
- 6 Contro l'inondazione
- 7 Contro l'immersione
- 8 Contro la sommersione

The types of protection conforming to regulations (EN 60529 - IEC 34/5) are identified by the mark "IP" followed by two numbers which lay down the specifications of the actual protection: the first represents the degree of protection against penetration of extraneous material or accidental contacts and the second against penetration of water.

First number:

- 0 No protection
- 1 Against penetration by large objects
- 2 Against penetration by medium-sized objects
- 3 Against penetration by small objects
- 4 Against penetration by tiny objects
- 5 Against internal deposits of dust
- 6 Total protection form internal deposits of dust

Second number:

- 0 No protection
- 1 Against vertical penetration of drops of water
- 2 Against inclined penetration of drops of water
- 3 Against fine water spray
- 4 Against water spray
- 5 Against jets of water
- 6 Against floods
- 7 Against immersion
- 8 Against submersion

Servizio / Operative use

Quando il carico è costante o varia con criteri conosciuti, si può rappresentare con valori numerici o con grafici indicanti la variazione del carico al passare del tempo. In caso contrario, la tabella di seguito riportata detta alcuni parametri dei servizi di lavoro.

S1 Funzionamento a carico costante e di durata sufficiente al raggiungimento dell'equilibrio termico (**servizio continuo**).

S2 Funzionamento a carico costante per un periodo di tempo inferiore a quanto sopra, seguito da un periodo di riposo sufficiente a ristabilire tra temperatura della macchina e quello del fluido, l'uguaglianza con una tolleranza di 2° (**servizio di durata limitata**)

S3 Sequenza di cicli identici di funzionamento, ciascuno comprendente fasi di riposo e di lavoro a carico costante (**servizio intermittente periodico**)

S4 Sequenza di cicli identici di funzionamento, ciascuno comprendente fasi trascurabili di avviamento. Un periodo di lavoro a carico costante ed un periodo di riposo; in questo caso è consigliabile indicare il n° di inserzioni/h (**Servizio periodico con avviamento**)

S5 Come S4, ma con frenata rapida (**servizio periodico con frenata**)

S6 Sequenza di cicli identici di funzionamento, ciascuno comprendente un periodo di carico costante ed un periodo di funzionamento a vuoto senza alcun periodo di riposo (**servizio ininterrotto periodico con carico intermittente**)

S7 Sequenza di cicli di funzionamento come S5, ma senza periodi di riposo (**servizio ininterrotto periodico con frenata**)

S8 Sequenza di cicli identici di funzionamento, ciascuno comprendente un periodo di carico costante ad una velocità prestabilita, seguito da cicli a carico costante ma a velocità diverse, senza periodo di riposo (**servizio ininterrotto periodico con variazioni correlate di carico e velocità**)

S9 Carico e velocità variano in modo non periodico compreso frequenti sovraccarichi, superiori al valore a pieno carico (**servizio con variazioni, non periodiche, di carico e velocità**).

When the load is constant or varies by known criteria, the actual loading cycle can be shown through numbers or in a graph form, showing the load variation while time is elapsing. If this is not the case, the table below provides some parameters suitable for operative use.

S1 Operation under constant load and for a sufficient duration for thermal equilibrium to be reached (**continuous operation**).

S2 Operation under constant load for less time than above, followed by a rest phase sufficient to re-establish a balance between the temperature of the machine and that of fluid within a tolerance of 2° (**operation for a limited period of time**).

S3 A series of identical work cycles, each including rest phases and constant load work phases (**periodic intermittent operation**).

S4 A series of identical work cycles, each including negligible start-up phases, a work phase under constant load and a rest; in this case, it is advisable to indicate the number of start-ups per hour (**periodic operation with start-up**).

S5 As per S4 but with rapid electrical braking (**periodic operation with braking**).

S6 A sequence of identical work cycles, each including a period of constant load and a period of idling but without any rest phases (**uninterrupted periodic operation with intermittent load**).

S7 Sequence of cycles as per S5 but without any rest phases (**uninterrupted periodic operation with braking**).

S8 A sequence of identical work cycles, each including a period of constant load at a certain pre-established velocity, followed by constant load period but at different velocities, without any rest phase (**uninterrupted periodic operation with correlated variations of load and velocity**).

S9 Load and velocity vary in a non-periodic manner and include frequent overloads which are greater than the value at full load (**operation with non-periodic variations of load and velocity**).

Caratteristiche elettriche generali / General electrical specifications

Tensione nominale: è la tensione che normalmente si ha nei morsetti di alimentazione

Potenza nominale: è la potenza sviluppata, all'albero

Coppia nominale: è il fattore risultante dalla potenza nominale ed i giri nominali

Coppia massima: è la coppia che si ottiene dal motore alimentato a tensione e frequenza nominali.

Rated voltage: this is the voltage which is normally available from power supply terminals.

Nominal power: this is the power generated at the shaft.

Rated torque: this is the factor derived from the nominal power and the nominal revolutions.

Maximum torque: this is the torque obtained from the motor operating with nominal voltage and frequency.

Temperature di funzionamento:

Operating temperatures:

classe di isolamento/ insulation category	temperatura limite di esercizio/ upper temperature operating limit
A	105°C
E	120°C
B	130°C
F	155°C
H	180°C

Attenzione

La temperatura indicata in tabella, è comprensiva della temperatura ambiente (es. se si ha una temperatura nell'area di lavoro di 30 ° C, un motore con isolamento H può funzionare con temperatura propria di 150°C).

Important note

The temperature shown in the table includes the ambient temperature (eg, if the temperature in the work area is 30°C, a motor with insulation category H can safely operate with a working temperature of its own of 150°C).

Schemi di collegamenti / Diagram of connections

(Prodotto escluso dal campo di applicazione del Sistema Qualità ISO 9001)
 (This product is excluded from the scope of ISO 9001 Quality Management System)

Motori asincroni trifase / Three-phase asynchronous motors

220 Volt

Collegamento triangolo / Triangle connection

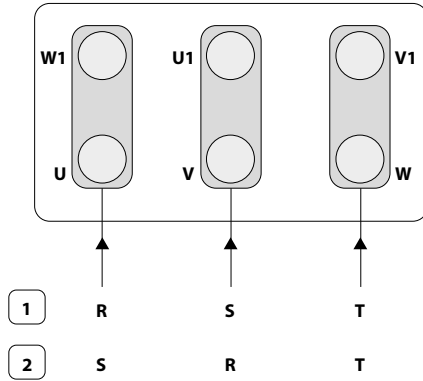

1 Rotazione oraria/Clockwise rotation

380 Volt

Collegamento stella / Star connection

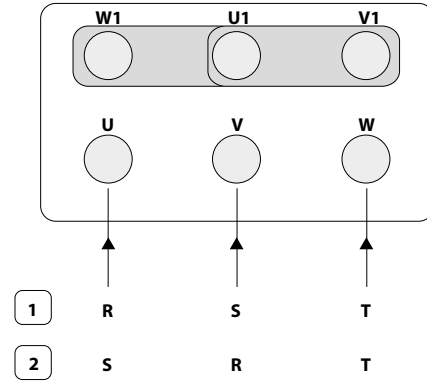

2 Rotazione antioraria/Anti-clockwise rotation

Motori monofase / Monophase motors

Rotazione antioraria / Anti-clockwise rotation

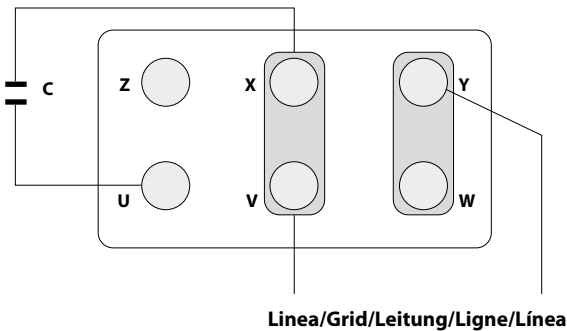

Rotazione oraria / Clockwise rotation

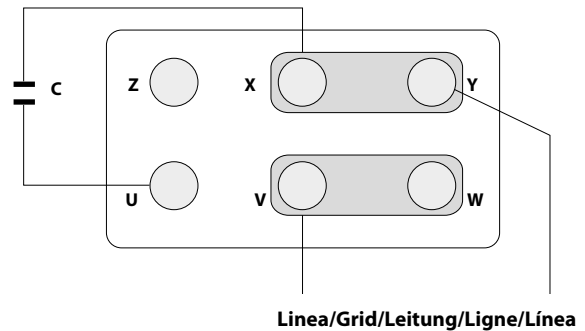

Avviamento con collegamento diretto /Starting up with direct connection

È il metodo più semplice e corrente per motori di piccola-media potenza, collegando direttamente i morsetti dell'avvolgimento alla linea.

This is the simplest and most common method for low to medium-power motors, executed by connecting the clips from the winding directly to the power source.

Avviamento stella triangolo /Starting up with star-triangle

Per motori di media-grossa potenza occorre verificare lo spunto di avviamento, in quanto, se origina valori superiori a quanto disponibili in rete occorre provvedere a collegamenti con partenza a stella-triangolo, interponendo, tra la linea ed il motore, un apposito avviatore.

In motors of medium to high power, it is necessary to ascertain the energy needed to overcome the starting resistance since, if this should be greater than that available in the electrical grid, it will be necessary to use a series of connections with a star-triangle start-up and to place a suitable starter between grid and motor.

Posizioni di piazzamento / Mounting positions

(Prodotto escluso dal campo di applicazione del Sistema Qualità ISO 9001)
 (This product is excluded from the scope of ISO 9001 Quality Management System)

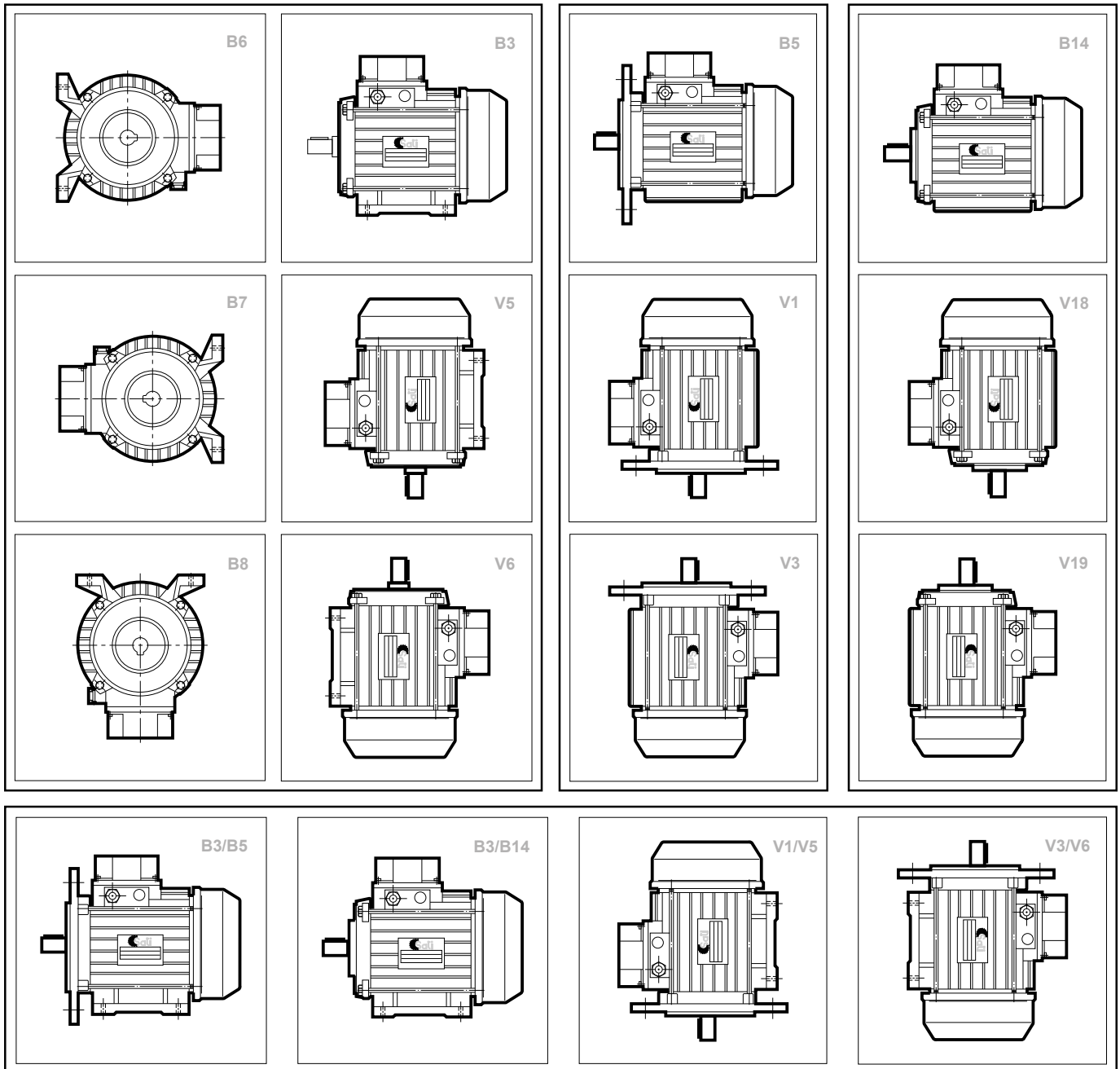

1. **ORDINI.** Per la vendita dei propri articoli SATI S.p.A. accetta unicamente ordini scritti. Invitiamo a consultare il catalogo indicando i nostri codici prodotto e ad inviare gli ordini a mezzo fax, e-mail o web. Una volta iniziata la lavorazione o l'imballo dei pezzi non vengono accettati annullamenti o riduzioni dell'ordine – salvo differenti accordi con il nostro personale interno. Per i prodotti realizzati su specifica del cliente, il numero di pezzi spediti può variare del $\pm 5\%$ rispetto alla quantità ordinata; la fatturazione al committente viene adeguata di conseguenza.
 2. **PREZZI.** I prezzi vengono concordati in fase di offerta o fanno riferimento al listino generale. SATI S.p.A. si riserva la facoltà di modificare le proprie quotazioni, ove ciò si rendesse necessario come conseguenza di mutate condizioni di mercato e di produzione.
 3. **DIVIETO DI CESSIONE.** Gli obblighi e i diritti del Cliente non possono essere ceduti a terzi senza la previa autorizzazione di SATI S.p.A.
 4. **TERMINI E MODALITÀ DI PAGAMENTO.** I termini e le modalità di pagamento devono essere preventivamente concordati con il nostro ufficio vendite. Non sono consentiti arrotondamenti o trattenute sugli importi dovuti se non autorizzati dall'ufficio vendite. L'insolvenza di R.I.B.A. e ogni ritardato pagamento genera l'addebito di spese e di interessi di mora fino al massimo previsto dalla legge. Le commissioni della banca estera relative ai pagamenti sono a carico dell'ordinante.
 5. **RISERVA DI PROPRIETÀ.** La merce viene venduta con riserva di proprietà, fino al pagamento dell'intero prezzo, compresi eventuali interessi e accessori.
Il rilascio di cambiali ed eventuali loro rinnovi, anche parziali, da parte del Cliente, non può considerarsi estinzione, né quale novazione né quale pagamento definitivo del prezzo, se non a buon fine delle cambiali stesse; analogamente, il rilascio di cambiali non può pregiudicare la riserva di proprietà.
Nonostante quanto precede, il rischio di perdita, perimento o danneggiamento viene trasferito al Cliente in sede di consegna in conformità con quanto previsto negli art. 6 e 8 delle presenti condizioni.
 6. **TERMINI DI CONSEGNA.** I termini di consegna delle forniture devono essere concordati ad ogni ordine. In caso di difficoltà nell'approvvigionamento dei materiali o comunque in tutti i casi di forza maggiore, i termini di consegna possono subire variazioni senza pregiudicare la validità dell'ordine. Nel caso di prodotti realizzati su specifica, il Cliente è in ogni caso tenuto al ritiro del materiale ordinato. E' in ogni caso esclusa la responsabilità della SATI S.p.A. per danni da mancata o ridotta produzione, nonché per danni indiretti e consequenziali, derivanti nel ritardo nella consegna dei prodotti ordinati.
 7. **IMBALLO.** SATI S.p.A. fattura l'imballo dei propri prodotti al prezzo di costo.
 8. **TRASPORTO.** Le condizioni di trasporto devono essere concordate tra SATI S.p.A. e il Cliente. La merce viaggia a rischio e pericolo del committente, salvo le responsabilità del vettore ai sensi dell'Art. 1693 cc.
 9. **RECLAMI.** Eventuali reclami e contestazioni sulla merce consegnata devono essere segnalati per iscritto entro 10 giorni lavorativi dal ricevimento della merce. Il trattamento da adottare per i singoli pezzi riconosciuti difettosi – compresi gli eventuali oneri economici –, e la decisione sull'intera fornitura, devono essere sempre concordate. In particolare, non si accetta l'addebito di costi di riparazione sostenuti direttamente dal Cliente, se non preventivamente autorizzati dal nostro personale interno. La presenza di materiale contestato all'interno di una fornitura non giustifica in alcun modo un ritardato o mancato pagamento dell'intera fattura relativa alla fornitura stessa.
1. **ORDERS.** SATI S.p.A. accepts only written orders. Customers shall place orders by fax, e-mail or e-commerce website and if possible they shall indicate the product codes which are to be found in the general catalogue. Once an order has been processed or packaged, it can no longer be cancelled or reduced – except in case of specific agreement with our Sales Office. The quantity of items produced according to customer's drawings can vary of $\pm 5\%$ with respect to the ordered quantity; invoices adjust accordingly.
 2. **PRICES.** Prices are agreed at the time of quotation or refer to the general price list. SATI S.p.A. reserves the faculty to modify its prices, if changes in market and production conditions make it necessary.
 3. **PROHIBITION OF ASSIGNMENT.** Contractual rights and liabilities can not be assigned to third parties with-out prior authorization from SATI S.p.A.
 4. **PAYMENT TERMS.** Payment terms shall be agreed in advance with our Sales Office. Unless authorized by our Sales Department, rounding-offs or deductions from the amounts due are not allowed. Unpaid cash orders and delayed payments determine expenses and delay interests charged to the Customer in the limits foreseen by the Italian law. Foreign bank charges related to payments are at Customer's expenses.
 5. **RETENTION OF TITLE.** Goods are subject to retention of title, until they are fully paid for, including inter-ests and accessories.
Customer's drawing or renewing (full or in part) of bills of exchange shall not be considered as extinction, novation or final payment of the price, until the full payment occurs. Similarly, drawing bills of exchange do not compromise the retention of title.
Notwithstanding the foregoing, risks of loss, failure or damage shall transfer to the Customer upon goods delivery, as stated in articles 6 and 8 of these sales terms.
 6. **DELIVERY TERMS.** Upon placement of each order, delivery terms must be arranged and reconfirmed by SATI S.p.A. Delivery terms may vary in case of production problems, difficulties in collecting material or in the event of force majeure, without affecting the validity of the order. The Customer is forced to collect items according to drawing in any case. SATI S.p.A. shall not incur any liability by reason of damages due to failed or reduced production of goods, nor for indirect and consequential damages caused by delays in the delivery of ordered goods.
 7. **PACKAGING.** SATI S.p.A. charges packaging at cost price.
 8. **TRANSPORTATION.** Transport conditions must be agreed between SATI S.p.A. and the Customer. Goods travel at the risk of the Customer, except from the carrier's liability by virtue of article 1693 of the Italian Civil Code.
 9. **CLAIMS.** Potential claims and objections on delivered goods must be reported in writing within 10 days from receipt of the goods. Decisions concerning admittedly defective goods and the entire supply these goods belong to – including economic charges – always have to be agreed upon with our Sales Office. In particular, Customer repair costs charges, unless previously authorised by our employees, are not accepted. A supply containing contested products does not justify any delay or failure of payment of the whole invoice of the supply.

10. **GARANZIA.** E' garantita la riparazione o la sostituzione dei soli pezzi riconosciuti difettosi da SATI S.p.A. Per le modalità di reso si rimanda alle modalità sotto precisate. La garanzia decade per prodotti usati in maniera difforme rispetto alle indicazioni fornite. La garanzia altresì decade per prodotti modificati, riparati, smontati anche parzialmente, oppure che siano stati conservati, installati, lubrificati o mantenuti in maniera errata o negligente. La verifica della compatibilità delle applicazioni e della correttezza degli accoppiamenti meccanici e dei collegamenti elettrici è di pertinenza e responsabilità del compratore. La garanzia non copre i materiali e le parti per loro natura soggette a deterioramento (es. perdite di lubrificante causate da normale usura degli anelli di tenuta nei riduttori venduti da SATI S.p.A.). SATI S.p.A. non assume alcuna responsabilità ed esclude il riconoscimento di qualunque tipo di indennizzo per danni che si dovessero verificare nell'impiego dei prodotti venduti, siano essi difettosi o meno. La responsabilità correlata all'applicazione di prodotti forniti è considerata in carico esclusivamente all'utilizzatore anche nei casi in cui l'applicazione sia stata consigliata da personale di SATI S.p.A. Viene infine declinata ogni responsabilità nella fornitura di particolari a disegno coperti da eventuale brevetto.
11. **RESI.** SATI S.p.A. accetta esclusivamente i resi preventivamente autorizzati dall'Ufficio Commerciale. L'autorizzazione viene comunicata al Cliente attraverso un modulo RMA che deve essere sempre citato nella documentazione di consegna della merce (fattura o documento di trasporto). Possono essere accettati resi solamente alla condizione che i prodotti siano di produzione standard (non a commessa o su specifica) e consegnati da non più di 10 giorni lavorativi (tra data di consegna e la data di richiesta autorizzazione al reso). La merce resa dovrà risultare integra e non lavorata od utilizzata dal Cliente; in caso contrario, sarà restituita al mittente con spese a Suo carico. Gli imballi della merce resa devono essere idonei onde evitare danneggiamenti durante il trasporto. Non si accettano resi di merce priva di imballi originali SATI S.p.A. ove previsti. SATI S.p.A. si riserva il diritto di addebitare un importo pari al 30% del prezzo originario di vendita a copertura dei costi di movimentazione e stoccaggio delle merci e la restituzione deve essere effettuata in porto franco. Non saranno autorizzati resi per importi inferiori a 50,00 euro per riga. Non si accettano resi entranti nei mesi di novembre e dicembre.
12. **LEGGE APPLICABILE.** Qualsiasi rapporto derivante, disciplinato o comunque collegato alle presenti condizioni generali sarà sottoposto esclusivamente alla legge italiana.
13. **FORO COMPETENTE.** Per qualsiasi controversia in materia di esecuzione, interpretazione o risoluzione di un qualsiasi rapporto derivante, disciplinato o comunque collegato alle presenti condizioni generali, sarà competente in via esclusiva il foro di Bologna, salva la facoltà di SATI S.p.A. di convenire il Cliente presso il foro territorialmente competente per il luogo in cui il medesimo Cliente ha la propria sede.
10. **GUARANTEE:** *The repair or substitution of any item is guaranteed only if SATI S.p.A. acknowledges them as defective. The return procedure is explained in the next paragraph. The guarantee is no longer valid if the products have been used in a different way than the recommended one, or if the products have been modified, repaired, tampered with, even partially disassembled or if they have been stored, installed, lubricated or maintained wrongly or carelessly. The compatibility of the product with the intended application as well as the accuracy of mechanic couplings and electrical connections must be checked under the sole buyer's responsibility. The guarantee does not cover any consumable material or part (i.e. lubricant leaks due to usual wear and tear of seals in the gearboxes sold by SATI S.p.A.). SATI S.p.A. will not be liable and excludes any indemnification for damages occurring during use of the products sold, regardless of their defectiveness. The user only shall be held liable for the applications in which the products sold by SATI S.p.A. are employed, even when the application has been recommended by SATI S.p.A. staff. Furthermore, SATI S.p.A. declines all responsibility for the supply of items made to drawing which are protected by any patent.*
11. **MATERIAL RETURN.** *SATI S.p.A. can accept exclusively the return of goods previously authorized in writing by our Sales Department. The said authorization is given to the customer by means of an RMA form, whose number shall always be mentioned in each return delivery document (invoice and/or shipping document). Only returns of standard goods (not made according to the customer's specifications) can be accepted, as well as only goods returned within 10 working days from the delivery date (10 days between delivery date and goods return request). The goods returned shall be intact and not modified or used by the Customer; if this is not the case returns will be sent back at Customer's charge. The goods shall be packed correctly to prevent any damage during transportation. Returned goods won't be accepted if not packed in original SATI S.p.A. packages, if foreseen. SATI S.p.A. reserves the right to charge the Customer with 30% of the original selling price to cover handling and stocking costs and goods shall be returned carriage paid. Returns for amounts lower than € 50,00 per each sales line won't be accepted. Returns of goods in the months of November and December are not accepted.*
12. **APPLICABLE LAW.** *Any relationship arising hereunder shall be exclusively governed by, and construed in accordance with, the Italian Law.*
13. **COURT HAVING JURISDICTION.** *All disputes concerning the execution, interpretation or termination of any relationship arising out of, regulated by, or somehow related to the terms of these general conditions, will be exclusively submitted to the judgement of the Law Court of Bologna, except if SATI S.p.A. agrees to submit them to the judgement of the Court having jurisdiction in the Customer's registered office.*

Qualora esigenze di costruzione, sviluppo evolutivo del prodotto o errori di compilazione lo rendessero necessario, SATI S.p.A. si riserva il diritto di modificare senza preavviso i contenuti di questo catalogo. In ogni caso si rimanda al sito web www.satispa.com per la consultazione dei documenti tecnici e informativi aggiornati.

SATI S.p.A. reserves the right to modify the contents of this catalogue without previous notice if made necessary by specific construction requirements, product design evolution or detection of mistakes. In any case the latest version of our technical or informative documents is always available for consultation at www.satispa.com.