



BRUSHLESS MOTOR

MINAS-BL **GV** series
KV series
GP series

Panasonic Corporation, Appliances Company, Motor Business Unit

http://industrial.panasonic.com/ww/i_e/25000/motor_fa_e/motor_fa_e.html

Compact and high-efficiency brushless motors

High-efficiency energy saving eco-friendly MINAS series* technology adopted more compact and higher-output brushless motors.

* MINAS series is a registered trademark for Panasonic AC servo motors.



•90 mm square 130 W



•60 mm square 200 W

MINAS-BL **GV** series
Speed Control Type 50 W to 130 W

MINAS-BL **KV** series
Speed Control Type 50 W to 750 W

Typical options



Console A



Digital key pad

Power Supply DC 24 V Type •80 mm square 50 W only



GV series, input voltage 24 V type made to order item. Please contact us if you'd like detailed information

Typical options



Console A



Digital key pad

MINAS-BL



•80 mm square 50 W

MINAS-BL **GP** series

Position Control Type 50 W to 130 W

Typical options



Digital key pad

Introduction	1
GV series	10
Check the model number	11
Brushless motor specifications	11
Brushless amplifier specifications	12
System configuration/ System configuration diagram	13
Parameter list of brushless amplifier	15
Brushless motors – Details	17
Gear head	23
KV series	26
Check the model number	27
Brushless motor specifications	27
Brushless amplifier specifications	28
System configuration/ System configuration diagram	29
Parameter list of brushless amplifier	33
Brushless motors – Details	35
GP series	46
Check the model number	47
Brushless motor specifications	47
Brushless amplifier specifications	48
System configuration/ System configuration diagram	49
Parameter list of brushless amplifier/ Example setting of motion pattern	51
Brushless motors – Details	57
Gear head	63
Options	66
Options – Details	67
List of peripheral equipments	74
Information	76
Guide to the international system of units (SI)	77
Selecting motor capacity	79
Conformance to international safety standards	93
Table of part numbers and options	95
Index	97
Sales office	101

Motor Business coexisting

**Panasonic Corporation, Appliances Company,
Motor Business Unit promotes preservation of
the environment together with industrial activities and
aims to “Company Coexisting with Global Environment”**

Environmental conservation activities in industrial field

Environmental conservation activities have been required widely from home level to company level nowadays, and the role of conservation in the industrial sector has become more important. Total emissions of CO₂ in 2009 in Japan were approximately 1.1 billion tons, out of which 380 million tons belong to factory and industrial field.

It has become a huge amount which significantly exceeded transportation and business sectors.

■CO₂ Emissions (2009)

Source:CO₂ Inventory Office “Japan CO₂ emission data” (Units: million tons)

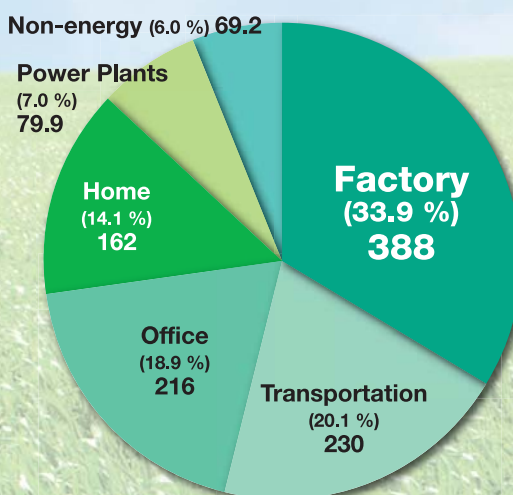

**With the spread of high-efficiency motors
that minimizes the loss of electrical energy,
We aim to achieve significant energy savings
for the entire industry.**

with Global Environment

Basic attitude

Based on "Environmental Declaration" of Panasonic, Motor Business Unit of Appliances Company also established the "Environmental Policy" as the basic attitude to environmental conservation. Based on this, we create more specific policies and manuals, and have been promoting environmental conservation activities.

Environmental Policy

Motor Business Unit of Appliances Company of Panasonic Corporation recognizes that the preservation of global environment is the important mission as a good corporate citizen of society. Our philosophy is "Coexisting with the Global Environment", and run sound business activities harmonized with nature.

Motor holds the key to global environmental protection

From small one used in mobile phones, to big one used in factories, motor has become indispensable in every aspect of our society. It has been consuming more than half part of electricity in Japan which is equal to 573 billion kWh.

■ Japan Domestic electricity consumption (2005)
Source: Motor Business Unit Research (Units: Hundred million kWh)

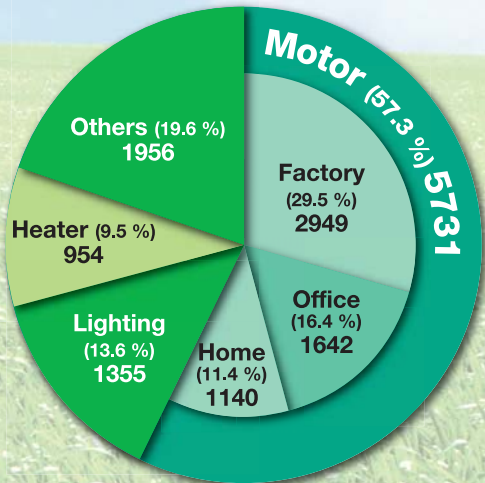

If motor power consumption reduced by 1 % (4.59 billion kWh)



Equivalent to annual one thermal power plant stop (500K kWh×8760H)



eco ideas

Panasonic is committed to the development of eco-friendly products.

Brushless motors of MINAS-BL series

Commutation brushless motor with advanced controlling technology features high efficiency and low power loss.

In addition, “Split Core Structure” developed for and proven in MINAS series AC servo motors is introduced to these new brushless motors to further reduce their sizes but increase power.

These motors promote “three saving” activities – Energy saving, Cost saving and Space saving.



GV KV GP Reduce loss and increase efficiency

A permanent magnet on a rotor reduces secondary loss. It also reduces power consumption by 20 % compared with those of our small geared motors.

■ Comparison of input power with our conventional motors (90 W)

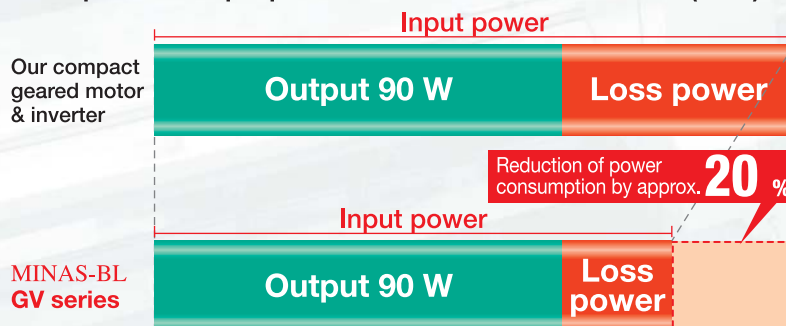

Energy saving effects are significantly seen when these new models are used on multi-axis machines, e.g. textile machinery.

MINAS-BL series Provide More Features

GV GP

Speed control range **30** r/min ~ **4000**^{*1} r/min
 Proprietary CS sensor for sinewave driving
Wide 1:133 variable speed range

*1 Rated rotational speed: 3000 r/min

GV KV GP

Start torque **150** % (comparison of rated values)
 Unlike induction motor
Stable operation startup at lower speed

GV KV GP

Flat torque characteristic

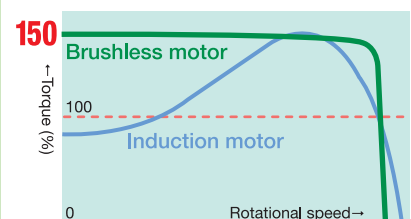

Proprietary CS sensor for **Smooth operation**

realize “Three Savings”.

Space Saving

GV KV GP For simultaneous pursuit of miniaturization and high power

“Split core structure” developed for and proven in MINAS series AC servo motors is introduced to these new models to significantly reduce size and weight but increase output power compared with induction motors.

■ Comparison in size between GV/GP series and our compact geared motors (90 W)

Reduction in profile by approx. 55 %

■ Comparison in mass between GV/GP series and our compact geared motors

Lighter by approx. 1/3



▲ Split core structure

Our compact geared motor 90 W (90 mm square)

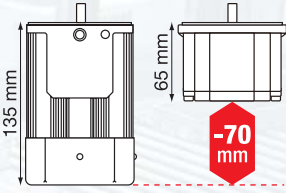

MINAS-BL GV/GP series 90 W (90 mm square)

Output	GV/GP series (motor)	Our compact geared motor
50 W	0.7 kg	2.4 kg(40 W)
90 W	1.0 kg	3.2 kg
130 W	1.2 kg	—

● The size of a GV/GP series brushless amplifier is almost equal to that of a postcard and weights approx. 370 g.

Comparison of KV series with general purpose induction motors: **Approx. 1/7 in volume and approx. 1/4 in mass**

Enable downsizing of embedded device.

Cost Saving

GV KV GP They also reduce maintenance and setup cost.

Commutatorless and brushless design reduces associated costs such as maintenance cost. Our setup support software helps prompt startup and reduction in operation management process.

■ Setup support software PANATERM for BL



▲ Parameter setting
File saving (Batch reading/writing)

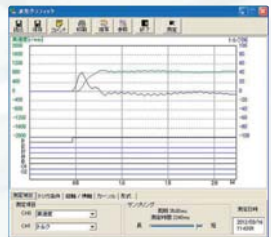

▲ Waveform graphical display
Example: Velocity and torque
Status of I/O can also be monitored.

The PANATERM for BL allows easy setup of parameters. Waveform graphical display can be used for precisely and accurately monitoring motor conditions, reducing setup and maintenance workload.

GV KV

8-speed operation

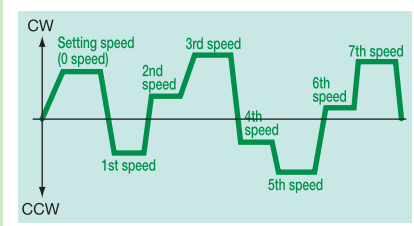

Stable operation maintains high productivity and yield ratio.
The speed is regulated at 0.5 % or less variation.

*2 Within rated torque

GP

Positioning at 4 points

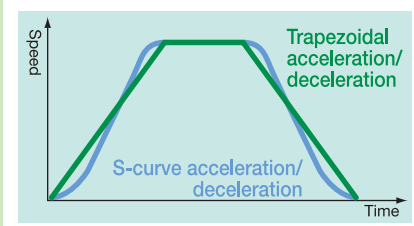

Not only trapezoidal waveform, **S-curve acceleration/deceleration can be set.**

(Under application)
GV KV GP

Compatible with international standards



Compatible with wider power source voltage range

(Single-phase: 100 V -120 V
Single-/Three-phase: 200 V -240 V)

Speed Control Type

GV series KV series



•90 mm square 130 W

MINAS-BL **GV** series
Speed Control Type 50 W to 130 W



•60 mm square 200 W

MINAS-BL **KV** series
Speed Control Type 50 W to 750 W

- High efficiency brushless motors realize energy saving.
- Distinctively controlled CS signal provides smooth operation through sinewave driving.
- Compatible with international standards, CE, UL, CCC and KC (KV series will also be compatible with the standards in the near future), and wider power source voltage range.
- The digital keypad (sold separately) and setup support software PANATERM for BL (available from our website, free of charge) enable parameter setting and monitoring.
- The proprietary CS sensor extends variable speed control range.
- Installation compatibility: GV series is compatible with our compact geared motors
KV series is compatible with our AC servo motors
- Environmental protection: IP65

Typical applications

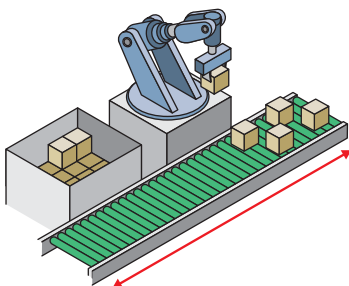

Conveyer

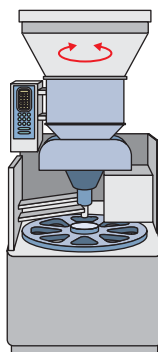

Food processor (agitating)

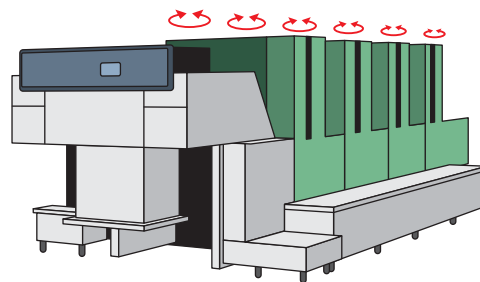

Textile machinery

Position Control Type GP series



•80 mm square 50 W

MINAS-BL GP series Position Control Type 50 W to 130 W

- Simple NC function enables easier positioning without help of a pulse unit.
- The proprietary CS sensor enables positioning without help of an external encoder.
- Compatible with international standards (CE, UL, CCC and KC), and wider power source voltage range.
- Internal teaching capability simplifies positioning operation.
- The digital keypad (sold separately) and setup support software PANATERM for BL (available from our website, free of charge) enable parameter setting and monitoring.
- Installation is compatible with our compact geared motors.
- Environmental protection: IP65

Typical applications

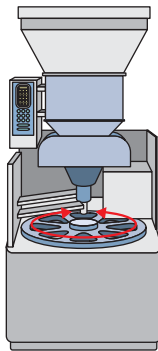

Food processor (turntable)

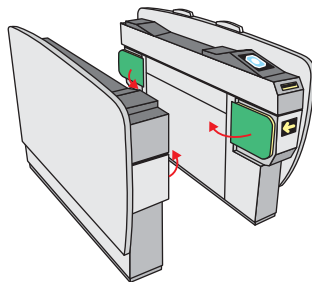

Automatic ticket gate

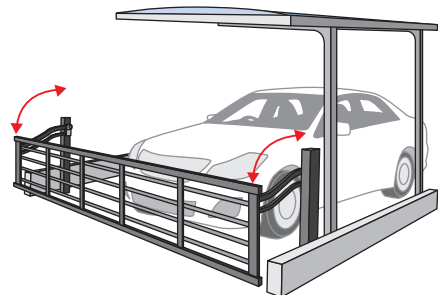

Gate

MEMO

A series of horizontal dashed lines for writing.

MINAS-BL **GV** series

Speed Control Type 50 W to 130 W

GV series



• 90 mm square 130 W

Contents

Check the model number	11
Brushless motor specifications	11
Brushless amplifier specifications	12
System configuration/ System configuration diagram	13
Parameter list of brushless amplifier	15
Brushless motors – Details	17
Gear head	23

Check the model number

<Motor>

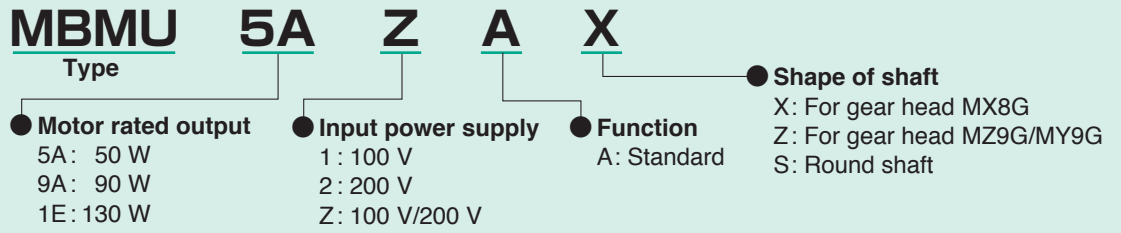

<Gear head>

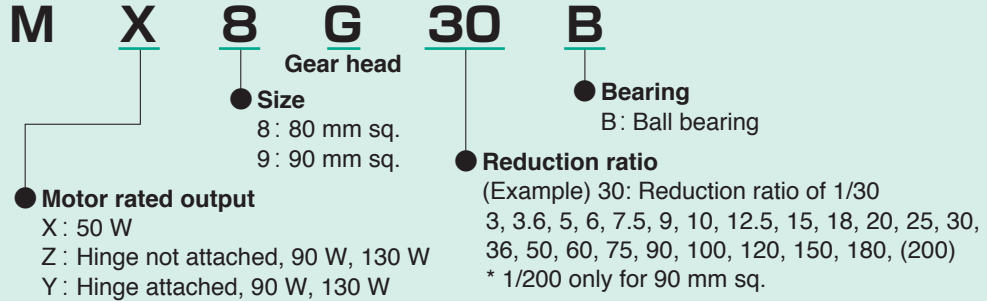

Brushless motor specifications

Item	Specifications				
Flange size	80 mm sq.	90 mm sq.			
Motor model No. ^{*1}	MBMU5AZA ○	MBMU9A1A ○	MBMU9A2A ○	MBMU1E1A ○	MBMU1E2A ○
Motor rated output (W)	50	90		130	
Voltage (V)	for 100/200	for 100	for 200	for 100	for 200
Rated torque (N·m)	0.16	0.29		0.41	
Starting torque ^{*2} (N·m)	0.24	0.43		0.62	
Rated input current (A(rms))	0.53	1.00	0.50	1.30	0.72
Moment of inertia of rotor (×10 ⁻⁴ kg·m ²)	0.12	0.27		0.36	
Rating	Continuous				
Rated rotation speed ^{*3} (r/min)	3000				
Speed control range (r/min)	30 to 4000				
Ambient temperature	-10 ℃ to +40 ℃ (free from freezing) * Ambient temperature is measured at a distance of 5 cm from the motor.				
Ambient humidity	20 % to 85 % RH (free from condensation)				
Altitude	Lower than 1000 m				
Vibration	4.9 m/s ² or less X, Y, Z				
Motor insulation class	130(B) (UL certified 105 (A))				
Protection structure	IP65 ^{*4,5}				
Number of poles	8				
Motor mass (kg)	0.7	1.0		1.2	

*1 Suffix of "○" in the motor model represents shape of shaft.

*2 Representative value

*3 Motor shaft speed: to be multiplied by the reduction ratio when the gear head is used.

*4 Excluding the shaft pass-through section and cable end connector.

*5 These motors conform to the test conditions specified in EN standards (EN60529, EN60034-5).

Do not use these motors in application where water proof performance is required such as continuous wash-down operation.

<Brushless amplifier>

MBEG

5A

5

B

C

V

Type

● **Motor rated output**

5A : 50 W
9A : 90 W
1E : 130 W

● **Function 1**

B: with circuit for regenerative resistor

● **Input power supply**

1: Single phase AC100 V to 120 V
5: Single phase/ 3-phase AC200 V to 240 V

● **Function 2**

C: RS485 communication, Signal input/Sink type (NPN transistor)
D: RS485 communication, Signal input/Source type (PNP transistor) Source type made to order item. Please contact us if you'd like detailed information.

● **Control mode**
V: speed control

Brushless amplifier specifications (GV series)

Item	Specifications									
Amplifier model No.	MBEG5A1BCV	MBEG5A5BCV			MBEG9A1BCV	MBEG9A5BCV		MBEG1E1BCV	MBEG1E5BCV	
Applicable Motor ^{*1}	MBMU5AZA○			MBMU9A1A○	MBMU9A2A○		MBMU1E1A○	MBMU1E2A○		
Motor rated output (W)	50			90			130			
Input power supply voltage (V)	Single phase 100 to 120	Single phase	3-phase	Single phase 100 to 120	Single phase	3-phase	Single phase 100 to 120	Single phase	3-phase	
		200 to 240			200 to 240			200 to 240		
Frequency (Hz)	50/60									
Rated input current (A)	1.5	0.7	0.35	2.2	1.1	0.5	2.8	1.5	0.7	
Voltage tolerance	±10 %									
Control method	Speed control by CS signal, PWM sine wave driving system									
Ambient temperature	0 ℃ to +50 ℃ (free from freezing) * Ambient temperature is measured at a distance of 5 cm from the amplifier.									
Ambient humidity	20 % to 85 % RH (free from condensation)									
Location	Indoor (No corrosive gas, A place without garbage, and dust)									
Altitude	Lower than 1000 m									
Vibration	5.9 m/s ² or less (10 Hz to 60 Hz)									
Protection structure/ Cooling system	Equivalent to IP20/ Self cooling									
Storage temperature	Normal temperature * Temperature which is acceptable for a short time, such as during transportation is -20 ℃ to 60 ℃ (free from freezing)									
Storage humidity	Normal humidity									
Rated rotation speed	3000 r/min									
Speed control range	30 r/min to 4000 r/min (Speed ratio 1:133)									
Speed fluctuation factor	With load	±0.5 % or below (at 0 to Rated torque, Rated rotation speed)								
	With voltage	±0.5 % or below (at supply voltage ±10 %, rated rotation speed)								
	With temperature	±0.5 % or below (at 0 °C to 50 °C, rated rotation speed)								
Acceleration/ Deceleration time	0.01 sec to 300 sec (time for changing 1000 r/min) ^{*2}									
Stopping procedure	Slowdown stop/ Free-run stop ^{*2}									
Speed setting	0 r/min to 4000 r/min (analogue voltage (0 V to 5 V), console A), 0 r/min to 4000 r/min (Setting selection by parameter on Digital key pad)									
Speed setting resolution	Analog: approx. 1/200 of upper speed limit Digital: 1 r/min									
Speed setting precision (at 20 °C)	Analog: ±3 % or below of upper speed limit (±90 r/min or below at upper speed limit 3000 r/min) [Digital: 1 % or below of upper speed limit]									
Operation mode	8 speed									
Signal input	5 inputs ^{*2} (run/ stop, CW run/ CCW run, multi function 3bit)									
Signal output	2 outputs (Open collector) ^{*2} (Trip output etc)									
Communication function	RS485	Max 31 units. Setting of parameter, monitoring of control condition. Communication speed: Choose from 2400 bps/ 4800 bps/ 9600 bps								
	RS232	Setting of parameter and monitoring of control condition are enabled with commercial PC. ^{*3}								
Digital key pad	Setting of parameter, monitoring of control condition. ^{*4}									
Protective function	Warning : Undervoltage ^{*2} , Overload warning, setting change warning Protect : Undervoltage ^{*2} , Overload, Overcurrent, Overvoltage, Overheat, Overspeed, Sensor error, RS485 communication error, External forced trip error, User parameter error, CPU error									
Regenerating brake	Regenerative braking resistor can be externally connected. ^{*5} Instantaneous braking torque 150 %, Continuous regenerative power 10 W (Regenerative operation with which motor shaft is rotated by load, e.g. load lowering operation, should not be continued.)									
Protection level	Overload protection: 115 %, Time characteristics: 150 % 60 sec									
Amplifier mass (kg)	0.37									

*1 Suffix of "○" in the motor model represents shape of shaft. *2 Can be changed from PANATERM for BL or Digital key pad.

*3 PANATERM for BL (Download from our web site.), PC connection cable (DV0P4140), Digital key pad connection cable (DV0P383*0) is required. If your PC does not have RS232 port, use RS232-USB converter.

*4 Digital key pad connection cable (DV0P383*0) is required. *5 Use optional external regenerative resistor (sold separately).

System configuration

Power supply	Rated rotation speed (r/min)	output (W)	Motor	Gear head (Note 1)	Brushless amplifier	Brushless amplifier (supplied with power cable) (Note 2)	Optional parts				
							External regenerative resistor	Noise filter	Surge absorber	Reactor	
						Reference page	p. 74	p. 71	p. 67	p. 67	p. 73
Single phase 100 V	3000	50	MBMU5AZAX	MX8G□B	MBEG5A1BCV	MBEG5A1BCVC	for 100 V DV0P2890	for single phase power supply DV0P4170	for single phase power supply DV0P4190	for single phase power supply DV0P227	
			MBMU5AZAS	—							
		90	MBMU9A1AZ	MZ9G□B MY9G□B	MBEG9A1BCV	MBEG9A1BCVC					
			MBMU9A1AS	—							
		130	MBMU1E1AZ	MZ9G□B MY9G□B	MBEG1E1BCV	MBEG1E1BCVC					
			MBMU1E1AS	—							
Single/3-phase 200 V	3000	50	MBMU5AZAX	MX8G□B	MBEG5A5BCV	MBEG5A5BCVC	for 200 V DV0PM20068	for single phase power supply DV0P4170 for 3-phase power supply DV0PM20042	for single phase power supply DV0P4190	for 3-phase power supply DV0P1450	
			MBMU5AZAS	—							
		90	MBMU9A2AZ	MZ9G□B MY9G□B	MBEG9A5BCV	MBEG9A5BCVC					
			MBMU9A2AS	—							
		130	MBMU1E2AZ	MZ9G□B MY9G□B	MBEG1E5BCV	MBEG1E5BCVC					
			MBMU1E2AS	—							

(Note 1) A figure representing reduction ratio in □ .

(Note 2) Refer to p. 74 for a power supply connecting cable.

This part number is the ordering part number for the amplifier and power cable, not for ordering amplifier only.

* When installing the reactor, refer to p. 73.

- * Be sure to use a set of matched components (series, power source, capacity, output, etc.)
- * This motor is not provided with a holding brake. If it is used to drive a vertical shaft, the movable section may fall down by its own weight as power is turned off.

Options

Optional parts	Parts number	Reference page	Optional parts	Parts number	Reference page	
Motor extension cable	1 m	DV0PQ1000110	Digital key pad connection cable	1 m	DV0P38310	
	3 m	DV0PQ1000130		3 m	DV0P38330	
	5 m	DV0PQ1000150		5 m	DV0P38350	
	10 m	DV0PQ10001A1		External speed setter	DV0PM20078	P.71
Power supply connector kit	DV0P2870	P.70	Control signal cable	2 m	DV0PM20076	P.70
Console A ¹	DV0P3500	P.68	I/O connector kit	DV0PM20070	P.71	
Console A connection cable	1 m	DV0PM2006910	Panel connector kit	DV0P3610	P.71	
	3 m	DV0PM2006930	PC connection cable ³	1.5 m	DV0P4140	P.70
	5 m	DV0PM2006950	Noise filter for signal line	DV0P1460	P.67	
Digital key pad ²	DV0P3510	P.68	DIN rail mounting unit	DV0P3811	P.72	

* For details of cable, refer to p. 68 to 70.

*1 When using Console A, the Console A connection cable (DV0PM20069*0) is required.

*2 When using Digital key pad, the Digital key pad connection cable (DV0P383*0) is required.

*3 When connecting PC, the PC connection cable (DV0P4140) and the Digital key pad connection cable (DV0P383*0) are required.

Wiring equipment

Selection of circuit breaker (MCCB), magnetic contactor and electric wire. (To check conformity with international standards, refer to p. 93 Conformity with international safety standards.)

Voltage	Power capacity	MCCB Rated current	Magnetic contactor Rated Current (Contact composition)	Core of electric wire (mm ²)	
				Main circuit, Grounding	Control circuit
Single phase 100 V	50 W to 130 W	5 A	20 A (3P+1a)	0.5 (AWG20)	0.13 (AWG26)
Single phase 200 V					
3-phase 200 V					

Be sure to connect the earth terminal to ground.

In wiring to power supply (outside of equipment) from MCCB, use an electric wire of 1.6 mm diameter (2.0 mm²) or more both for main circuit and grounding. Apply grounding class D (100 Ω or below) for grounding.

Selection of relay

A relay used in a control circuit, e.g. at the control input terminal should be small signal relay (Min. guaranteed current 1 mA or less) for positive contact.

Example: Panasonic: DS, NK or HC series, OMRON: G2A series

Selection of control circuit switch

When using a switch in place of relay, select a switch rated at minute electric current, to assure positive contact.

Example: Nihon Kaiheiki Ind.: M-2012J-G

System configuration diagram

● Example of analog setting (Console A)

- Set the speed with the speed setting knob (variable resistor).
- Start/stop the motor from the RUN/STOP switch.
- To change rotating direction, use the rotation direction selector switch.

● When not using Console A

Motor controls such as start/stop, direction change and speed setting can be done from external potentiometer and switch through optional control signal cable or I/O connector kit.

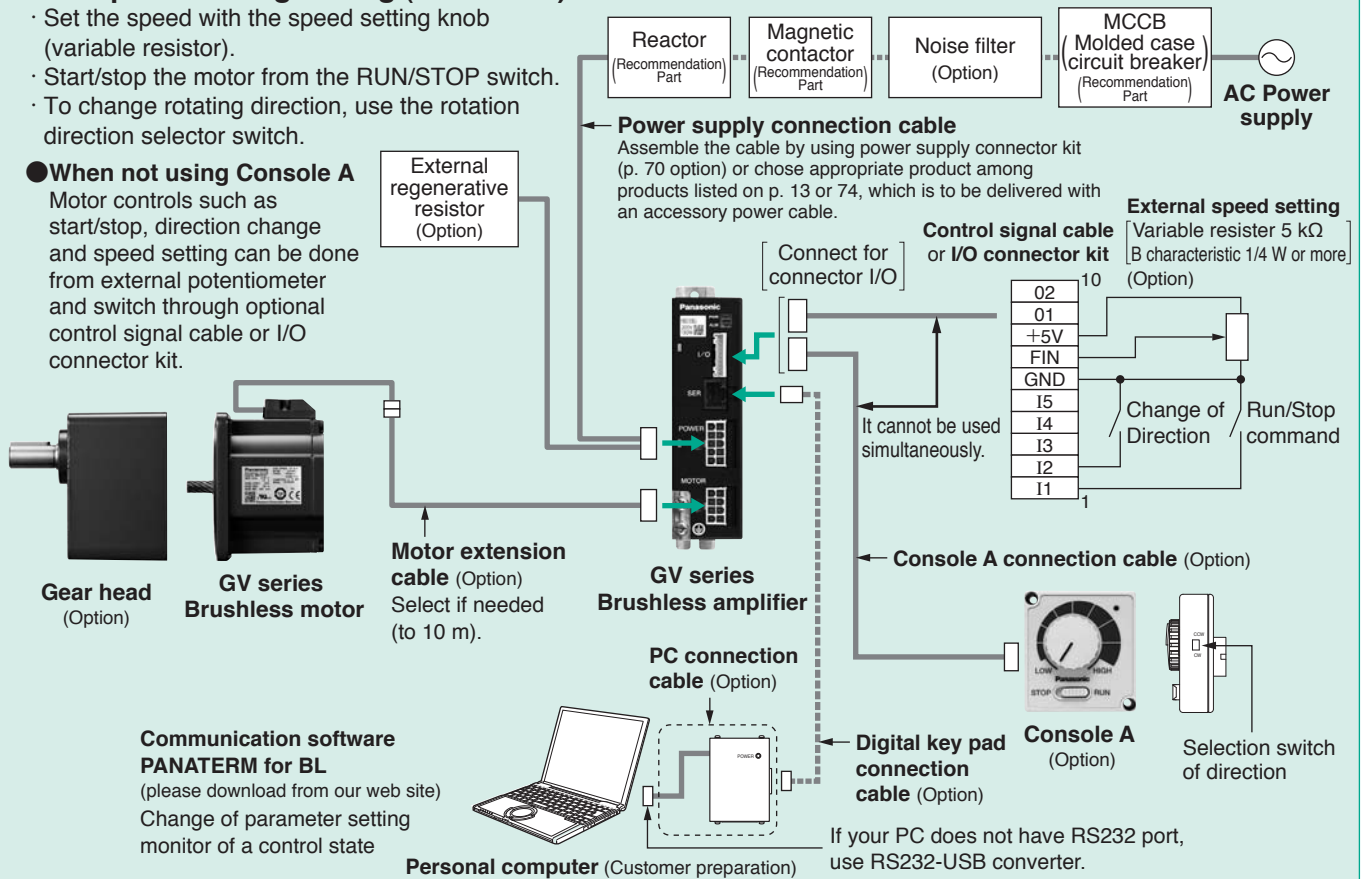

● Example of digital setting (Digital key pad)

- Digital monitor (speed, torque, voltage)
- To start/stop the motor, use RUN/STOP key
- Set/change parameters

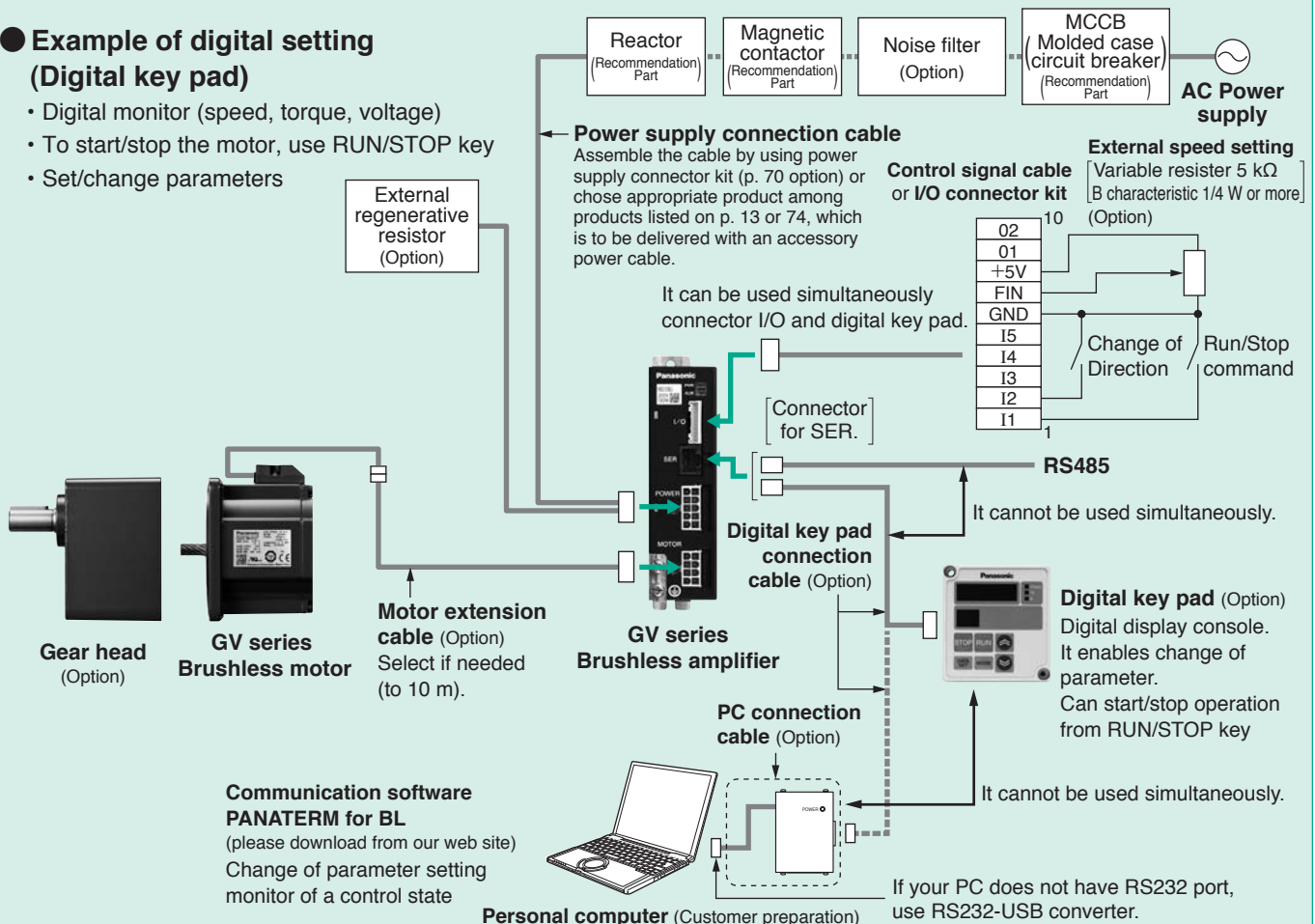

Parameter list of brushless amplifier

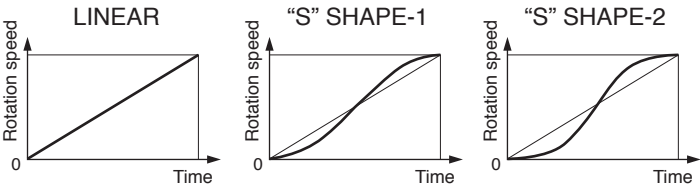
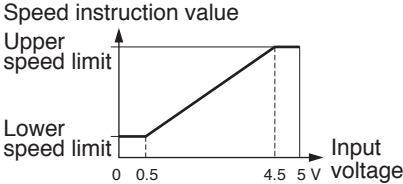
Parameter No.	Parameter name	Explanation	Setting range																												
00	Internal speed (0-th speed)	Desired running speed can be set with the Digital key pad.	0 r/min to Upper speed limit [Minimum unit 1 r/min]																												
01 to 07	1st speed to 7th speed	Speed in multi-speed running can be set.	0 r/min to Upper speed limit [Minimum unit 1 r/min]																												
10 11	1st acceleration time 2nd acceleration time	The change factor of output speed in acceleration can be determined. Set by time for changing 1000 r/min.	0.01 sec to 300 sec to 3 sec: Incremented by 0.01 second 3 sec to 30 sec: Incremented by 0.1 second 30 sec to 300 sec: Incremented by 1 second																												
12 13	1st deceleration time 2nd deceleration time	The change factor of output speed in deceleration can be determined. Set by time for changing 1000 r/min.																													
14 15	Acceleration mode selection Deceleration mode selection	Straight line acceleration/deceleration and curve (S-shape) acceleration and deceleration can be chosen individually for acceleration and deceleration. 	Select S-shape when "31 Speed command selection" is PnL.																												
16	Stop mode selection	You can select how to stop the motor when stop command is input: free-run stop or stop after deceleration.																													
17	Free-run waiting time	When the stop mode is set to deceleration stop, the zero speed (servo lock time) after deceleration can be adjusted.	0.0 sec to 10.0 sec [Minimum unit 0.1 sec]																												
1A	Velocity loop proportional gain	Enables setting of proportional gain of velocity amplifier.	0 to 10000 [Minimum unit 0.1]																												
1b	Velocity loop integration gain	Enables setting of integration gain of velocity amplifier.	0 to 10000 [Minimum unit 0.1]																												
30	Run command selection	Run command can be applied through: Digital key pad, input terminal "I1", "I2" or RS485 communication, whichever selected.																													
31	Speed command selection	You can choose whether to use "00 Internal speed (0-th speed)" or analog input terminal for speed command.																													
32	Operation mode selection	Parameter for choosing operation mode <table border="1" data-bbox="448 1346 1139 1662"> <thead> <tr> <th rowspan="2">Setting</th> <th rowspan="2">Operation mode</th> <th colspan="3">Function of signal input</th> </tr> <tr> <th>I3</th> <th>I4</th> <th>I5</th> </tr> </thead> <tbody> <tr> <td>1</td> <td>1st speed operation mode</td> <td></td> <td colspan="2">Free-run stop External forced trip</td> </tr> <tr> <td>2</td> <td>2nd speed operation mode</td> <td>Speed setting</td> <td colspan="2">2nd Acc./Dec. time Trip reset</td> </tr> <tr> <td>4</td> <td>4th speed operation mode</td> <td>Speed setting</td> <td>Speed setting</td> <td></td> </tr> <tr> <td>8</td> <td>8th speed operation mode</td> <td>Speed setting</td> <td>Speed setting</td> <td>Speed setting</td> </tr> </tbody> </table>	Setting	Operation mode	Function of signal input			I3	I4	I5	1	1st speed operation mode		Free-run stop External forced trip		2	2nd speed operation mode	Speed setting	2nd Acc./Dec. time Trip reset		4	4th speed operation mode	Speed setting	Speed setting		8	8th speed operation mode	Speed setting	Speed setting	Speed setting	
Setting	Operation mode	Function of signal input																													
		I3	I4	I5																											
1	1st speed operation mode		Free-run stop External forced trip																												
2	2nd speed operation mode	Speed setting	2nd Acc./Dec. time Trip reset																												
4	4th speed operation mode	Speed setting	Speed setting																												
8	8th speed operation mode	Speed setting	Speed setting	Speed setting																											
33 34 35 36	I1/I2 function selection I3 function selection I4 function selection I5 function selection	Signal input functions I1 to I5 can be individually selected.	Free-run stop External forced trip 2nd Acc./Dec. time Trip reset																												
3A	Lower speed limit	When speed command selection is set to analog, set the motor speed at 0 V input. 	0 r/min to Upper speed limit [Minimum unit 1 r/min]																												
3b	Upper speed limit	Upper limit of motor command speed.	0 r/min to 4000 r/min [Minimum unit 1 r/min]																												
3C	Torque limit	Upper limit of motor output torque is set.	50 % to 150 % [Minimum unit 1 %]																												

Parameter No.	Parameter name	Explanation	Setting range
40 41	O1 function selection O2 function selection	The type of signals from output terminals "O1" and "O2" can be selected. * Do not use it for position detector and positioning.	Trip: ON, Speed is reached to a command value: ON, Running: ON, Free run: ON, CCW run: ON, CW run: ON, Load exceeds 100 %: ON, Speed pulse signal*
42 43	O1 output polarity selection O2 output polarity selection	This is a function for inverting the polarity of signal output terminal O1 and O2.	
44	Speed matching range	"Matching range" of arriving signal can be adjusted.	20 r/min to Upper speed limit [Minimum unit 1 r/min]
45	Output pulse count selection	Set the number of pulses to be output to output terminals "O1" and "O2". • When you use it in more than 3000 r/min, choose values less than 12. • Do not use "the speed pulse" of the output signal (parameter No.45) for position sensing and a positioning use.	1, 2, 3, 4, 6, 8, 12, 24
46	Monitor mode selection	You can choose description to be displayed on 5-digit LED when turning on power.	Rotation speed, Speed command, Internal DC voltage, Load factor, Torque
47 48	Numerator of display magnification factor Denominator of display magnification factor	By setting the multiplying factor of a value displayed on 5-digit LED, the rotation speed of gear output shaft and conveyor speed can be displayed.	
4A	Trip history clear	Trip history can be cleared.	
4b to 4F	Trip history 1 to Trip history 5	Trip history for 5 times in the past is stored.	
50	Undervoltage trip selection	You can select whether tripping occurs upon detection of undervoltage.	
51	Retrial selection	Automatic reset in trip (trip retrial) can be set here.	
52	Retrial start time	You can set waiting time until retrial operation is performed after tripping is found.	1 sec to 120 sec [Minimum unit 1 r/min]
54	Parameter initializing	Parameters can be initialized to the factory default.	
57	Parameter copy	Parameters can be copied.	
5A	RS485 device number	Set the device number of Amplifier in communication (Amplifier ID)	
5b	RS485 communication speed	Set the communication speed of RS485 communication.	
5C	RS485 communication standard	Set the communication standard of RS485 communication.	
5d	RS485 communication response time	You can set the shortest time necessary to set the RS485 bus to transmission mode to response upon receiving communication data.	
5E	RS485 retry times of communication	Set the retry times of RS485 communication.	
5F	RS485 protocol timeout	You can set the permissible time interval between successively received character codes.	

GV series

KV series

GP series

Options

Information

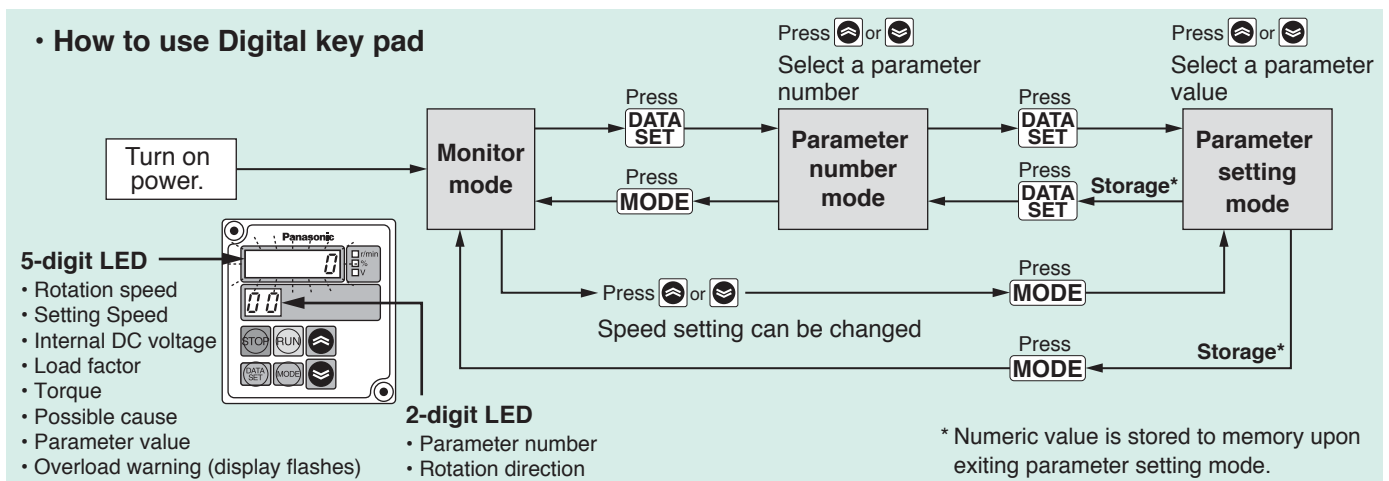

MINAS-BL GV series

■ Specification (For Common specification, see p. 11, 12)

Size	Model No. / Amplifier and Motor		Rated output (W)	Input power supply for Amplifier			Rated torque (N·m)	Starting torque (N·m)	Rated speed (r/min)	Maximum rotation speed (r/min)	
	Brushless Amplifier	Motor		Voltage AC (V)	Allowed range (%)	Frequency (Hz)					Rated input current (A)
80 mm sq.	MBEG5A1BCV	MBMU5AZA○	50	Single phase 100 to 120	±10	50/60	1.5	0.16	0.24	3000	4000
	MBEG5A5BCV	MBMU5AZA○		Single phase 200 to 240			Single phase 0.7				

* Suffix of "○" in the motor model No. represents shape of shaft.

* Starting torque: Representative value

■ Permissible torque at output shaft of gear head (N·m)

Applicable Gear head	Reduction ratio	Reduction ratio																							
		3	3.6	5	6	7.5	9	10	12.5	15	18	20	25	30	36	50	60	75	90	100	120	150	180		
MX8G□B	motor rotation speed (r/min)	3000 or less	0.39	0.46	0.64	0.77	0.96	1.16	1.29	1.61	1.92	2.33	2.59	3.23	3.61	4.33	5.93	7.29	7.84						
		3000 to 4000	0.29	0.35	0.48	0.58	0.72	0.87	0.97	1.21	1.44	1.75	1.94	2.42	2.71	3.25	4.45	5.47	6.84	7.84					
	Rotational direction	Same as motor rotational direction												Reverse to motor rotational direction											

■ Permissible load inertia moment ($\times 10^{-4} \text{ kg} \cdot \text{m}^2$)

Reduction ratio	3	3.6	5	6	7.5	9	10	12.5	15	18	20	25	30	36	50	60	75	90	100	120	150	180
Applicable Gear head																						
MX8G□B	1.25	1.79	3.42	4.90	7.72	11.2	13.8	21.6	30.6	45.2	55.8	86.9	127	183	342							

■ Permissible shaft load

Motor and Gear head

Overhung load (W)

Thrust load (F)

Attachment side

		Overhung load (W)	Thrust load (F)
Motor shaft (Round shaft)	Output	100 N	10 N
	50 W		
Applicable Gear head	MX8G□B	294 N	49 N

■ Wiring diagram

• In Case of 3-Phase 200 V

*When you use single phase, connect the main power between L1 and L2 terminals.

Power supply input

MCCB (Molded case circuit breaker)

Noise filter

External regenerative resistor

Connector for control signals (I/O)

External speed setting Variable resistor 5 kΩ B characteristic 1/4 W

Change of Direction

Run/Stop command

Please refer to P.69 for the wiring of the motor extension cable.

Be sure to ground the grounding terminal.

In wiring to power supply (outside of equipment) from MCCB, use an electric wire of 1.6 mm diameter (2.0 mm²) or more both for main circuit and grounding. Apply grounding class D (100 Ω or below) for grounding. Do not tighten the ground wires together, but connect them individually.

■ Speed-torque characteristic (Dotted line shows a characteristic curve when supply voltage drops by 10 %.)

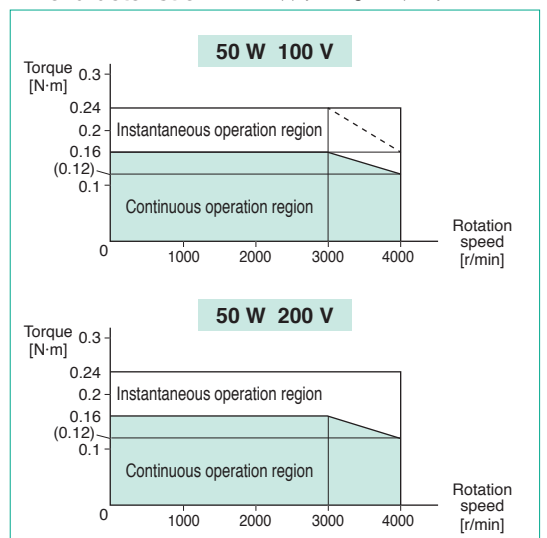

* Before using, be sure to read "Instruction manual" to check precautions and correct procedure.

Motor (dimensions)

Unit mm

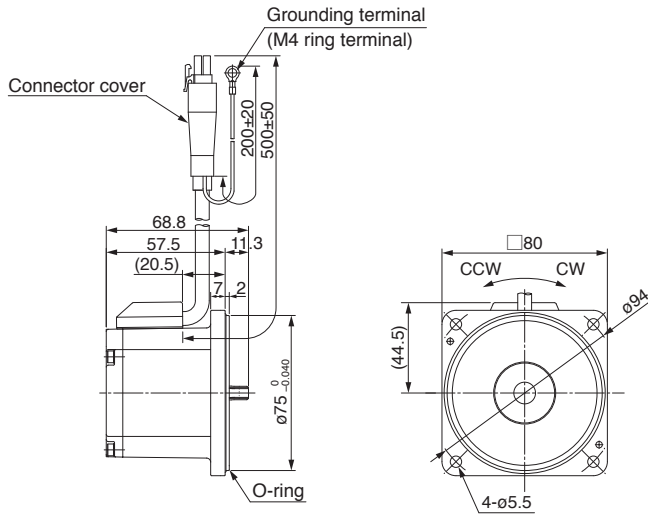

<Round shaft type>

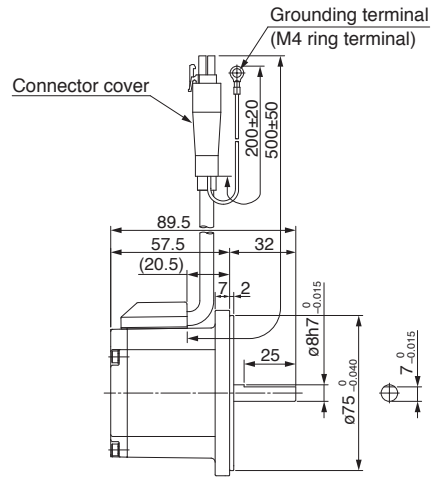

mass
0.7 kg

Gear head (dimensions)

Unit mm

MX8G□B

mass
0.6 kg

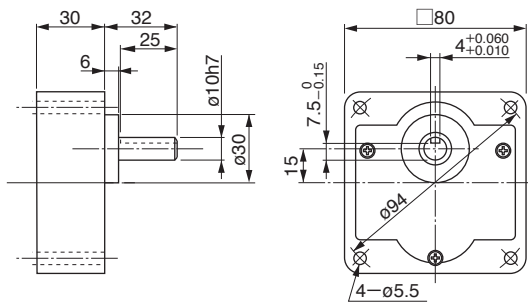

<Key and keyway [attachment]>

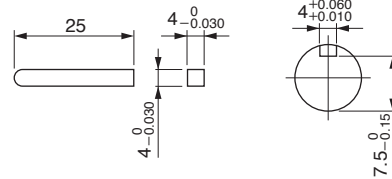

Brushless amplifier (dimensions)

Unit mm

mass
0.37 kg

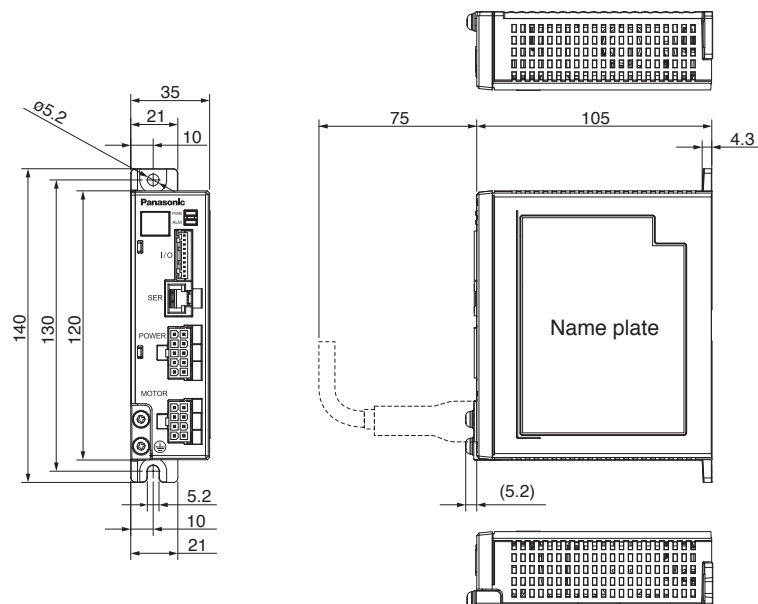

<Cautions> Dimensions are subject to change without notice. Contact us or a dealer for the latest information.

MINAS-BL GV series

Specification (For Common specification, see p. 11, 12)

Size	Model No. / Amplifier and Motor		Rated output (W)	Input power supply for Amplifier			Rated torque (N·m)	Starting torque (N·m)	Rated speed (r/min)	Maximum rotation speed (r/min)
	Brushless Amplifier	Motor		Voltage AC (V)	Allowed range (%)	Frequency (Hz)				
90 mm sq.	MBEG9A1BCV	MBMU9A1A○	90	Single phase 100 to 120	±10	50/60	0.29	0.43	3000	4000
	MBEG9A5BCV	MBMU9A2A○		Single phase 200 to 240						

* Suffix of "○" in the motor model No. represents shape of shaft.

* Starting torque: Representative value

Permissible torque at output shaft of gear head (N·m)

Applicable Gear head	Reduction ratio	Reduction ratio																								
		3	3.6	5	6	7.5	9	10	12.5	15	18	20	25	30	36	50	60	75	90	100	120	150	180	200		
MZ9G□B MY9G□B	motor rotation speed (r/min)	3000 or less	0.67	0.81	1.12	1.34	1.69	2.02	2.28	2.54	3.06	3.72	4.11	5.27	6.22	6.96	9.81	11.7	14.7	17.3	19.0	19.6				
	3000 to 4000	0.50	0.61	0.84	1.01	1.27	1.52	1.71	1.91	2.30	2.79	3.08	3.95	4.67	5.22	7.36	8.78	11.0	13.0	14.3	17.0	19.6				
Rotational direction		Same as motor rotational direction										Reverse to motor rotational direction					Same as motor rotational direction									

Permissible load inertia moment ($\times 10^{-4} \text{ kg} \cdot \text{m}^2$)

Reduction ratio	3	3.6	5	6	7.5	9	10	12.5	15	18	20	25	30	36	50	60	75	90	100	120	150	180	200	
Applicable Gear head																								
MZ9G□B / MY9G□B	5.93	8.47	16.4	23.6	37.3	53.4	67.6	98.3	142	211	257	423	589	847	1684									

Permissible shaft load

		Overhung load (W)	Thrust load (F)
Motor shaft (Round shaft)	Output	150 N	20 N
	90 W		
Applicable Gear head	MZ9G□B / MY9G□B	588 N	147 N

Wiring diagram

In Case of 3-Phase 200 V

*When you use single phase, connect the main power between L1 and L2 terminals.

Connector for control signals (I/O)

02	10
01	
+5V	
FIN	
GND	
15	
14	
13	
12	
11	

External speed setting Variable resistor 5 kΩ B characteristic 1/4 W

Change of Direction Run/Stop command

Please refer to P.69 for the wiring of the motor extension cable.

Be sure to ground the grounding terminal.

In wiring to power supply (outside of equipment) from MCCB, use an electric wire of 1.6 mm diameter (2.0 mm²) or more both for main circuit and grounding. Apply grounding class D (100 Ω or below) for grounding. Do not tighten the ground wires together, but connect them individually.

Speed-torque characteristic (Dotted line shows a characteristic curve when supply voltage drops by 10 %)

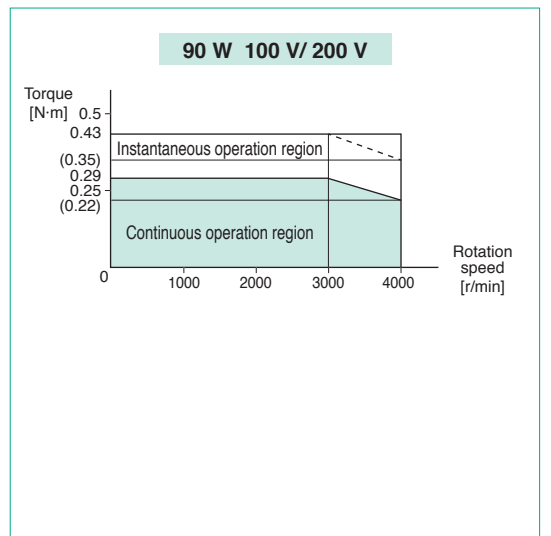

* Before using, be sure to read "Instruction manual" to check precautions and correct procedure.

Motor (dimensions)

Unit mm

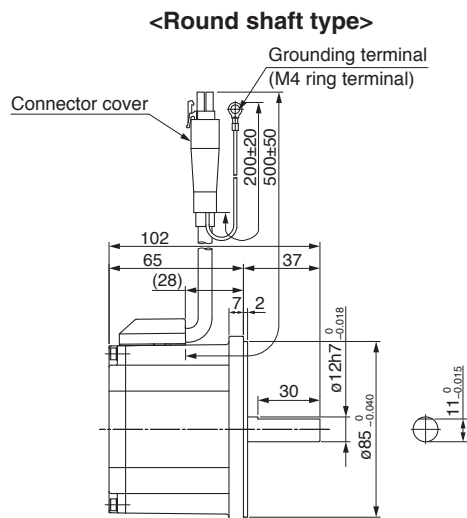
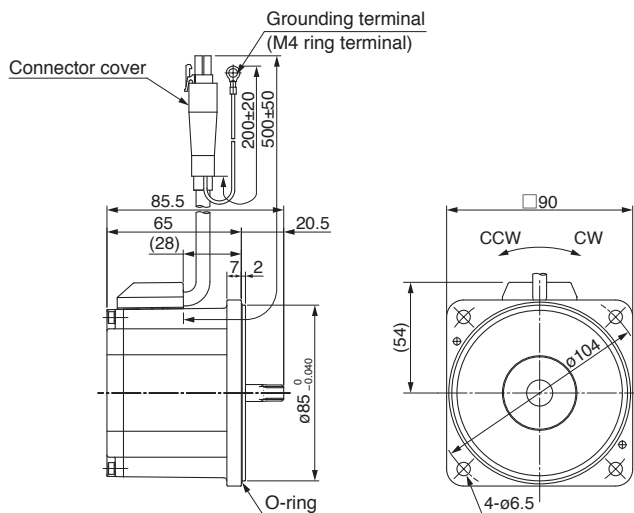

mass
1.0 kg

Gear head (dimensions)

Unit mm

MZ9G□B (Ball bearing/Hinge not attached)

mass
1.4 kg

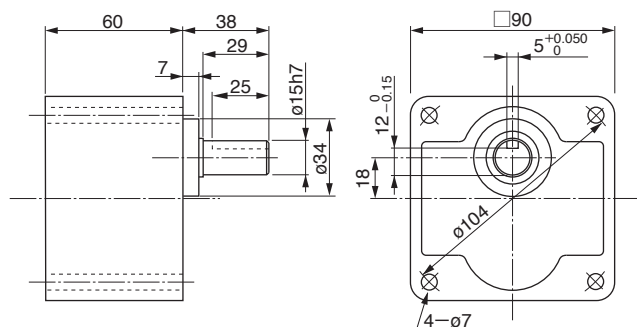

MY9G□B (Ball bearing/Hinge attached)

mass
1.4 kg

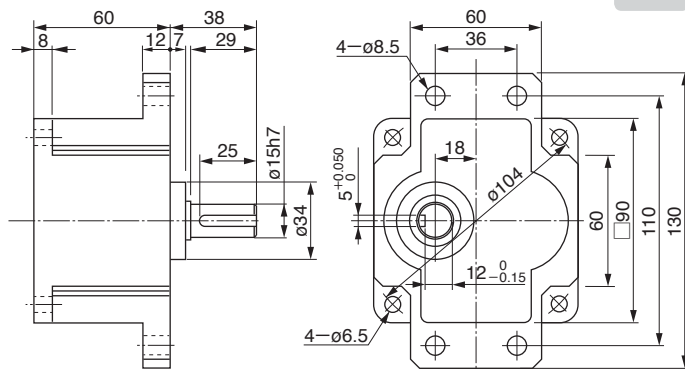

Brushless amplifier (dimensions)

Unit mm

mass
0.37 kg

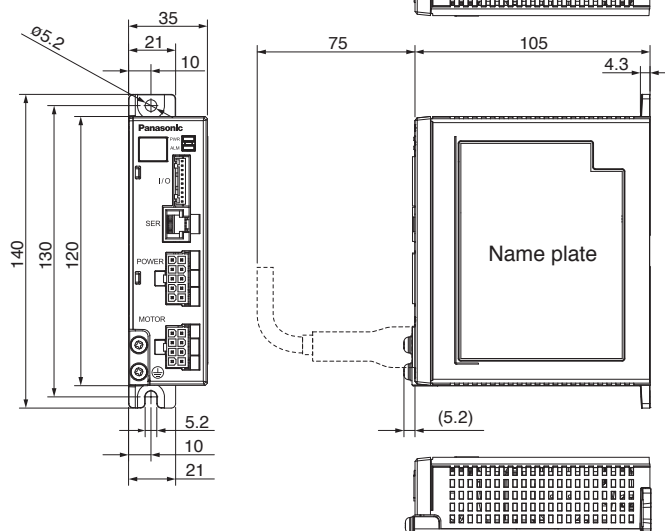

<Key and keyway [attachment]>

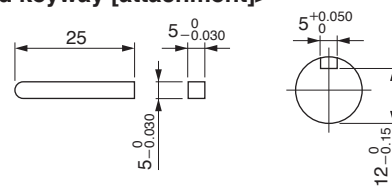

<Cautions> Dimensions are subject to change without notice. Contact us or a dealer for the latest information.

MINAS-BL GV series

■ Specification (For Common specification, see p. 11, 12)

Size	Model No. / Amplifier and Motor		Rated output (W)	Input power supply for Amplifier			Rated torque (N·m)	Starting torque (N·m)	Rated speed (r/min)	Maximum rotation speed (r/min)	
	Brushless Amplifier	Motor		Voltage AC (V)	Allowed range (%)	Frequency (Hz)					Rated input current (A)
90 mm sq.	MBEG1E1BCV	MBMU1E1A○	130	Single phase 100 to 120	±10	50/60	2.8	0.41	0.62	3000	4000
	MBEG1E5BCV	MBMU1E2A○		Single phase 200 to 240 /3-phase			Single phase 1.5 3-phase 0.7				

* Suffix of "○" in the motor model No. represents shape of shaft.

* Starting torque: Representative value

■ Permissible torque at output shaft of gear head (N·m)

Applicable Gear head	Reduction ratio	Reduction ratio																								
		3	3.6	5	6	7.5	9	10	12.5	15	18	20	25	30	36	50	60	75	90	100	120	150	180	200		
MZ9G□B MY9G□B	motor rotation speed (r/min)	3000 or less	1.01	1.21	1.69	2.02	2.54	3.04	3.42	3.82	4.59	5.58	6.17	7.91	9.34	10.5	14.7	17.5	19.6							
		3000 to 4000	0.59	0.71	0.99	1.18	1.49	1.78	2.00	2.24	2.69	3.27	3.61	4.63	5.47	6.15	8.60	10.2	12.9	15.4	17.2	19.6				
	200 V	0.76	0.91	1.27	1.52	1.91	2.28	2.57	2.87	3.44	4.19	4.63	5.93	7.01	7.88	11.0	13.1	16.5	19.6							
	Rotational direction	Same as motor rotational direction									Reverse to motor rotational direction						Same as motor rotational direction									

■ Permissible load inertia moment (×10⁻⁴ kg·m²)

Reduction ratio	3	3.6	5	6	7.5	9	10	12.5	15	18	20	25	30	36	50	60	75	90	100	120	150	180	200
Applicable Gear head																							
MZ9G□B / MY9G□B	5.93	8.47	16.4	23.6	37.3	53.4	67.6	98.3	142	211	257	423	589	847	1684								

■ Permissible shaft load

Motor and Gear head

Overhung load (W)

Thrust load (F)

Attachment side

		Overhung load (W)	Thrust load (F)
Motor shaft (Round shaft)	Output	150 N	20 N
	130 W		
Applicable Gear head	MZ9G□B MY9G□B	588 N	147 N

■ Wiring diagram

• In Case of 3-Phase 200 V

*When you use single phase, connect the main power between L1 and L2 terminals.

Power supply input

MCCB (Molded case circuit breaker)

Noise filter

External regenerative resistor

Connector for control signals (I/O)

External speed setting Variable resistor 5 kΩ B characteristic 1/4 W

Change of Direction

Run/Stop command

Please refer to P.69 for the wiring of the motor extension cable.

Be sure to ground the grounding terminal.

In wiring to power supply (outside of equipment) from MCCB, use an electric wire of 1.6 mm diameter (2.0 mm²) or more both for main circuit and grounding. Apply grounding class D (100 Ω or below) for grounding. Do not tighten the ground wires together, but connect them individually.

■ Speed-torque characteristic (Dotted line shows a characteristic curve when supply voltage drops by 10 %.)

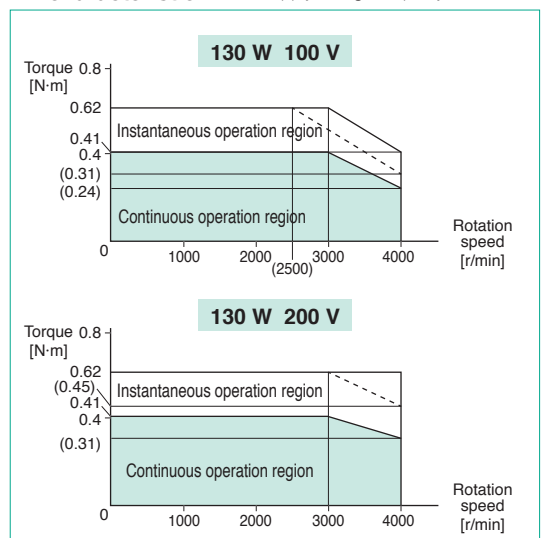

* Before using, be sure to read "Instruction manual" to check precautions and correct procedure.

Motor (dimensions)

Unit mm

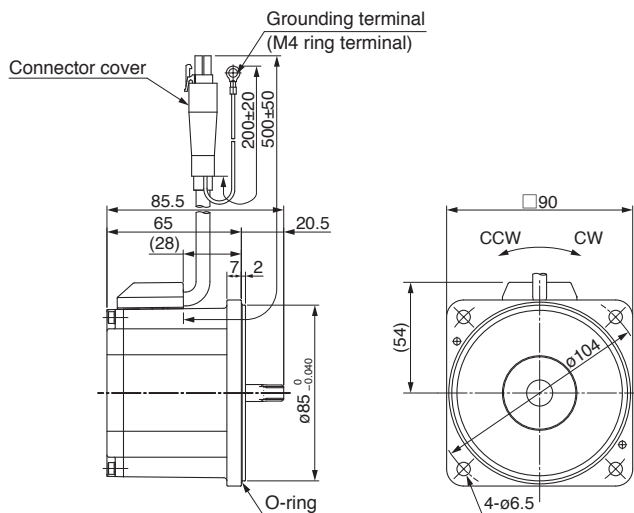

<Round shaft type>

mass
1.2 kg

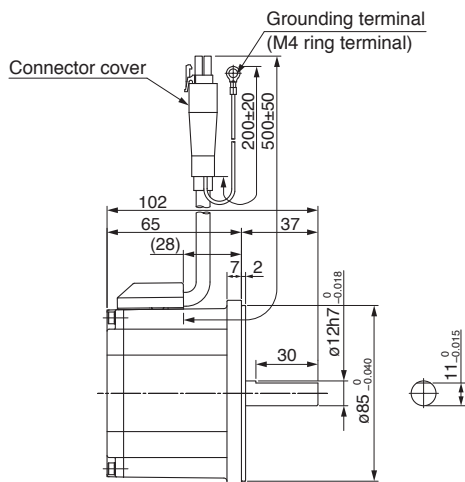

Gear head (dimensions)

Unit mm

MZ9G□B (Ball bearing/Hinge not attached)

mass
1.4 kg

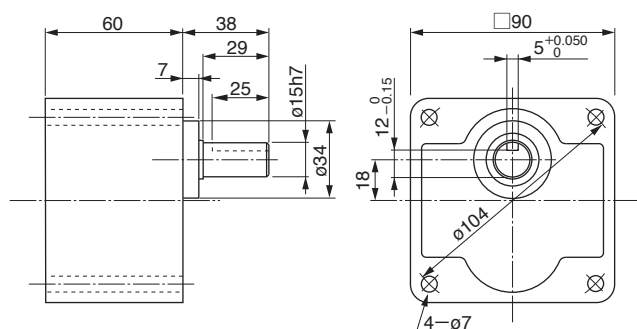

MY9G□B (Ball bearing/Hinge attached)

mass
1.4 kg

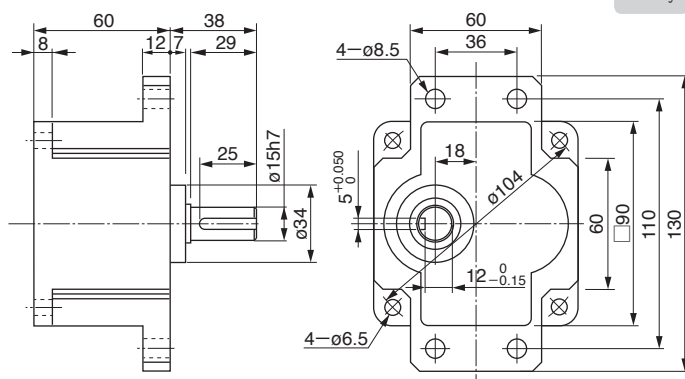

Brushless amplifier (dimensions)

Unit mm

mass
0.37 kg

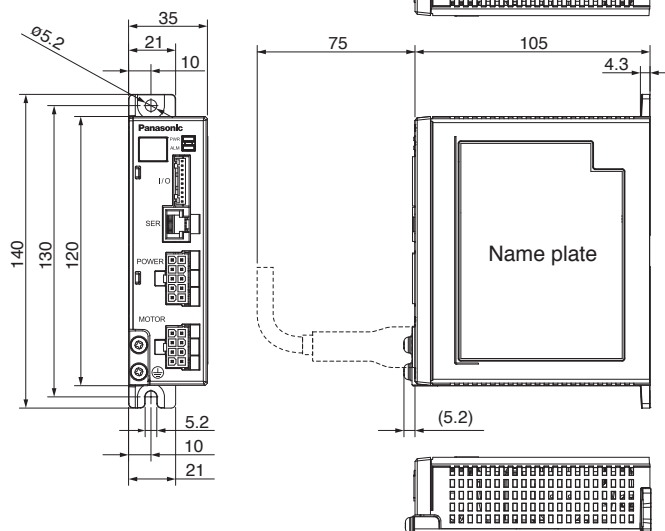

<Key and keyway [attachment]>

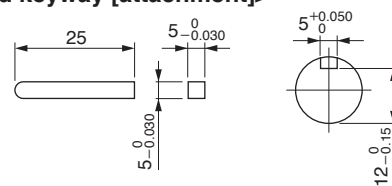

<Cautions> Dimensions are subject to change without notice. Contact us or a dealer for the latest information.

Nominal reduction ratio and actual reduction ratio

Note that there is a difference between the nominal reduction ratio and actual reduction ratio of each gear head. Refer to the table on the right.

■ Gear head

Nominal reduction ratio	Actual reduction ratio	
	MX8G□	MZ9G□, MY9G□
1/3	1/3.01	1/3.02
1/3.6	1/3.60	1/3.61
1/5	1/4.98	1/5.03
1/6	1/5.96	1/6.02
1/7.5	1/7.48	1/7.58
1/9	1/9.00	1/9.06
1/10	1/9.99	1/10.2
1/12.5	1/12.5	1/12.3
1/15	1/14.9	1/14.8
1/18	1/18.1	1/18.0
1/20	1/20.1	1/19.9
1/25	1/25.1	1/25.5
1/30	1/30.3	1/30.1
1/36	1/36.4	1/36.1
1/50	1/49.8	1/50.9
1/60	1/61.2	1/60.5
1/75	1/76.2	1/76.0
1/90	1/90.5	1/89.8
1/100	1/98.0	1/98.6
1/120	1/122.5	1/121.2
1/150	1/148.9	1/150.4
1/180	1/183.5	1/182.1
1/200	—	1/202.1

* 1/200: only 90 mm sq. size

Gear head efficiency

Model No.	Reduction ratio																						
	3	3.6	5	6	7.5	9	10	12.5	15	18	20	25	30	36	50	60	75	90	100	120	150	180	200
MX8G□B						81 %												75 %					—
MZ9G□B MY9G□B			81 %							75 %								70 %					

Gear head efficiency and ambient temperature

Calculate the actual gear head efficiency by multiplying the above-shown gear head efficiency at room temperature by the torque reduction ratio shown right.

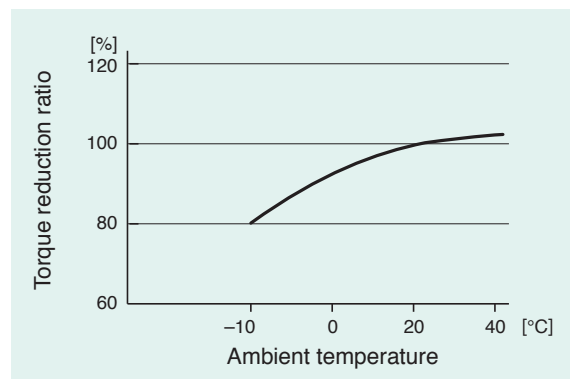

<Important>

The gear heads MB8G□BV and MB9G□BV are designed for use with GP series, and MX8G□B, MZ9G□B and MY9G□B are designed for use with GV series, respectively, and they are not compatible with gear heads of different series.

Gear head GV series

Model list of gear head

Gear head

■ Ball bearing

Size	Reduction ratio	Model No.	Hinge
80 mm sq. (50 W)	1/3, 1/3.6, 1/5, 1/6, 1/7.5, 1/9, 1/10, 1/12.5, 1/15, 1/18	MX8G3B to MX8G18B	
	1/20, 1/25, 1/30, 1/36	MX8G20B to MX8G36B	
	1/50, 1/60, 1/75, 1/90, 1/100, 1/120, 1/150, 1/180	MX8G50B to MX8G180B	
90 mm sq. (90 W•130 W) (Common use)	1/3, 1/3.6, 1/5, 1/6, 1/7.5, 1/9	MZ9G3B to MZ9G9B	
	1/10, 1/12.5, 1/15, 1/18	MZ9G10B to MZ9G18B	
	1/20, 1/25, 1/30, 1/36, 1/50, 1/60	MZ9G20B to MZ9G60B	
	1/75, 1/90, 1/100, 1/120, 1/150, 1/180, 1/200	MZ9G75B to MZ9G200B	
	1/3, 1/3.6, 1/5, 1/6, 1/7.5, 1/9	MY9G3B to MY9G9B	○
	1/10, 1/12.5, 1/15, 1/18	MY9G10B to MY9G18B	○
	1/20, 1/25, 1/30, 1/36, 1/50, 1/60	MY9G20B to MY9G60B	○
	1/75, 1/90, 1/100, 1/120, 1/150, 1/180, 1/200	MY9G75B to MY9G200B	○

* For the specifications for each item, refer to the page of the motor to which it can be applied.

Gear head accessory

■ Ball bearing

Size	Reduction ratio	Model No.	Accessory			
			Screw (mm)	Flat washer	Hexagon nut	Key
80 mm sq.	1/3 to 1/180	MX8G3B to MX8G180B	M5 × 55 pan head screw : 4	for M5: 4	M5 : 4	4×4×25 one-end round : 1
90 mm sq.	1/3 to 1/200	MZ9G3B to MZ9G200B	M6 × 85 hexagon socket head bolt : 4	for M6: 4	M6 : 4	5×5×25 one-end round : 1
	1/3 to 1/200	MY9G3B to MY9G200B	M6 × 25 hexagon socket head bolt : 4	for M6: 4	M6 : 4	5×5×25 one-end round : 1

Options

Options

GV series

KV series

GP series

Options

Information



Contents
Options – Details67
List of peripheral equipments74

Option

Noise filter/ Surge absorber/ MCCB

Part name	Optional parts number (option)	Manufacturer's parts number	Qty.	Manufacturer
Noise filter (single phase 100 V, 200 V)	DV0P4170	SUP-EK5-ER-6	1	OKAYA ELECTRIC IND. CO., LTD.
Noise filter (3-phase)	DV0PM20042	3SUP-HU10-ER-6	1	
Surge absorber (single phase 100 V, 200 V)	DV0P4190	R•A•V-781BWZ-4	1	
Surge absorber (3-phase)	DV0P1450	R•A•V-781BXZ-4	1	
Noise filter for control signals	DV0P1460	ZCAT3035-1330	4	TDK Corporation

Noise filter GV KV GP

• DV0P4170

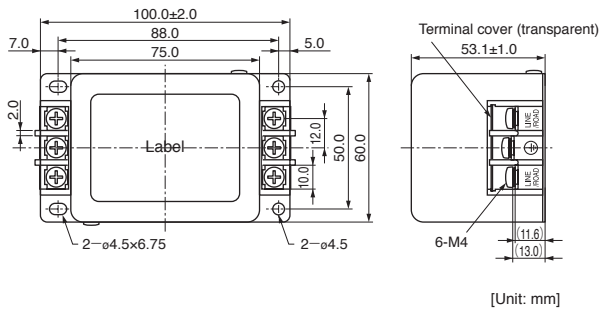

• DV0PM20042

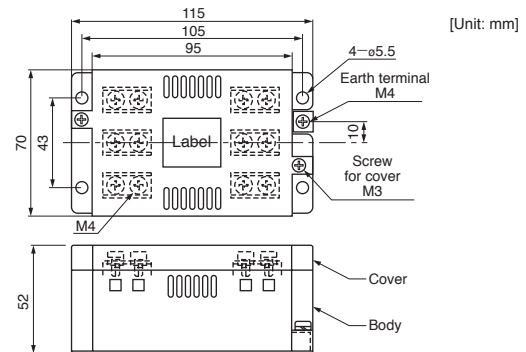

Surge absorber GV KV GP

• DV0P4190

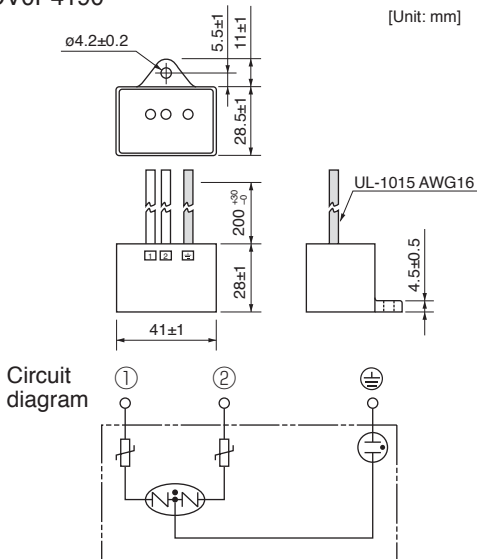

• DV0P1450

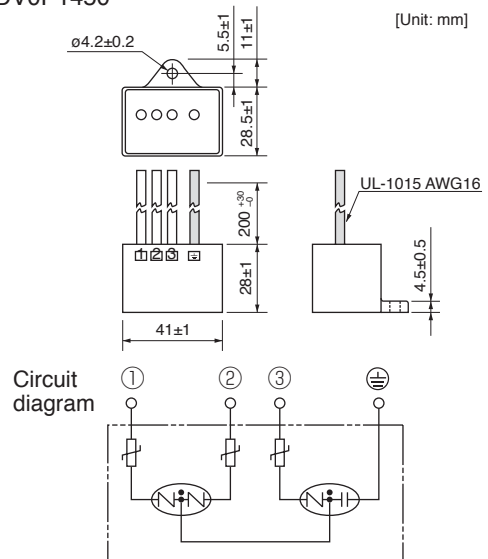

Noise filter for control signals GV KV GP

• DV0P1460

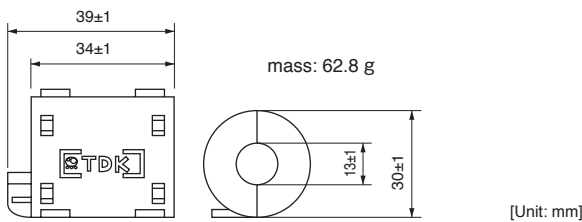

Recommended circuit breaker (MCCB)

Made by Sensata Technologies Japan Limited: Type IELH-1-11-63-5A-M (single phase) Type IELH-1-111-63-5A-M (3-phase)
(Rated current 5A, cutoff characteristics DELAY63)

- Recommended cutoff characteristics: DELAY61-63

Settings

Console A GV KV

Optional part number

DV0P3500

- Speed adjusting knob
- RUN/STOP switch
- Rotation direction selector switch

Console A connector pin No.

6	1
10	5

Console A connector terminal symbol

Terminal No.	1	2	3	4	5	6	7	8	9	10
Terminal name	I1	I2	GND	FIN	+5V	—	—	—	—	—

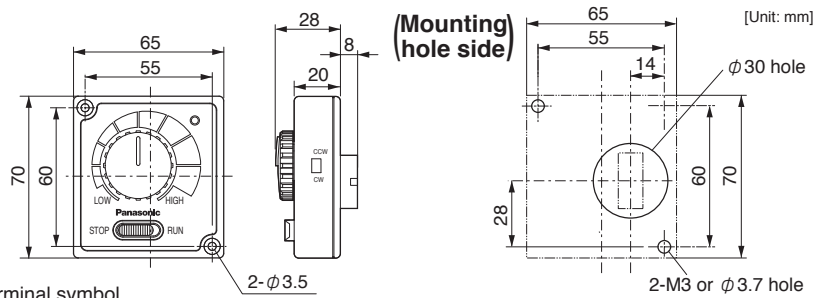

Digital key pad GV KV GP

Optional part number

DV0P3510

- Digital display (Speed, torque, voltage)
- Parameter settings change
- Parameter storage (read/write)

Digital key pad connector pin No.

6	1
10	5

Digital key pad connector terminal symbol

Terminal No.	1	2	3	4	5	6	7	8	9	10
Terminal name	—	—	GND	—	+5V	—	SCK	SIN	SOT	—

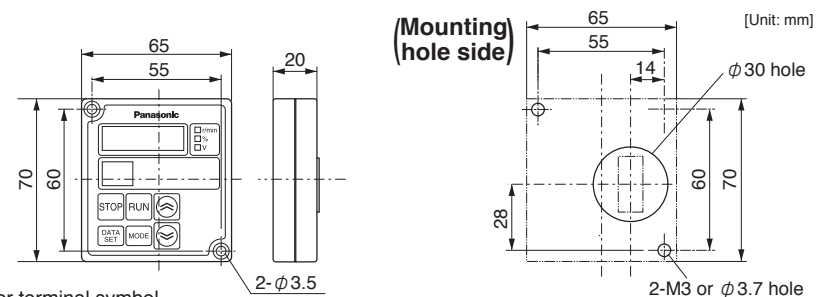

Cable

Console A connection cable GV KV

Optional parts number	Length (L)
DV0PM2006910	1 m
DV0PM2006930	3 m
DV0PM2006950	5 m

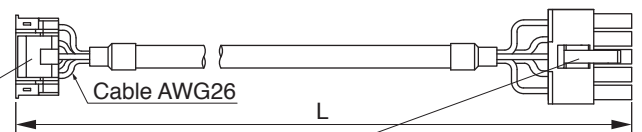

Amp. I/O side connector (J.S.T Mfg. Co., Ltd.)
Connector : PAP-10V-S
Connector pin : SPHD-002T-P0.5

Console A side connector (Molex Inc.)
Connector : 39-01-2105 (5557-10R-210)
Connector pin : 39-00-0046 (5556T2)
or
39-00-0047 (5556T2L)

Amp. I/O side connector pin No.	1	2	3	4	5	6	7	8	9	10
Lead color of a cable	Brown	Red				Orange	Yellow	Green		
Console A side connector pin No.	1	2	—	—	—	3	4	5	—	—

Digital key pad connection cable GV KV GP

Optional parts number	Length (L)
DV0P38310	1 m
DV0P38330	3 m
DV0P38350	5 m

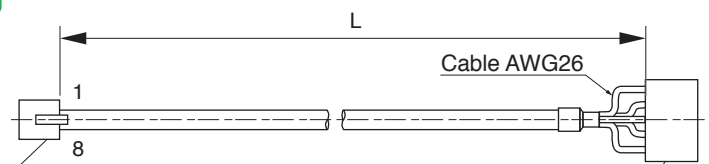

Amp. side connector (SER)/modular plug RJ45

Digital key pad side connector (Molex Inc.)
Connector : 39-01-2105 (5557-10R-210)
Connector pin : 39-00-0046 (5556T2)
or
39-00-0047 (5556T2L)

Amp. side connector pin No. (SER)	1	2	3	4	5	6	7	8
Terminal name	—	+5V	SOT	SIN	—	—	GND	SCK
Digital key pad side connector pin No.	—	5	9	8	—	—	3	7

Option

Motor extension cable

GV GP

Optional parts number	Length (L)
DV0PQ1000110	1 m
DV0PQ1000130	3 m
DV0PQ1000150	5 m
DV0PQ10001A1	10 m

Accessories

- Insulating cap (for grounding wire insulation) 1
- M4 × 6 pan head screw with spring washer 1
- M4 hex. nut 1

Insulating cap (for grounding wire insulation)

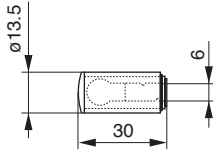

[Unit: mm]

- When using motor extension cable, be sure to connect its grounding wire to the grounding wire of the motor, and connect the other end of grounding wire of the extension cable to the earth terminal of the brushless amplifier.
- For connecting grounding wire of motor and motor extension cable, use M4 screw and insulating cap supplied as accessories.

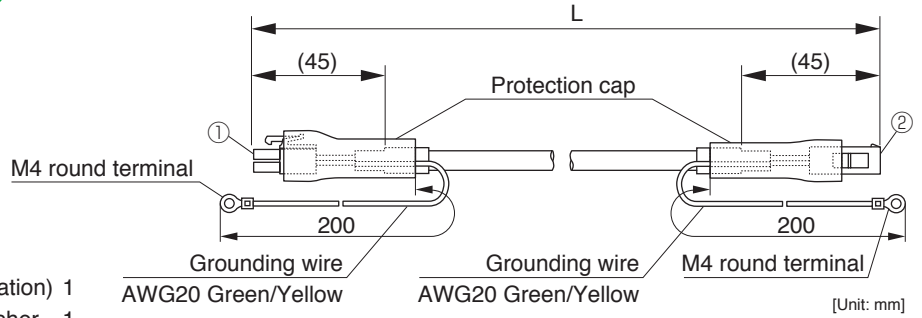

[Unit: mm]

- ① Brushless amplifier side connector (Molex Inc.)
 Connector : 39-01-2085 (5557-08R-210)
 Connector pin : 39-00-0039 (5556TL) [for AWG 20]
 39-00-0047 (5556T2L) [for AWG 26]
- ② Motor side connector (Molex Inc.)
 Connector : 39-01-2086 (5559-08P-210)
 Connector pin : 39-00-0041 (5558TL) [for AWG 20]
 39-00-0049 (5558T2L) [for AWG 26]

<Connector wiring>

• Brushless amplifier side

Pin No.	Signal	Wire color	Wire size
1	U	Red	AWG20
2	V	White	AWG20
3	W	Black	AWG20
4	Vcc	White	AWG26
5	CS1	Red	AWG26
6	CS2	Blue	AWG26
7	CS3	Yellow	AWG26
8	0V	Black	AWG26
M4 round terminal	E	Green/Yellow	AWG20

• Motor side

Pin No.
1
2
3
4
5
6
7
8
M4 round terminal

Motor extension cable

KV

Optional parts number	Length (L)
DV0PQ1000310	1 m
DV0PQ1000330	3 m
DV0PQ1000350	5 m
DV0PQ10003A1	10 m

<Wiring of motor side connector>

• Motor connector

Pin No.	Signal	Wire color
1	U	Red
2	V	White
3	W	Black
4	E	Green/Yellow

• Sensor connector

Pin No.	Signal	Wire color
1	CS1	Red
2	CS2	Blue
3	CS3	Yellow
4	Vcc	White
5	0V	Black
6	NC	—

Do not connect anything on (NC).

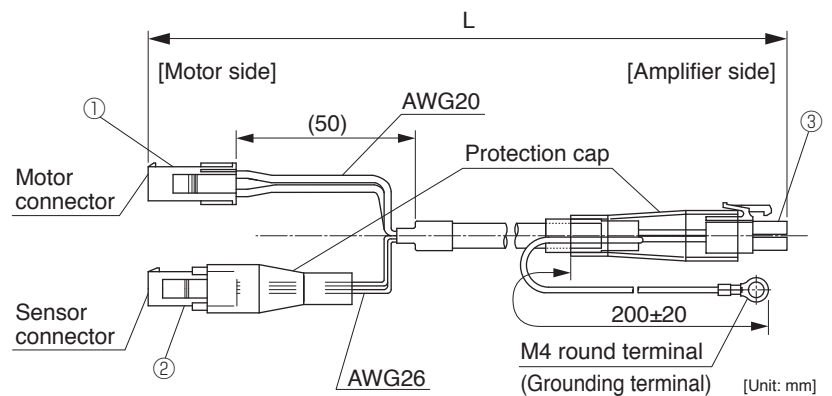

[Unit: mm]

- ① Motor side motor connector (Tyco Electronics.)
 Connector : 172159-1
 Connector pin : 170366-1 [for AWG 20]
- ② Motor side sensor connector (Molex Inc.)
 Connector : 39-01-2066 (5559-06P-210)
 Connector pin : 39-00-0049 (5558T2L) [for AWG 26]
- ③ Brushless amplifier side connector (Molex Inc.)
 Connector : 39-01-2085 (5557-08R-210)
 Connector pin : 39-00-0039 (5556TL) [for AWG 20]
 39-00-0047 (5556T2L) [for AWG 26]

<Connector wiring of amplifier side>

Pin No.	Signal	Wire color	Wire size
1	U	Red	AWG20
2	V	White	AWG20
3	W	Black	AWG20
4	Vcc	White	AWG26
5	CS1	Red	AWG26
6	CS2	Blue	AWG26
7	CS3	Yellow	AWG26
8	0V	Black	AWG26
M4 round terminal	E	Green/Yellow	AWG20

PC connection cable (10-pin D-sub connector pin 1.5 m) GV KV GP

Optional parts number	Length (L)
DV0P4140	1.5 m

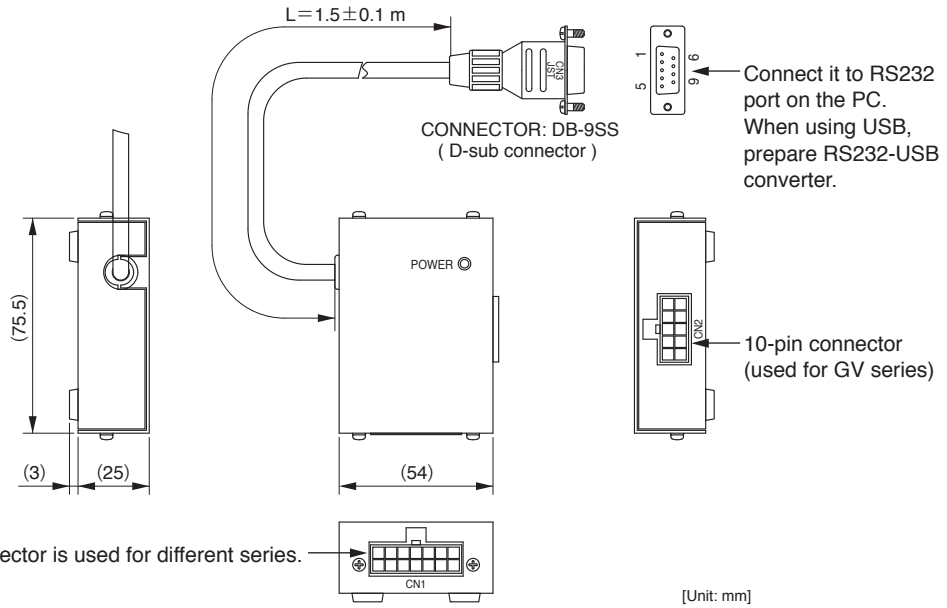

Communication software GV KV GP

Model No.	
PANATERM for BL	Can be downloaded from our web site, free of charge. http://industrial.panasonic.com/ww/i_e/25000/motor_fa_e/motor_fa_e.html

Connector Kit/ Cable/ External speed setter

Power supply connector kit GV KV (50 W, 100 W) GP

Optional part number	Name	Manufacturer's parts No.	Qty.	Manufacturer	Note
DV0P2870	Connector	39-01-2105 (5557-10R-210)	1	Molex Inc	Fits to power supply connector (POWER)
	Connector pin	39-00-0060 (5556PBTL)	6		

• 39-01-2105 (5557-10R-210)

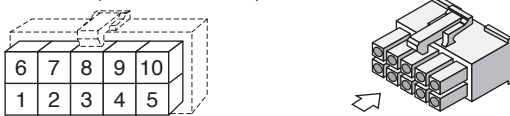

Control signal cable (Cable with an I/O connector) GV KV GP

Optional parts number	Length (L)
DV0PM20076	2 m

* Do not connect anything to the pin no.4 and pin no.7 in case of use the GP series.

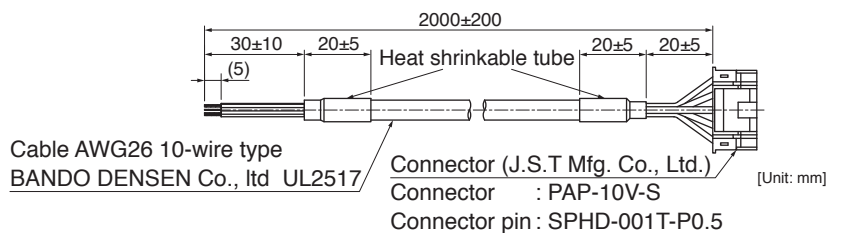

<For your reference>

For tools such as crimp tools necessary to assemble the cable, access the connector manufacturer's web site or consult the manufacturer: refer to p. 74 "List of peripheral equipment manufacturers".

Option

I/O connector kit

GV **KV** **GP**

Optional part number	Name	Manufacturer's parts No.	Qty.	Manufacturer	Note
DV0PM20070	Connector	PAP-10V-S	1	J.S.T Mfg.Co.,Ltd.	Fits to I/O connector
	Connector pin	SPHD-002T-P0.5	10		

• PAP-10V-S

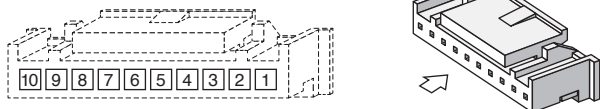

External speed setter

GV **KV**

Optional part number

DV0PM20078



5 kΩ B characteristic 1/4 W

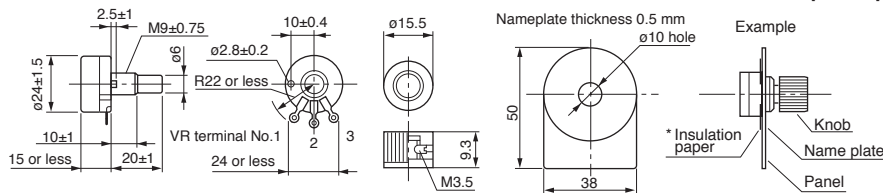

* Insert the insulation paper to positively isolate the terminals and chassis.

Panel connector kit (Fits to Console A)

GV **KV**

Optional part number	Name	Manufacturer's parts No.	Qty.	Manufacturer	Note
DV0P3610	Connector	39-01-2105 (5557-10R-210)	1	Molex Inc	Fits to Console A
	Connector pin	39-00-0047 (5556T2L)	10		

• 39-01-2105 (5557-10R-210)



External regenerative resistor

GV **KV** **GP**

Optional parts number	Specifications	Manufacturer
DV0P2890	100 V, 50 Ω 10 W	Iwaki Musen Kenkyusho Co., Ltd
DV0PM20068	200 V, 200 Ω 10 W	

• DV0P2890, DV0PM20068

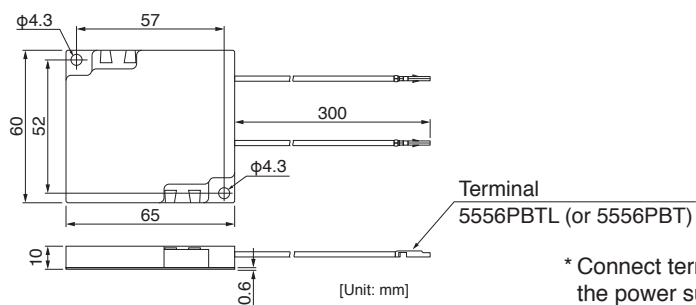

* Connect terminals to pins No. 3 and No. 5 of the power supply connector, respectively.

<For your reference>

For tools such as crimp tools necessary to assemble the cable, access the connector manufacturer's web site or consult the manufacturer: refer to p. 74 "List of peripheral equipment manufacturers".

DIN rail mounting unit **GV** **KV** (50 W, 100 W) **GP**

Optional part number

DV0P3811

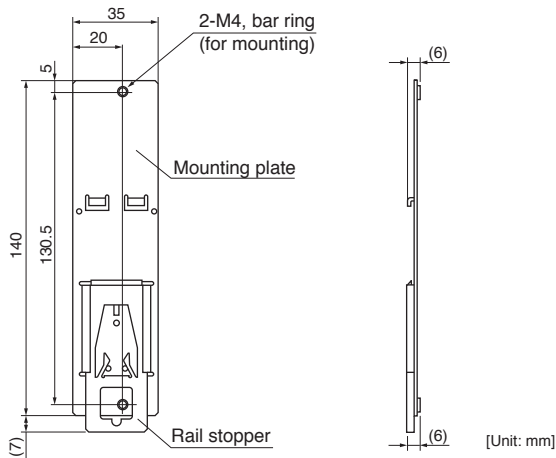

• How to Install

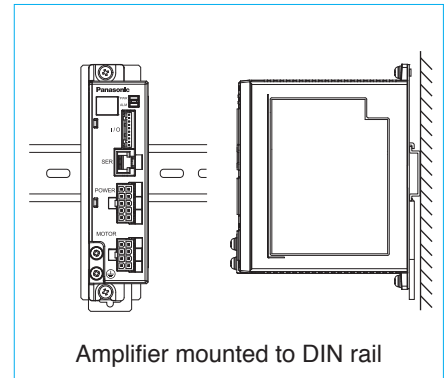
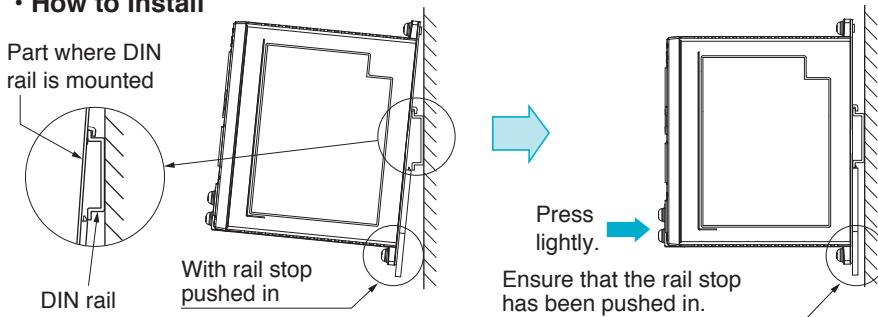

Hook the upper side of DIN rail mounting part on the DIN rail.

Press lightly the lower part of the main body of amplifier.

• Removing from DIN Rail

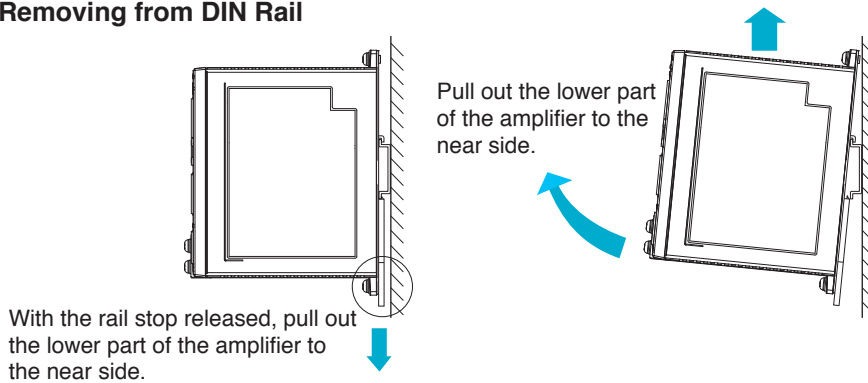

By lifting the amplifier, you can remove it from the DIN rail.

Option

Reactor **GV** **KV** **GP**

Fig.1

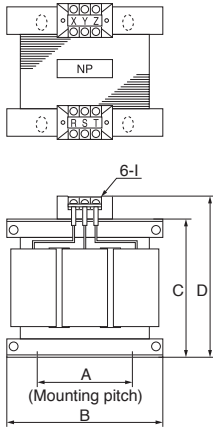

•Wiring of the reactor
<3-Phase 200 V>

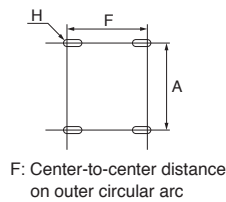
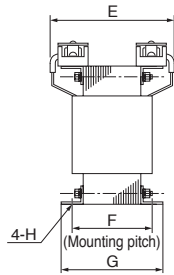
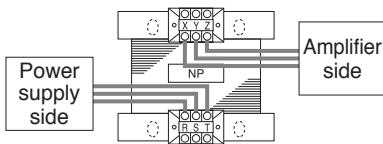
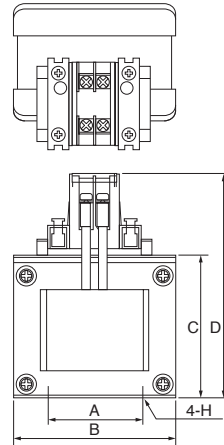
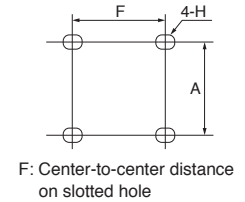
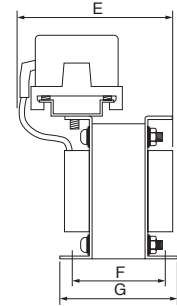
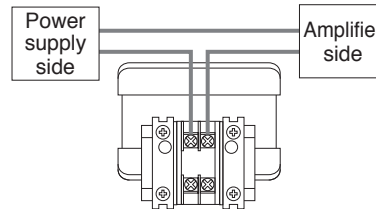

Fig.2



•Wiring of the reactor
<Single phase 100 V, 200 V>



[Unit: mm]

	Optional parts number	A	B	C	D	E(Max)	F	G	H	I	Inductance (mH)	Rated current (A)
Fig.1	DV0P220	65±1	125±1	(93)	136Max	155	70+3/-0	85±2	4-7 \times 12	M4	6.81	3
Fig.2	DV0P227	55±0.7	80±1	66.5±1	110Max	90	41±2	55±2	4-5 \times 10	M4	4.02	5
	DV0P228	55±0.7	80±1	66.5±1	110Max	95	46±2	60±2	4-5 \times 10	M4	2	8

* For applicability of reactor, refer to the corresponding table on p. 95.

Harmonic restraint

Harmonic restraint measures are not common to all countries. Therefore, prepare the measures that meet the requirements of the destination country.

With products for Japan, on September, 1994, "Guidelines for harmonic restraint on heavy consumers who receive power through high voltage system or extra high voltage system" and "Guidelines for harmonic restraint on household electrical appliances and general-purpose articles" established by the Agency for Natural Resources and Energy of the Ministry of Economy, Trade and Industry (the ex-Ministry of International Trade and Industry). According to those guidelines, the Japan Electrical Manufacturers' Association (JEMA) have prepared technical documents (procedure to execute harmonic restraint:

JEM-TR 198, JEM-TR 199 and JEM-TR 201) and have been requesting the users to understand the restraint and to cooperate with us. On January, 2004, it has been decided to exclude the general-purpose inverter and servo driver from the "Guidelines for harmonic restraint on household electrical appliances and general-purpose articles". After that, the "Guidelines for harmonic restraint on household electrical appliances and general-purpose articles" was abolished on September 6, 2004.

We are pleased to inform you that the procedure to execute the harmonic restraint on general-purpose inverter and servo driver was modified as follows.

1. All types of the general-purpose inverters and servo drivers used by specific users are under the control of the "Guidelines for harmonic restraint on heavy consumers who receive power through high voltage system or extra high voltage system". The users who are required to apply the guidelines must calculate the equivalent capacity and harmonic current according to the guidelines and must take appropriate countermeasures if the harmonic current exceeds a limit value specified in a contract demand. (Refer to JEM-TR 210 and JEM-TR 225.)
2. The "Guidelines for harmonic restraint on household electrical appliances and general-purpose articles" was abolished on September 6, 2004. However, based on conventional guidelines, JEMA applies the technical documents JEM-TR 226 and JEM-TR 227 to any users who do not fit into the "Guidelines for harmonic restraint on heavy consumers who receive power through high voltage system or extra high voltage system" from a perspective on enlightenment on general harmonic restraint. The purpose of these guidelines is the execution of harmonic restraint at every device by a user as usual to the utmost extent.

<Remarks>

When using a reactor, be sure to install one reactor to one brushless amplifier.

List of peripheral equipments

Manufacturer	Tel No. / Home page	Peripheral components
TDK Corporation	+81-3-5201-7229 http://www.tdk.co.jp/	Noise filter for signal lines
Okaya Electric Industries Co. Ltd.	+81-3-4544-7040 http://www.okayatec.co.jp/	Surge absorber Noise filter
Sensata Technologies Japan Limited	+81-49-283-7575 www.sensata.com/japan	Circuit breaker (MCCB)
Japan Molex Inc.	+81-462-65-2313 http://www.molex.co.jp	Connector
J.S.T. Mfg. Co., Ltd.	+81-45-543-1271 http://www.jst-mfg.com/index_i.html	
Iwaki Musen Kenkyusho Co., Ltd.	+81-44-833-4311 http://www.iwakimusen.co.jp/	Regenerative resistor

* This list is for reference only and subject to change without notice.

Power cable (single phase 100 V, 200 V) with connector **GV** **KV** (50 W, 100 W) **GP**

When the following part number is specified in the order, the power cable is delivered with the product.

		50 W	90 W	100 W	130 W
GV series	100 V	MBEG5A1BCVC	MBEG9A1BCVC	—	MBEG1E1BCVC
	200 V	MBEG5A5BCVC	MBEG9A5BCVC		MBEG1E5BCVC
KV series	100 V	MBEK5A1BCVC	—	MBEK011BCVC	—
	200 V	MBEK5A5BCVC		MBEK015BCVC	
GP series	100 V	MBEG5A1BCPC	MBEG9A1BCPC	—	MBEG1E1BCPC
	200 V	MBEG5A5BCPC	MBEG9A5BCPC		MBEG1E5BCPC

- When supplying 3-phase power source to a 200 V brushless amplifier, use the supplied power cable and connect 2 conductors to L1 and L2.
- When supplying 3-phase power, use a power connection kit and connect three conductors to L1, L2 and L3.
- For location of L1, L2 and L3, refer to the wiring diagram on pages 17, 19 and 21 (GV series), pages 55, 57 and 59 (GP series).

■ Cable specification

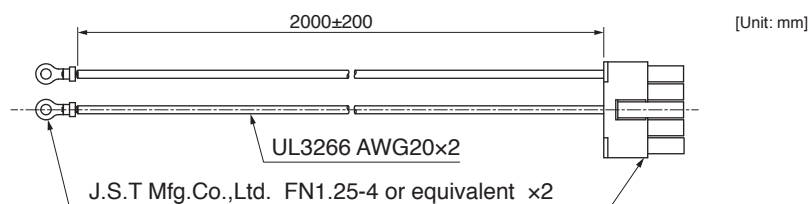

Connector for power supply connection (Molex Inc.)

Connector : 39-01-2105 (5557-10R-210)

Connector pin : 39-00-0038 (5556T) or 39-00-0039 (5556T2)

- Grounding wire

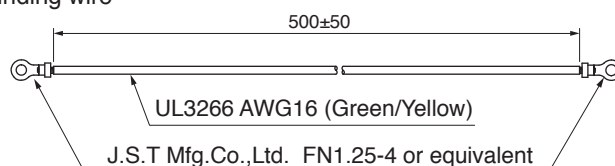

MEMO

A series of horizontal dashed lines for writing.

Information

Information

GV series

KV series

GP series

Options

Information

Contents

- Guide to the international system of units (SI)77
- Selecting motor capacity79
- Conformance to international safety standards93
- Table of part numbers and options95
- Index97
- Sales office101

Guide to the international system of units (SI)

Organization of the system of units

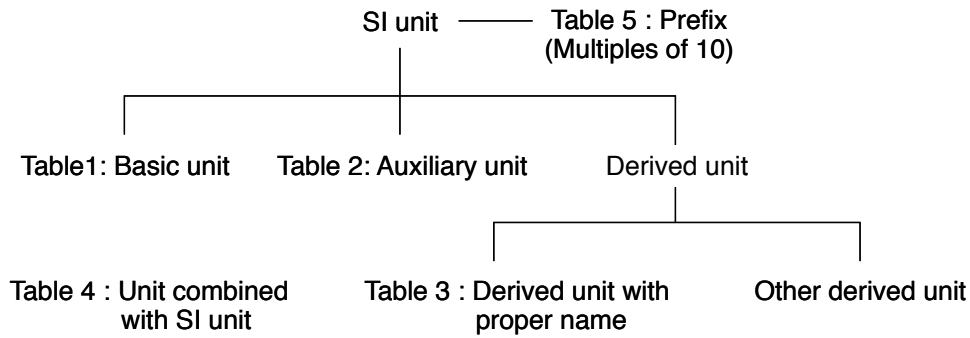

Table 1: Basic unit

Quantity	Name of unit	Symbol of unit
Length	meter	m
Weight	kilogram	kg
Time	second	s
Current	ampere	A
Thermodynamic temperature	kelvin	K
Amount of substance	mol	mol
Luminous intensity	candela	cd

Table 2: Auxiliary unit

Quantity	Name of unit	Symbol of unit
Plane angle	radian	rad
Solid angle	steradian	sr

Table 3: Major derived unit with proper name

Quantity	Name	Symbol of unit	Derivation from basic unit, auxiliary unit or other derived unit
Frequency	hertz	Hz	1 Hz = 1 s ⁻¹
Force	newton	N	1 N = 1 kg·m/s ²
Pressure, Stress	pascal	Pa	1 Pa = 1 N/m ²
Energy, Work, Amount of heat	joule	J	1 J = 1 N·m
Amount of work, Work efficiency, Power, Electric power	watt	W	1 W = 1 J/s
Electric charge, Amount of electricity	coulomb	C	1 C = 1 A·s
Electric potential, Potential difference, Voltage, Electromotive force	volt	V	1 V = 1 J/C
Electrostatic capacity, Capacitance	farad	F	1 F = 1 C/V
Electric resistance	ohm	Ω	1 Ω = 1 V/A
Electric conductance	siemens	S	1 S = 1 Ω ⁻¹
Magnetic flux	weber	Wb	1 Wb = 1 V·s
Magnetic flux density, Magnetic induction	tesla	T	1 T = 1 Wb/m ²
Inductance	henry	H	1 H = 1 Wb/A
Degree centigrade (Celsius)	degree centigrade (Celsius)/ degree	°C	t °C = (t+273.15) K
Luminous flux	lumen	lm	1 lm = 1 cd·sr
Illuminance	lux	lx	1 lx = 1 lm/m ²

Table 4: Unit combined with SI unit

Quantity	Name	Symbol of unit
Time	minute	min
	hour	h
	day	d
Plane angle	degree	°
	minute	'
	second	"
Volume	liter	l, L
Weight	ton	t

Table 5: Prefix

Multiples powered to unit	Prefix	
	Name	Symbol
10 ¹⁸	exa	E
10 ¹⁵	peta	P
10 ¹²	tera	T
10 ⁹	giga	G
10 ⁶	mega	M
10 ³	kilo	k
10 ²	hecto	h
10	deca	da
10 ⁻¹	deci	d
10 ⁻²	centi	c
10 ⁻³	milli	m
10 ⁻⁶	micro	μ
10 ⁻⁹	nano	n
10 ⁻¹²	pico	p
10 ⁻¹⁵	femto	f
10 ⁻¹⁸	atto	a

Major compatible unit

Quantity	Symbol of conventional unit	Symbol of SI unit and compatible unit	Conversion value
Length	μ (micron)	μm	$1 \mu = 1 \mu\text{m}$ (micrometer)
Acceleration	Gal	m/s^2	$1 \text{ Gal} = 10^{-2} \text{ m/s}^2$
	G	m/s^2	$1 \text{ G} = 9.80665 \text{ m/s}^2$
Frequency	c/s, c	Hz	$1 \text{ c/s} = \text{Hz}$
Revolving speed, Number of revolutions	rpm	s^{-1} or min^{-1} , r/min	$1 \text{ rpm} = 1 \text{ min}^{-1}$
Weight	kgf	–	} Same value
Mass	–	kg	
Weight flow rate	kgf/s	–	} Same value
Mass flow rate	–	kg/s	
Specific weight	kgf/m ³	–	} Same value
Density	–	kg/m ³	
Specific volume	m ³ /kgf	m ³ /kg	Same value
Load	kgf	N	$1 \text{ kgf} = 9.80665 \text{ N}$
Force	kgf	N	$1 \text{ kgf} = 9.80665 \text{ N}$
	dyn	N	$1 \text{ dyn} = 10^{-5} \text{ N}$
Moment of force	kgf·m	N·m	$1 \text{ kgf·m} = 9.806 \text{ N·m}$
Pressure	kgf/cm ²	Pa, bar ⁽¹⁾ or kgf/cm ²	$1 \text{ kgf/cm}^2 = 9.80665 \times 10^4 \text{ Pa}$ $= 0.980665 \text{ bar}$
	at (Engineering atmospheric pressure)	Pa	$1 \text{ at} = 9.80665 \times 10^4 \text{ Pa}$
	atm (Atmospheric pressure)	Pa	$1 \text{ atm} = 1.01325 \times 10^5 \text{ Pa}$
	mH ₂ O, mAq	Pa	$1 \text{ mH}_2\text{O} = 9.80665 \times 10^3 \text{ Pa}$
	mmHg Torr	Pa or mmHg ⁽²⁾	$1 \text{ mmHg} = 133.322 \text{ Pa}$
Stress	kgf/mm ²	Pa or N/m ²	$1 \text{ kgf/mm}^2 = 9.80665 \times 10^6 \text{ Pa}$ $= 9.80665 \times 10^6 \text{ N/m}^2$
	kgf/cm ²	Pa or N/m ²	$1 \text{ kgf/cm}^2 = 9.80665 \times 10^4 \text{ Pa}$ $= 9.80665 \times 10^4 \text{ N/m}^2$
Elastic modulus	kgf/m ²	Pa or N/m ²	$1 \text{ kgf/m}^2 = 9.80665 \text{ Pa} = 9.80665 \text{ N/m}^2$ $1 \text{ kgf/cm}^2 = 9.80665 \times 10^4 \text{ N/m}^2$
Energy, Work	kgf·m	J (joule)	$1 \text{ kgf·m} = 9.80665 \text{ J}$
	erg	J	$1 \text{ erg} = 10^{-7} \text{ J}$
Work efficiency, Power	kgf·m/s	W (watt)	$1 \text{ kgf·m/s} = 9.80665 \text{ W}$
	PS	W	$1 \text{ PS} = 0.7355 \text{ kW}$
Viscosity	PP	Pa·s	$1 \text{ P} = 0.1 \text{ Pa·s}$
Kinetic viscosity	St	mm ² /s	$10^{-2} \text{ St} = 1 \text{ mm}^2/\text{s}$
Thermodynamic temperature	K	K (kelvin)	$1 \text{ K} = 1 \text{ K}$
Temperature interval	deg	K ⁽³⁾	$1 \text{ deg} = 1 \text{ K}$
Amount of heat	cal	J	$1 \text{ cal} = 4.18605 \text{ J}$
Heat capacity	cal/°C	J/K ⁽³⁾	$1 \text{ cal/}^\circ\text{C} = 4.18605 \text{ J/K}$
Specific heat, Specific heat capacity	cal/ (kgf·°C)	cal/ (kgf·K) ⁽³⁾	$1 \text{ cal/ (kgf} \cdot ^\circ\text{C)} = 4.18605 \text{ J/ (kg} \cdot \text{K)}$
Entropy	cal/K	J/K	$1 \text{ cal/K} = 4.18605 \text{ J/K}$
Specific entropy	cal/ (kgf·K)	J/(kg·K)	$1 \text{ cal/ (kgf} \cdot \text{K)} = 4.18605 \text{ J/ (kg} \cdot \text{K)}$
Internal energy (Enthalpy)	cal	J	$1 \text{ cal} = 4.18605 \text{ J}$
Specific internal energy (Specific enthalpy)	cal/kgf	J/kg	$1 \text{ cal/kgf} = 4.18605 \text{ J/kg}$
Heat flux	cal/h	W	$1 \text{ kcal/h} = 1.16279 \text{ W}$
Heat flux density	cal/ (h·m ²)	W/m ²	$1 \text{ kcal/ (h} \cdot \text{m}^2) = 1.16279 \text{ W/m}^2$
Thermal conductivity	cal/ (h·m·°C)	W/ (m·K) ⁽³⁾	$1 \text{ kcal/ (h} \cdot \text{m} \cdot ^\circ\text{C)} = 1.16279 \text{ W/ (m} \cdot \text{K)}$
Coefficient of thermal conductivity	cal/ (h·m ² ·°C)	W/ (m ² ·K) ⁽³⁾	$1 \text{ kcal/ (h} \cdot \text{m}^2 \cdot ^\circ\text{C)} = 1.16279 \text{ W/ (m}^2 \cdot \text{K)}$
Intensity of magnetic field	Oe	A/m	$1 \text{ Oe} = 10^3 / (4\pi) \text{ A/m}$
Magnetic flux	Mx	Wb (weber)	$1 \text{ Mx} = 10^{-8} \text{ Wb}$
Magnetic flux density	Gs, G	T (tesla)	$1 \text{ Gs} = 10^{-4} \text{ T}$

Note

- (1) Applicable to liquid pressure. Also applicable to atmospheric pressure of meteorological data, when “bar” is used in international standard.
(2) Applicable to scale or indication of blood pressure manometers.
(3) “°C” can be substituted for “K”.

Selecting motor capacity

Flow of motor selection

1. Definition of mechanism to be driven by motor.

Define details of individual mechanical components (ball screw length, lead and pulley diameters, etc.)

<Typical mechanism>

Ball screw mechanism

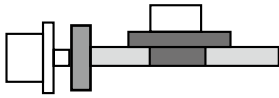

Belt mechanism

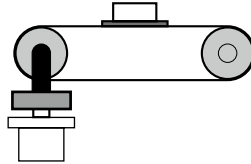

Rack & pinion, etc.

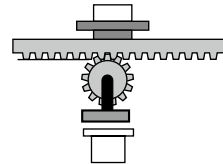

2. Definition of operating pattern.

Acceleration/deceleration time, Constant-velocity time, Stop time, Cycle time, Travel distance

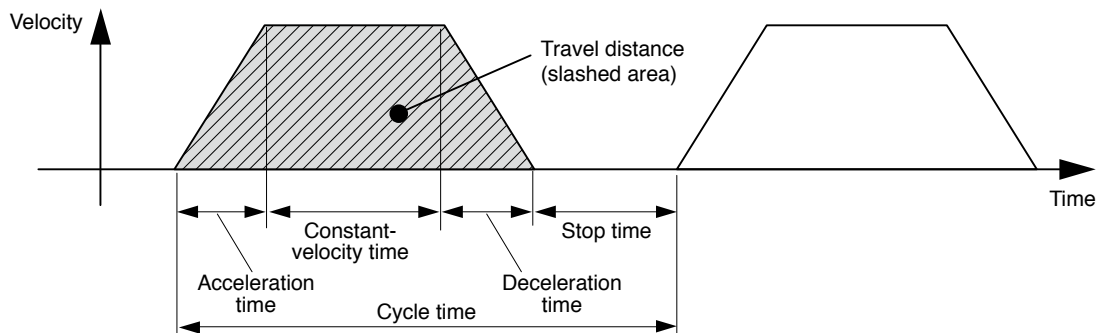

Note) Selection of motor capacity significantly varies depending on the operating pattern.

The motor capacity can be reduced if the acceleration/deceleration time and stop time are set as long as possible.

3. Calculation of load inertia and inertia ratio.

Calculate load inertia for each mechanical component. (Refer to "General inertia calculation method" described later.)

Divide the calculated load inertia by the inertia of the selected motor to check the inertia ratio.

For calculation of the inertia ratio, note that the catalog value of the motor inertia is expressed as " $\times 10^{-4}$ kg·m²".

4. Calculation of motor velocity

Calculate the motor velocity from the moving distance, acceleration / deceleration time and constant-velocity time.

5. Calculation of torque

Calculate the required motor torque from the load inertia, acceleration/deceleration time and constant-velocity time.

6. Calculation of motor

Select a motor that meets the above 3 to 5 requirements.

Description on the items related to motor selection

1. Torque

(1) Peak torque

Indicate the maximum torque that the motor requires during operation (mainly in acceleration and deceleration steps). The reference value is 80 % or less of the maximum motor torque. If the torque is a negative value, a regenerative discharge resistor may be required.

(2) Traveling torque, Stop holding torque

Indicates the torque that the motor requires for a long time. The reference value is 80 % or less of the rated motor torque. If the torque is a negative value, a regenerative discharge resistor may be required.

Traveling torque calculation formula for each mechanism

Ball screw mechanism

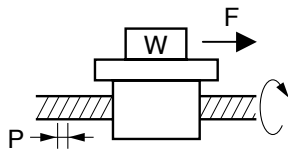

Traveling torque $T_f = \frac{P}{2\pi\eta} (\mu g W + F)$

W : Weight [kg]

η : Mechanical efficiency

P : Lead [m]

μ : Coefficient of friction

F : External force [N]

g : Acceleration of gravity 9.8 [m/s²]

Belt mechanism

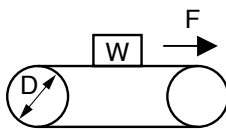

Traveling torque $T_f = \frac{D}{2\eta} (\mu g W + F)$

W : Weight [kg]

η : Mechanical efficiency

P : Pulley diameter [m]

μ : Coefficient of friction

F : External force [N]

g : Acceleration of gravity 9.8 [m/s²]

(3) Effective torque

Indicates a root-mean-square value of the total torque required for running and stopping the motor per unit time. The reference value is approx. 80 % or less of the rated motor torque.

$$T_{rms} = \sqrt{\frac{T_a^2 \times t_a + T_f^2 \times t_b + T_d^2 \times t_d}{t_c}}$$

T_a : Acceleration torque [N·m]

t_a : Acceleration time [s]

t_c : Cycle time [s]

T_f : Traveling torque [N·m]

t_b : Constant-velocity time [s]

(Run time + Stop time)

T_d : Deceleration torque [N·m]

t_d : Deceleration time [s]

2. Motor velocity

Maximum velocity

Maximum velocity of motor in operation: The reference value is the rated velocity or lower value.

When the motor runs at the maximum velocity, you must pay attention to the motor torque and temperature rise.

For actual calculation of motor velocity, see "Example of motor selection" described later.

Selecting motor capacity

Description on the items related to motor selection

3. Inertia and inertia ratio

Inertia is like the force to retain the current moving condition.

Inertia ratio is calculated by dividing load inertia by rotor inertia.

Generally, for motors with 750 W or lower capacity, the inertia ratio should be "20" or less. For motors with 1000 W or higher capacity, the inertia ratio should be "10" or less.

If you need quicker response, a lower inertia ratio is required.

(For example, when the motor takes several seconds in acceleration step, the inertia ratio can be further increased.)

General inertia calculation method

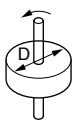
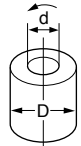
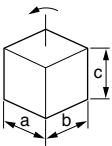
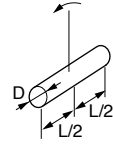
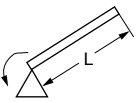
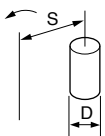
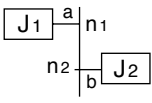
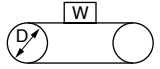
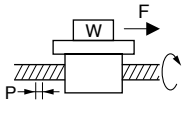
Shape	J calculation formula	Shape	J calculation formula
Disk 	$J = \frac{1}{8} W D^2 \text{ [kg}\cdot\text{m}^2\text{]}$ <p>W : Weight [kg] D : Outer diameter [m]</p>	Hollow cylinder 	$J = \frac{1}{8} W (D^2 + d^2) \text{ [kg}\cdot\text{m}^2\text{]}$ <p>W : Weight [kg] D : Outer diameter [m] d : Inner diameter [m]</p>
Prism 	$J = \frac{1}{12} W (a^2 + b^2) \text{ [kg}\cdot\text{m}^2\text{]}$ <p>W : Weight [kg] a, b, c : Side length [m]</p>	Uniform rod 	$J = \frac{1}{48} W (3D^2 + 4L^2) \text{ [kg}\cdot\text{m}^2\text{]}$ <p>W : Weight [kg] D : Outer diameter [m] L : Length [m]</p>
Straight rod 	$J = \frac{1}{3} W L^2 \text{ [kg}\cdot\text{m}^2\text{]}$ <p>W : Weight [kg] L : Length [m]</p>	Separated rod 	$J = \frac{1}{8} W D^2 + W S^2 \text{ [kg}\cdot\text{m}^2\text{]}$ <p>W : Weight [kg] D : Outer diameter [m] S : Distance [m]</p>
Reduction gear 	<p>Inertia on shaft "a"</p> $J = J_1 + \left(\frac{n_2}{n_1}\right)^2 J_2 \text{ [kg}\cdot\text{m}^2\text{]}$ <p>n₁ : A rotational speed of a shaft [r/min] n₂ : A rotational speed of b shaft [r/min]</p>		
Conveyor 	$J = \frac{1}{4} W D^2 \text{ [kg}\cdot\text{m}^2\text{]}$ <p>W : Workpiece weight on conveyor [kg] D : Drum diameter [m]</p> <p>* Excluding drum J</p>	Ball screw 	$J = J_B + \frac{W \cdot P^2}{4\pi^2} \text{ [kg}\cdot\text{m}^2\text{]}$ <p>W : Weight [kg] P : Lead [m] J_B : J of ball screw</p>

If weight (W [kg]) is unknown, calculate it with the following formula:

$$\text{Weight } W \text{ [kg]} = \text{Density } \rho \text{ [kg/m}^3\text{]} \times \text{Volume } V \text{ [m}^3\text{]}$$

Density of each material

$$\text{Iron } \rho = 7.9 \times 10^3 \text{ [kg/m}^3\text{]}$$

$$\text{Aluminum } \rho = 2.8 \times 10^3 \text{ [kg/m}^3\text{]}$$

$$\text{Brass } \rho = 8.5 \times 10^3 \text{ [kg/m}^3\text{]}$$

To drive ball screw mechanism

1. Example of motor selection for driving ball screw mechanism

Workpiece weight	WA = 10 [kg]
Ball screw length	BL = 0.5 [m]
Ball screw diameter	BD = 0.02 [m]
Ball screw lead	BP = 0.02 [m]
Ball screw efficiency	Bη = 0.9
Travel distance	0.3 [m]
Coupling inertia	Jc = 10 × 10⁻⁶ [kg·m ²] (Use manufacturer-specified catalog value, or calculation value.)

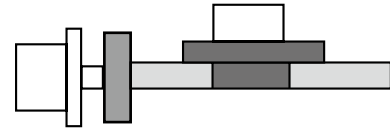

2. Running pattern :

Acceleration time	ta = 0.7 [s]
Constant-velocity time	tb = 1.3 [s]
Deceleration time	td = 0.7 [s]
Cycle time	tc = 4 [s]
Travel distance	0.3 [m]

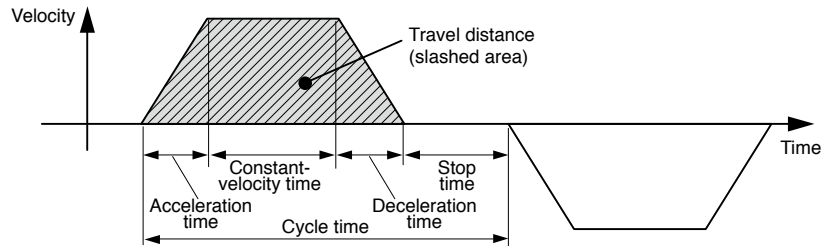

3. Ball screw weight

$$\begin{aligned} \mathbf{Bw} &= \rho \times \pi \times \left(\frac{\mathbf{BD}}{2}\right)^2 \times \mathbf{BL} = 7.9 \times 10^3 \times \pi \times \left(\frac{0.02}{2}\right)^2 \times 0.5 \\ &= 1.24 \text{ [kg]} \end{aligned}$$

4. Load inertia

$$\begin{aligned} \mathbf{JL} &= \mathbf{Jc} + \mathbf{JB} + \mathbf{Jw} = \mathbf{Jc} + \frac{1}{8} \mathbf{Bw} \times \mathbf{BD}^2 + \frac{\mathbf{WA} \cdot \mathbf{BP}^2}{4\pi^2} \\ &= 0.00001 + (1.24 \times 0.02^2) / 8 + 10 \times 0.02^2 / 4\pi^2 \\ &= 1.73 \times 10^{-4} \text{ [kg·m}^2\text{]} \end{aligned}$$

5. Provisional motor selection

In case of GP series 50 W, gear ratio 1/5. Permissible load inertia moment = 3.42×10^{-4} [kg·m²]

6. Inertia moment compared

Permissible load inertia moment = 3.42×10^{-4} [kg·m²] > Load inertia
= 1.73×10^{-4} [kg·m²] Cleared specification

7. Calculation of maximum velocity (Vmax)

$$\frac{1}{2} \times \text{Acceleration time} \times V_{\max} + \text{Constant-velocity time} \times V_{\max} + \frac{1}{2} \times \text{Deceleration time} \times V_{\max} = \text{Travel distance}$$

$$\frac{1}{2} \times 0.7 \times V_{\max} + 1.3 \times V_{\max} + \frac{1}{2} \times 0.7 \times V_{\max} = 0.3$$

$$2.0 \times V_{\max} = 0.3$$

$$V_{\max} = 0.3 / 2.0 = 0.15 \text{ [m/s]}$$

8. Calculation of motor velocity (N [r/min]) Ball screw lead per resolution: BP = 0.02 [m]

$$N = 0.15 / 0.02 = 7.5 \text{ [r/s]}$$

$$= 7.5 \times 60 = 450 \text{ [r/min]} < 600 \text{ [r/min]} \text{ (rated rotation speed of GP series 50 W, gear ratio 1/5)}$$

9. Calculation of torque

$$\begin{aligned} \text{Traveling torque } \mathbf{Tf} &= \frac{\mathbf{BP}}{2\pi\mathbf{B}\eta} (\mu\mathbf{gWA} + \mathbf{F}) = \frac{0.02}{2\pi \times 0.9} (0.1 \times 9.8 \times 10 + 0) \\ &= 0.035 \text{ [N·m]} \end{aligned}$$

$$\begin{aligned} \text{Acceleration torque } \mathbf{Ta} &= \frac{\mathbf{JL} \times 2\pi\mathbf{N} \text{ [r/s]}}{\text{Acceleration time [s]}} + \text{Traveling torque} = \frac{1.73 \times 10^{-4} \times 2\pi \times 7.5}{0.7} + 0.035 \\ &= 0.012 + 0.035 = 0.047 \text{ [N·m]} \end{aligned}$$

$$\begin{aligned} \text{Deceleration torque } \mathbf{Td} &= \frac{\mathbf{JL} \times 2\pi\mathbf{N} \text{ [r/s]}}{\text{Deceleration time [s]}} - \text{Traveling torque} = \frac{1.73 \times 10^{-4} \times 2\pi \times 7.5}{0.7} - 0.035 \\ &= 0.012 - 0.035 = -0.023 \text{ [N·m]} \end{aligned}$$

Selecting motor capacity

10. Verification of maximum torque

Acceleration torque = T_a

= 0.047 [N·m] < 0.71 [N·m] (GP series 50 W, 1/5 gear, Permissible torque at output shaft of gear head)

11. Verification of effective torque

$$T_{rms} = \sqrt{\frac{T_a^2 \times t_a + T_f^2 \times t_b + T_d^2 \times t_d}{t_c}}$$

$$= \sqrt{\frac{0.047^2 \times 0.7 + 0.035^2 \times 1.3 + (-0.023)^2 \times 0.7}{4}}$$

= 0.030 [N·m] < 0.71 [N·m] (GP series 50 W, 1/5 gear, Permissible torque at output shaft of gear head)

12. Load torque, load inertia moment are cleared specification.

Example of motor selection for timing belt mechanism

1. Mechanism

Workpiece weight

$W_A = 2$ [kg] (including belt)

Pulley diameter

$P_D = 0.05$ [m]

Pulley weight

$W_P = 0.5$ [kg] (Use manufacturer-specified catalog value, or calculation value.)

Mechanical efficiency

$B_\eta = 0.8$

Coupling inertia

$J_c = 0$ (Direct connection to motor shaft)

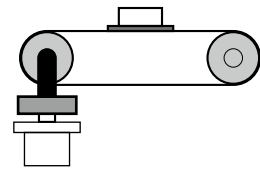

2. Running pattern

Acceleration time

$t_a = 1.0$ [s]

Constant-velocity time

$t_b = 1.0$ [s]

Deceleration time

$t_d = 1.0$ [s]

Cycle time

$t_c = 4$ [s]

Travel distance 1 [m]

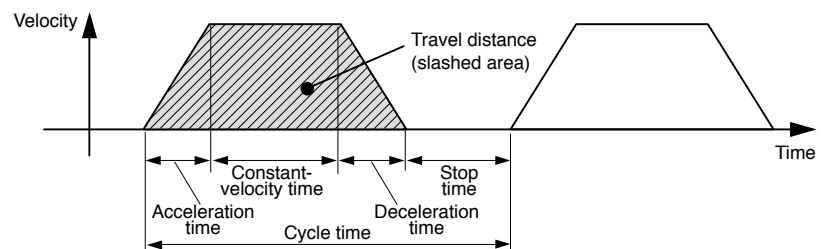

3. Load inertia

$$J_L = J_c + J_B + J_P$$

$$= J_c + \frac{1}{4} W_A \times P_D^2 + \frac{1}{8} W_P \times P_D^2 \times 2$$

$$= 0 + \frac{1}{4} \times 2 \times 0.05^2 + \frac{1}{8} \times 0.5 \times 0.05^2 \times 2$$

$$= 0.00156 = 15.6 \times 10^{-4} \text{ [kg}\cdot\text{m}^2\text{]}$$

4. Provisional motor selection

In case of GP series 50 W, gear ratio 1/15. Permissible load inertia moment = 30.6×10^{-4} [kg·m²]

5. Inertia moment compared

30.6×10^{-4} [kg·m²] > 15.6×10^{-4} [kg·m²]

6. Calculation of maximum velocity (Vmax)

$$\frac{1}{2} \times \text{Acceleration time} \times V_{\max} + \text{Constant-velocity time} \times V_{\max} + \frac{1}{2} \times \text{Deceleration time} \times V_{\max} = \text{Travel distance}$$

$$\frac{1}{2} \times 1.0 \times V_{\max} + 1.0 \times V_{\max} + \frac{1}{2} \times 1.0 \times V_{\max} = 1$$

$$2.0 \times V_{\max} = 1$$

$$V_{\max} = 1 / 2.0 = 0.5 \text{ [m/s]}$$

7. Calculation of motor velocity (N [r/min])

$$\text{A single rotation of pulley} : \pi \times P_D = 0.157 \text{ [m]}$$

$$N = 0.5 / 0.157 = 3.18 \text{ [r/s]}$$

$$= 3.18 \times 60 = 191 \text{ [r/min]} < 200 \text{ [r/min]} \text{ (rated rotation speed of GP series 50 W, gear ratio 1/15)}$$

8. Calculation of torque

$$\begin{aligned} \text{Traveling torque } T_f &= \frac{P_D}{2\eta} (\mu g W_A + F) = \frac{0.05}{2 \times 0.8} (0.1 \times 9.8 \times 2 + 0) \\ &= 0.061 \text{ [N}\cdot\text{m]} \end{aligned}$$

$$\begin{aligned} \text{Acceleration torque } T_a &= \frac{JL \times 2\pi N \text{ [r/s]}}{\text{Acceleration time [s]}} + \text{Traveling torque} \\ &= \frac{15.6 \times 10^{-4} \times 2\pi \times 3.18}{1.0} + 0.061 \\ &= 0.031 + 0.061 = 0.092 \text{ [N}\cdot\text{m]} \end{aligned}$$

$$\begin{aligned} \text{Deceleration torque } T_d &= \frac{JL \times 2\pi N \text{ [r/s]}}{\text{Deceleration time [s]}} - \text{Traveling torque} \\ &= \frac{15.6 \times 10^{-4} \times 2\pi \times 3.18}{1.0} - 0.061 \\ &= 0.031 - 0.061 = -0.03 \text{ [N}\cdot\text{m]} \end{aligned}$$

9. Verification of maximum torque

Acceleration torque

$$T_a = 0.092 \text{ [N}\cdot\text{m]} < 2.2 \text{ [N}\cdot\text{m]} \text{ (GP series 50 W, 1/15 gear, Permissible torque at output shaft of gear head)}$$

10. Verification of effective torque

$$\begin{aligned} T_{\text{rms}} &= \sqrt{\frac{T_a^2 \times t_a + T_f^2 \times t_b + T_d^2 \times t_d}{t_c}} \\ &= \sqrt{\frac{0.092^2 \times 1.0 + 0.061^2 \times 1.0 + (-0.03)^2 \times 1.0}{4}} \end{aligned}$$

$$= 0.057 \text{ [N}\cdot\text{m]} < 2.2 \text{ [N}\cdot\text{m]} \text{ (GP series 50 W, 1/15 gear, Permissible torque at output shaft of gear head)}$$

11. A GP series 50 W, 1/15 gear selected by following the above procedure will cause no problem.

Request sheet for motor selection

Request for motor selection I : Ball screw drive

1. Driven mechanism and running data

- | | | |
|---|------------|------|
| 1) Travel distance of the work load per one cycle | ℓ_1 : | mm |
| 2) Cycle time | to: | s |
| (Fill in items 3) and 4) if required.) | | |
| 3) Acceleration time | ta: | s |
| 4) Deceleration time | td: | s |
| 5) Stopping time | ts: | s |
| 6) Max. velocity | V: | mm/s |
| 7) External force | F: | N |
| 8) Positioning accuracy of the work load | \pm | mm |
| 9) Total weight of the work load and the table | WA: | kg |
| 10) Power supply voltage | | V |
| 11) Diameter of the ball screw | | mm |
| 12) Total length of the ball | | mm |
| 13) Lead of the ball screw | | mm |

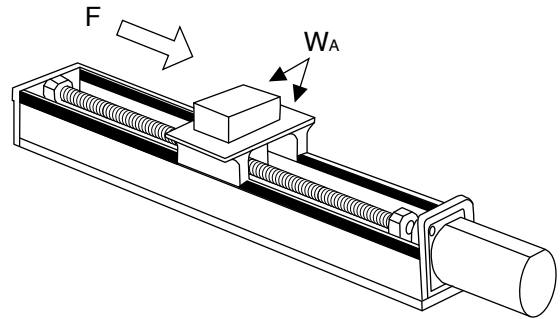
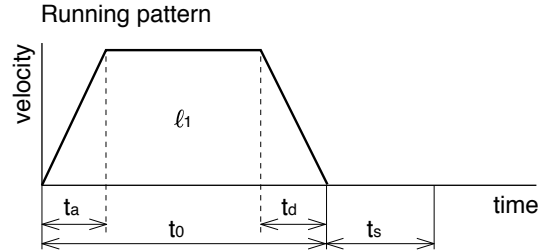

14) Traveling direction (horizontal, vertical etc.)

2. Other data (Fill the details on specific mechanism and its configurations in the following blank.)

Company name : _____

Department/Section : _____

Name : _____

Address : _____

Tel : _____

Fax : _____

E-mail address: _____

Request sheet for motor selection

Request for motor selection II : Timing pulley + Ball screw drive

1. Driven mechanism and running data

		Motor side	Ball screw side
1) Travel distance of the work load per one cycle	l_1 : mm	15) Diameter of the pulley D1: mm	D2: mm
2) Cycle time	t_0 : s	16) Weight of the pulley W1: kg	W2: kg
(Fill in items 3) and 4) if required.)		(or item 17) and 18))	
3) Acceleration time	t_a : s	17) Width of the pulley L1: mm	
4) Deceleration time	t_d : s	18) Material of the pulley	
5) Stopping time	t_s : s	19) Weight of the belt W _M : kg	
6) Max. velocity	V: mm/s		
7) External force	F: N		
8) Positioning accuracy of the work load	± mm		
9) Total weight of the work load and the table	W _A : kg		
10) Power supply voltage	V		
11) Diameter of the ball screw	mm		
12) Total length of the ball screw	mm		
13) Lead of the ball screw	mm		
14) Traveling direction (horizontal, vertical etc.)			

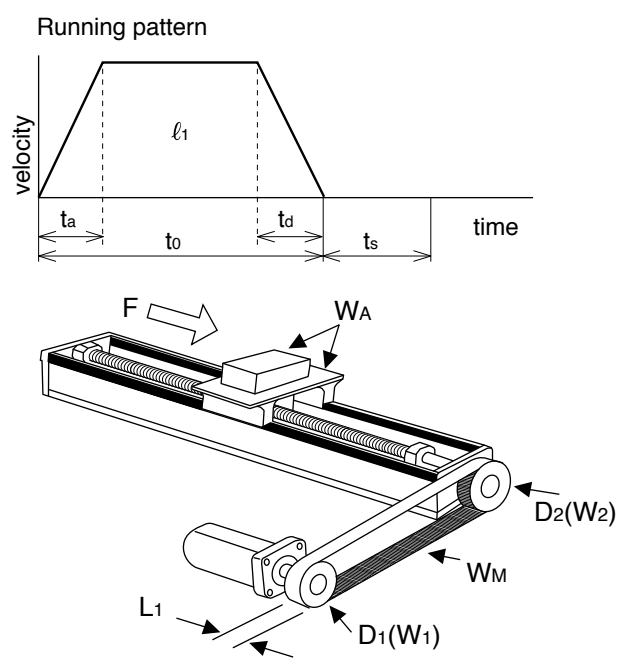

2. Other data (Fill the details on specific mechanism and its configurations in the following blank.)

Company name : _____

Department/Section : _____

Name : _____

Address : _____

Tel : _____

Fax : _____

E-mail address: _____

GV series
KV series
GP series
Options
Information

Request sheet for motor selection

Request for motor selection III : Belt drive

1. Driven mechanism and running data

- | | | |
|---|---------|------|
| 1) Travel distance of the work load per one cycle | l_1 : | mm |
| 2) Cycle time | t_0 : | s |
| (Fill in items 3) and 4) if required.) | | |
| 3) Acceleration time | t_a : | s |
| 4) Deceleration time | t_d : | s |
| 5) Stopping time | t_s : | s |
| 6) Max. velocity | V: | mm/s |
| 7) External force | F: | N |
| 8) Positioning accuracy of the work load | \pm | mm |
| 9) Total weight of the work load | W_A : | kg |
| 10) Power supply voltage | | V |
| 11) Weight of the belt | W_M : | kg |
| 12) Diameter of the driving pulley | D_1 : | mm |
| 13) Total weight of the pulley | W_1 : | kg |

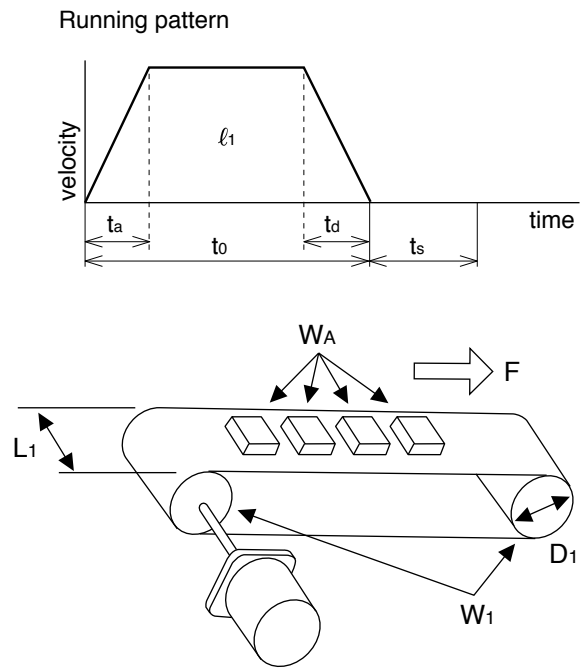

(or item 14) and 15))

- | | | |
|---|---------|----|
| 14) Width of the pulley | L_1 : | mm |
| 15) Material of the pulley | | |
| 16) Traveling direction (horizontal, vertical etc.) | | |

2. Other data (Fill the details on specific mechanism and its configurations in the following blank.)

Company name : _____

Department/Section : _____

Name : _____

Address : _____

Tel : _____

Fax : _____

E-mail address: _____

Request sheet for motor selection

Request for motor selection IV : Timing pulley + Belt drive

1. Driven mechanism and running data

- | | | |
|---|------------|------|
| 1) Travel distance of the work load per one cycle | ℓ_1 : | mm |
| 2) Cycle time | t_0 : | s |
| (Fill in items 3) and 4) if required.) | | |
| 3) Acceleration time | t_a : | s |
| 4) Deceleration time | t_d : | s |
| 5) Stopping time | t_s : | s |
| 6) Max. velocity | V: | mm/s |
| 7) External force | F: | N |
| 8) Positioning accuracy of the work load | \pm | mm |
| 9) Total weight of the work load and the table | W_A : | kg |
| 10) Power supply voltage | | V |
| 11) Weight of motor side belt | W_M : | kg |

- | | Motor side | Belt side |
|---|------------|-----------|
| 16) Diameter of the pulley | D3: mm | D4: mm |
| 17) Weight of the pulley | W3: kg | W4: kg |
| (or item 18) and 19)) | | |
| 18) Width of the pulley | L2: mm | |
| 19) Material of the pulley | | |
| 20) Weight of the belt | W_M : kg | |
| 21) Traveling direction (horizontal, vertical etc.) | | |

Running pattern

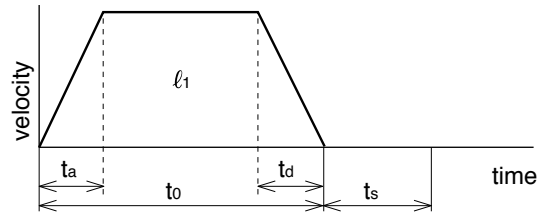

- | | Motor side | Belt side |
|----------------------------|------------|-----------|
| 12) Diameter of the pulley | D1: mm | D2: mm |
| 13) Weight of the pulley | W1: kg | W2: kg |
| (or item 14) and 15)) | | |
| 14) Width of the belt | L1: mm | |
| 15) Material of the pulley | | |

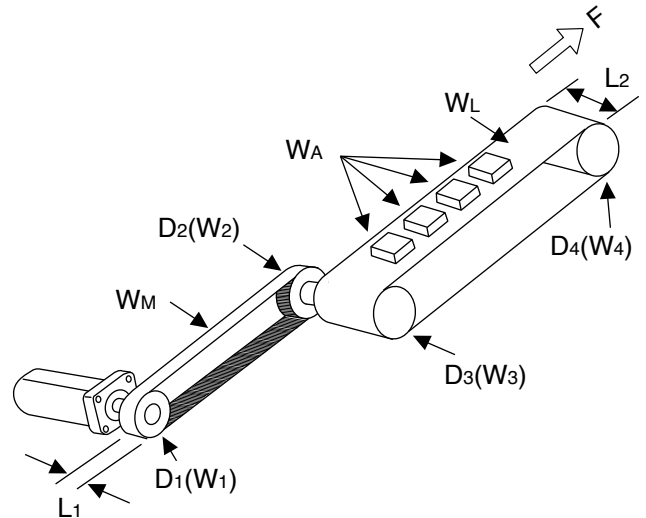

2. Other data (Fill the details on specific mechanism and its configurations in the following blank.)

	<p>Company name : _____</p> <p>Department/Section : _____</p> <p>Name : _____</p> <p>Address : _____</p> <p>Tel : _____</p> <p>Fax : _____</p> <p>E-mail address: _____</p>
--	---

GV series
KV series
GP series
Options
Information

Request sheet for motor selection

Request for motor selection V : Turntable drive

1. Driven mechanism and running data

1) Travel distance of the work load per one cycle	d ₁ :	deg	
2) Cycle time	t ₀ :	s	
(Fill in items 3) and 4) if required.)			
3) Acceleration time	t _a :	s	
4) Deceleration time	t _d :	s	
5) Stopping time	t _s :	s	
6) Max. rotational speed of the table	v:	deg/s	
	(or)	V:	r/s
7) Positioning accuracy of the work load	±	deg	
8) Weight of one work load	W _A :	kg	
9) Driving radius of the center of gravity of the work	R ₁ :	mm	
10) Diameter of the table	D ₁ :	mm	
11) Mass of the table	W ₁ :	kg	
12) Diameter of the table support	T ₁ :	mm	
13) Power supply voltage			V

14) Dimensions of the work load		Prism	Cylinder	
	a:	mm	a:	mm
	b:	mm	b:	mm
	c:	mm	c:	mm
15) Number of work loads	pcs			

Running pattern

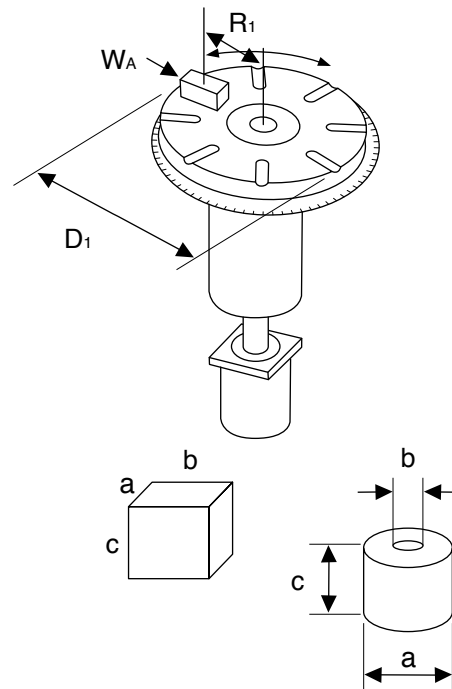
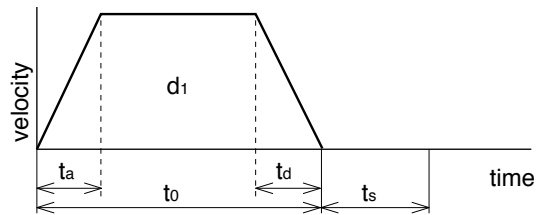

2. Other data (Fill the details on specific mechanism and its configurations in the following blank.)

<div style="border: 1px solid black; padding: 5px; margin-top: 10px;"> Company name : _____ Department/Section : _____ Name : _____ Address : _____ Tel : _____ Fax : _____ E-mail address: _____ </div>	
--	--

Request sheet for motor selection

Request for motor selection VI : Timing pulley + Turntable drive

1. Driven mechanism and running data

		Motor side	Turntable side			
1) Travel distance of the work load per one cycle	d ₁ : deg	16) Diameter of the pulley	D ₂ : mm D ₃ : mm			
2) Cycle time	to: s	17) Weight of the pulley	W ₂ : kg W ₃ : kg			
(Fill in items 3) and 4) if required.)		(or item 18) and 19))				
3) Acceleration time	ta: s	18) Width of the pulley	L1: mm			
4) Deceleration time	td: s	19) Material of the pulley				
5) Stopping time	ts: s	20) Weight of the belt	W _M : kg			
6) Max. rotational speed of the table	v: deg/s	<div style="text-align: center;">Running pattern</div>				
(or)	V: r/s					
7) Positioning accuracy of the work load	± deg					
8) Weight of one work load	W _A : kg					
9) Driving radius of the center of gravity of the work	R ₁ : mm					
10) Diameter of the table	D ₁ : mm					
11) Mass of the table	W ₁ : kg					
12) Diameter of the table support	T ₁ : mm					
13) Power supply voltage				v		
14) Dimension of the work load	(Prism) (Cylinder)					
	a: mm			a: mm		
	b: mm			b: mm		
	c: mm	c: mm				
15) Number of work loads		pcs				

2. Other data (Fill the details on specific mechanism and its configurations in the following blank.)

	Company name : _____ Department/Section : _____ Name : _____ Address : _____ Tel : _____ Fax : _____ E-mail address: _____
--	--

GV series
 KV series
 GP series
 Options
 Information

Request sheet for motor selection

Request for motor selection VII : Roller feed drive

1. Driven mechanism and running data

1) Travel distance of the work load per one cycle	l_1 :	mm
2) Cycle time	t_0 :	s
(Fill in items 3) and 4) if required.)		
3) Acceleration time	t_a :	s
4) Deceleration time	t_d :	s
5) Stopping time	t_s :	s
6) Max. velocity	v :	mm/s
7) External pulling force	F :	N
8) Positioning accuracy of the work load	\pm	mm
9) Number of rollers		pcs
10) Power supply voltage		V
11) Diameter of the roller	D_1 :	mm
12) Mass of the roller	W_1 :	kg

Running pattern

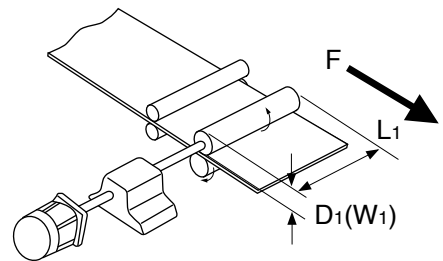
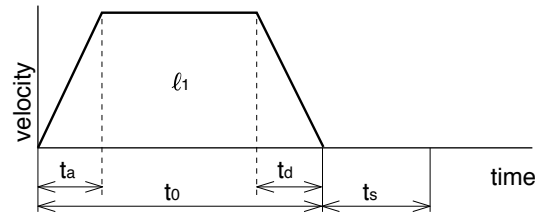

(or item 13) and 14))

13) Width of the roller	L_1 :	mm
14) Material of the roller		

2. Other data (Fill the details on specific mechanism and its configurations in the following blank.)

Company name : _____

Department/Section : _____

Name : _____

Address : _____

Tel : _____

Fax : _____

E-mail address: _____

Request sheet for motor selection

Request for motor selection VIII : Driving with Rack & Pinion

1. Driven mechanism and running data

- | | | |
|--|---------|------|
| 1) Travel distance of the work load per one cycle | l_1 : | mm |
| 2) Cycle time | t_0 : | s |
| (Fill in items 3) and 4) if required.) | | |
| 3) Acceleration time | t_a : | s |
| 4) Deceleration time | t_d : | s |
| 5) Stopping time | t_s : | s |
| 6) Max. velocity | V: | mm/s |
| 7) External force | F: | N |
| 8) Positioning accuracy of the work load | \pm | mm |
| 9) Total weight of the work load | W_A : | kg |
| 10) Power supply voltage | | V |
| 11) Diameter of the pinion | D_3 : | mm |
| 12) Mass of the pinion | W_3 : | kg |
| 13) Traveling direction (horizontal, vertical, etc.) | | |

Running pattern

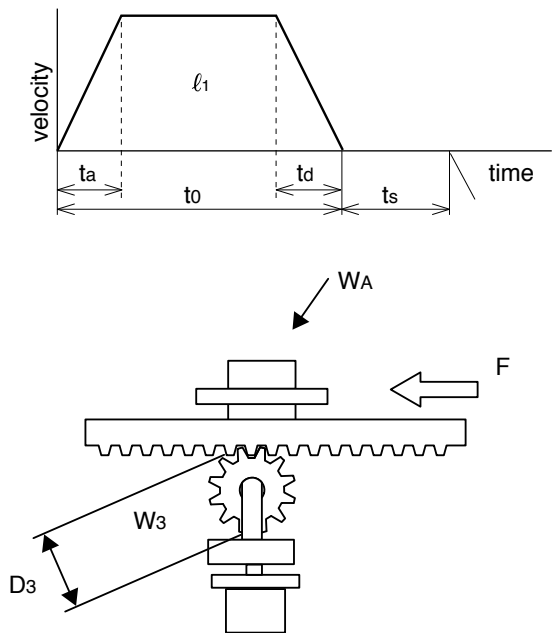

2. Other data (Fill the details on specific mechanism and its configurations in the following blank.)

Company name : _____

Department/Section : _____

Name : _____

Address : _____

Tel : _____

Fax : _____

E-mail address: _____

Conformance to international safety standards

Conformance to international standards (KV series : Under application)

EC Directives

The EC directives apply to all such electronic products as those having specific functions and directly sold to general consumers in EU countries. These products are required to meet the EU unified standards and to be furnished with CE marking. Our brushless motor and brushless amplifier meet the EC Directives for Low Voltage Equipment so that the machine or equipment comprising our brushless motor and brushless amplifier can meet relevant EC Directives.

Conformity to UL Standards

Observe the following conditions of (1) and (2) to make the system conform to UL508C (E164620).

- (1) Use the driver in an environment of Pollution Degree 2 or 1 prescribed in IEC60664-1.
(e.g. Install in the control box with IP54 enclosure.)
- (2) Make sure to install a circuit breaker or fuse which are UL recognized (Listed  marked) between the power supply and the noise filter.
Use a copper cable with temperature rating of 75 °C or higher.

EMC Directives

Our brushless motor and brushless amplifier can meet EMC Directives and related standards. However, to meet these requirements, the systems must be limited with respect to configuration and other aspects, e.g. the installation and some special wiring conditions must be met. This means that in some cases machines and equipment comprising our brushless motor and brushless amplifier may not satisfy the requirements for wiring and grounding conditions specified by the EMC Directives. Therefore, conformance to the EMC Directives (especially the requirements for emission noise and noise terminal voltage) should be examined based on the final products that include our system.

	Applicable standards		Installation condition
UL	UL1004 UL508C	Standard for electric motor Standard for electric converter equipment	Class I equipment Pollution degree 2 SCCR *1
CSA (c-UL)	C22.2 No.100	Standard for electric motor	
CE	EN61800-5-1	Adjustable speed electrical power drive systems. – Safety requirements. Electrical, thermal and energy	Overvoltage category II Class I equipment Pollution degree 2
	EN60034-1	Standard for rotary electric machine (low voltage directive)	
	EN60034-5	Standard for rotary electric machine (low voltage directive)	
	EN61800-3	Adjustable speed electrical power drive systems. – EMC requirements and specific test methods	
	EN55011	Radio interference wave characteristics of industrial, scientific, and medical high-frequency equipment	
	EN61000-6-2	Standards for immunity in industrial environment (EMC directive)	
CCC	GB12350	Motor safety standard	
KC	Korea Radio Law *2	Class A Instrument (commercial broadcast communications equipment)	—

*1 SCCR: Symmetrical current 5,000 Arms, Max. 240 V

Motor over-temperature protection is not provided.

Motor over-load-temperature protection shall be provided at the final installation upon required by the NEC (National Electric Code).

*2 Information related to the Korea Radio Law

This brushless amplifier is a Class A commercial broadcasting radio wave generator not designed for home use. The user and dealer should be aware of this fact.

A 급 기기 (업무용 방송통신기자재)

이 기기는 업무용(A 급) 전자파적합기기로서 판매자 또는 사용자는 이 점을 주의하시기 바라며, 가정외의 지역에서 사용하는 것을 목적으로 합니다.

(대상기종 : Brushless Amplifier)

Configuration of peripheral equipment

Power supply	<ul style="list-style-type: none"> • 100 V system: Single phase 100 V ± 10 % to 120 V ± 10 %, 50/60 Hz • 200 V system: Single/3-phase 200 V ± 10 % to 240 V ± 10 %, 50/60 Hz • Use the equipment under the environment of overvoltage category II specified by IEC60664-1. In order to obtain overvoltage category III, insert a transformer conforming to EN standard or IEC standard to the input of brushless motor. • Use an electric wire size suitable to EN60204-1.
MCCB (breaker) Fuse	Be sure to connect a specified MCCB certified by IEC standard and UL, or a fuse certified by UL between power supply and noise filter. Observance of this condition allows conformance with UL508C (file No. E164620) .
Noise filter	When installing one noise filter at the power supply for more than one brushless motor used, contact the manufacturer of noise filter.
Surge absorber	Install a surge absorber on the primary side of noise filter. However, in performing the voltage resistance test of machine and equipment, be sure to remove the surge absorber; otherwise, the surge absorber may be ruptured.
Grounding	Be sure to connect the grounding Terminal of brushless amplifier and protective grounding wire (PE) of system for preventing electric shock. Do not tighten the grounding wires together but connect them individually.

Wiring of peripheral equipment

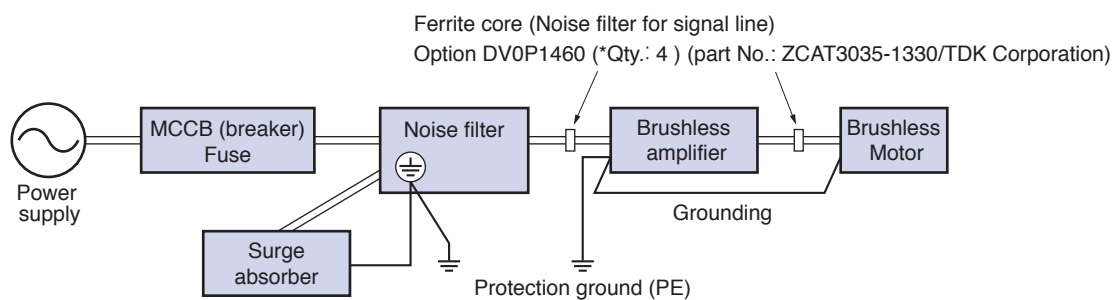

* The ferrite core should insert one or more pieces in an electric wire, respectively.

List of compatible peripheral equipment

Part name	Optional parts number (option)	Manufacturer's parts number	Qty.	Manufacturer	Reference page
Noise filter (single phase 100 V, 200 V)	DV0P4170	SUP-EK5-ER-6	1	OKAYA ELECTRIC IND. CO., LTD.	P.67
Noise filter (3-phase)	DV0PM20042	3SUP-HU10-ER-6	1		
Surge absorber (single phase 100 V, 200 V)	DV0P4190	R•A•V-781BWZ-4	1		
Surge absorber (3-phase)	DV0P1450	R•A•V-781BXZ-4	1		
Noise filter for control signals	DV0P1460	ZCAT3035-1330	4	TDK Corporation	

Table of model numbers and options

■ GV series

Power supply	Rated rotation speed (r/min)	output (W)	Motor	Gear head (Note 1)	Brushless amplifier	Brushless amplifier (supplied with power cable) (Note 2)	External regenerative resistor	Noise filter	Surge absorber	Reactor
Single phase 100 V	3000	50	MBMU5AZAX	MX8G□B	MBEG5A1BCV	MBEG5A1BCVC	for 100 V DV0P2890	for single phase power supply DV0P4170	for single phase power supply DV0P4190	for single phase power supply DV0P227
			MBMU5AZAS	—						
		90	MBMU9A1AZ	MZ9G□B MY9G□B	MBEG9A1BCV	MBEG9A1BCVC				
			MBMU9A1AS	—						
		130	MBMU1E1AZ	MZ9G□B MY9G□B	MBEG1E1BCV	MBEG1E1BCVC				
			MBMU1E1AS	—						
Single phase/ 3-phase 200 V	3000	50	MBMU5AZAX	MX8G□B	MBEG5A5BCV	MBEG5A5BCVC	for 200 V DV0PM20068	for single phase power supply DV0P4170 for 3-phase power supply DV0PM20042	for single phase power supply DV0P4190	for single phase power supply DV0P227 for 3-phase power supply DV0P220
			MBMU5AZAS	—						
		90	MBMU9A2AZ	MZ9G□B MY9G□B	MBEG9A5BCV	MBEG9A5BCVC				
			MBMU9A2AS	—						
		130	MBMU1E2AZ	MZ9G□B MY9G□B	MBEG1E5BCV	MBEG1E5BCVC				
			MBMU1E2AS	—						

■ KV series

Power supply	Rated rotation speed (r/min)	output (W)	Motor (Note 3)	Gear head	Brushless amplifier	Brushless amplifier (supplied with power cable) (Note 2)	External regenerative resistor	Noise filter	Surge absorber	Reactor			
Single phase 100 V	3000	50	MBMS5AZBLO	—	MBEK5A1BCV	MBEK5A1BCVC	for 100 V DV0P2890	for single phase power supply DV0P4170	for single phase power supply DV0P4190	for single phase power supply DV0P227			
		100	MBMS011BLO		MBEK011BCV	MBEK011BCVC				for single phase power supply DV0P228			
		200	MBMS021BLO		MBEK021BCV	—				for single phase power supply DV0P227			
Single phase/ 3-phase 200 V		50	MBMS5AZBLO		MBEK5A5BCV	MBEK5A5BCVC	for 200 V DV0PM20068			for single phase power supply DV0P4170 for 3-phase power supply DV0PM20042	for 3-phase power supply DV0P1450	for 3-phase power supply DV0P1450	for single phase power supply DV0P227
		100	MBMS012BLO		MBEK015BCV	MBEK015BCVC							for 3-phase power supply DV0P220
3-phase 200 V		200	MBMS022BLO		MBEK025BCV	—							for 3-phase power supply DV0P220
	400	MBMS042BLO	MBEK043BCV	—	for 3-phase power supply DV0P220								
	750	MBMS082BLO	MBEK083BCV	—	for 3-phase power supply DV0P220								

■ GP series

Power supply	Rated rotation speed (r/min)	output (W)	Motor	Gear head (Note 1)	Brushless amplifier	Brushless amplifier (supplied with power cable) (Note 2)	External regenerative resistor	Noise filter	Surge absorber	Reactor					
Single phase 100 V	3000	50	MBMU5AZAB	MB8G□BV	MBEG5A1BCP	MBEG5A1BCPC	for 100 V DV0P2890	for single phase power supply DV0P4170	for single phase power supply DV0P4190	for single phase power supply DV0P227					
		90	MBMU9A1AB	MB9G□BV							MBEG9A1BCP	MBEG9A1BCPC			
		130	MBMU1E1AB	MB9G□BV									MBEG1E1BCP	MBEG1E1BCPC	
Single phase/ 3-phase 200 V		50	MBMU5AZAB	MB8G□BV	MBEG5A5BCP	MBEG5A5BCPC	for 200 V DV0PM20068				for single phase power supply DV0P4170 for 3-phase power supply DV0PM20042	for single phase power supply DV0P4190			for single phase power supply DV0P227 for 3-phase power supply DV0P220
		90	MBMU9A2AB	MB9G□BV									MBEG9A5BCP	MBEG9A5BCPC	
		130	MBMU1E2AB	MB9G□BV											

(Note 1) A figure representing reduction ratio in □ .

(Note 2) Refer to p. 74 for a power supply connecting cable.

This part number is the ordering part number for the amplifier and power cable, not for ordering amplifier only.

(Note 3) Suffix of "○" in the motor model represents shape of shaft. For more information, please refer to p. 27.

(Note 4) When connecting PC, the PC connection cable (DV0P4140) and the Digital key pad connection cable (DV0P383*0) are required.

If your PC does not have RS232 port, use RS232-USB converter.

- When installing the reactor, refer to p. 73.
- Be sure to use a set of matched components (series, power source, capacity, output, etc.)

	Motor extension cable	Power supply connector kit	Console A	Console A connection cable	Digital key pad	Digital key pad connection cable	External speed setter	Control signal cable	I/O connector kit	Panel connector kit	PC connection cable (Note 4)	Noise filter for signal line	DIN rail attachment unit
	1 m DV0PQ1000110 3 m DV0PQ1000130 5 m DV0PQ1000150 10 m DV0PQ10001A1	DV0P2870	DV0P3500	1 m DV0PM2006910 3 m DV0PM2006930 5 m DV0PM2006950	DV0P3510	1 m DV0P38310 3 m DV0P38330 5 m DV0P38350	DV0PM20078	2 m DV0PM20076	DV0PM20070	DV0P3610	1.5 m DV0P4140	DV0P1460	DV0P3811

	Motor extension cable	Power supply connector kit	Console A	Console A connection cable	Digital key pad	Digital key pad connection cable	External speed setter	Control signal cable	I/O connector kit	Panel connector kit	PC connection cable (Note 4)	Noise filter for signal line	DIN rail attachment unit
	1 m DV0PQ1000310 3 m DV0PQ1000330 5 m DV0PQ1000350 10 m DV0PQ10003A1	DV0P2870 — DV0P2870 —	DV0P3500	1 m DV0PM2006910 3 m DV0PM2006930 5 m DV0PM2006950	DV0P3510	1 m DV0P38310 3 m DV0P38330 5 m DV0P38350	DV0PM20078	2 m DV0PM20076	DV0PM20070	DV0P3610	1.5 m DV0P4140	DV0P1460	DV0P3811 — DV0P3811 —

	Motor extension cable	Power supply connector kit	Console A	Console A connection cable	Digital key pad	Digital key pad connection cable	External speed setter	Control signal cable	I/O connector kit	Panel connector kit	PC connection cable (Note 4)	Noise filter for signal line	DIN rail attachment unit
	1 m DV0PQ1000110 3 m DV0PQ1000130 5 m DV0PQ1000150 10 m DV0PQ10001A1	DV0P2870	—	—	DV0P3510	1 m DV0P38310 3 m DV0P38330 5 m DV0P38350	—	2 m DV0PM20076	DV0PM20070	—	1.5 m DV0P4140	DV0P1460	DV0P3811

- GV series
- KV series
- GP series
- Options
- Information

Index

Model No.	Specifications	Page
DV0P (Option)		
DV0P1450	Surge absorber (3-phase)	67
DV0P1460	Noise filter for control signals	67
DV0P220	Reactor	73
DV0P227	Reactor	73
DV0P228	Reactor	73
DV0P2870	Power supply connector kit	70
DV0P2890	External regenerative resistor 50 Ω for 100 V	71
DV0P3500	Console A	68
DV0P3510	Digital key pad	68
DV0P3610	Panel connector kit (Fits to Console A)	71
DV0P3811	DIN rail attachment unit	72
DV0P38310	Digital key pad connection cable 1 m	68
DV0P38330	Digital key pad connection cable 3 m	68
DV0P38350	Digital key pad connection cable 5 m	68
DV0P4140	PC connection cable (10-pin D-sub connector pin 1.5 m)	70
DV0P4170	Noise filter (single phase)	67
DV0P4190	Surge absorber (single phase)	67
DV0PM20042	Noise filter (3-phase)	67
DV0PM20068	External regenerative resistor 200 Ω for 200 V	71
DV0PM2006910	Console A connection cable 1 m	68
DV0PM2006930	Console A connection cable 3 m	68
DV0PM2006950	Console A connection cable 5 m	68
DV0PM20070	I/O connector kit	71
DV0PM20076	Control signal cable (cable with I/O connector)	70
DV0PM20078	External speed setter	71
DV0PQ1000110	Motor extension cable 1 m for GV, GP series	69
DV0PQ1000130	Motor extension cable 3 m for GV, GP series	69
DV0PQ1000150	Motor extension cable 5 m for GV, GP series	69
DV0PQ10001A1	Motor extension cable 10 m for GV, GP series	69
DV0PQ1000310	Motor extension cable 1 m for KV series	69
DV0PQ1000330	Motor extension cable 3 m for KV series	69
DV0PQ1000350	Motor extension cable 5 m for KV series	69
DV0PQ10003A1	Motor extension cable 10 m for KV series	69

Model No.	Specifications	Page
MB8G (For GP series gear head)		
MB8G10BV	80 mm sq. Reduction ratio: 1/10	57,63
MB8G15BV	80 mm sq. Reduction ratio: 1/15	57,63
MB8G20BV	80 mm sq. Reduction ratio: 1/20	57,63
MB8G30BV	80 mm sq. Reduction ratio: 1/30	57,63
MB8G50BV	80 mm sq. Reduction ratio: 1/50	57,63
MB8G5BV	80 mm sq. Reduction ratio: 1/5	57,63

Model No.	Specifications	Page
MB9G (For GP series gear head)		
MB9G10BV	90 mm sq. Reduction ratio: 1/10	59,61,63
MB9G15BV	90 mm sq. Reduction ratio: 1/15	59,61,63
MB9G20BV	90 mm sq. Reduction ratio: 1/20	59,61,63
MB9G30BV	90 mm sq. Reduction ratio: 1/30	59,61,63
MB9G50BV	90 mm sq. Reduction ratio: 1/50	59,61,63
MB9G5BV	90 mm sq. Reduction ratio: 1/5	59,61,63

Model No.	Specifications	Page
MBEG (For GP series amplifier)		
MBEG1E1BCP	130 W Single phase 100 V to 120 V	61
MBEG1E1BCPC	130 W Single phase 100 V to 120 V (Power cable included)*	61
MBEG1E5BCP	130 W Single/3-Phase 200 V to 240 V	61
MBEG1E5BCPC	130 W Single/3-Phase 200 V to 240 V (Power cable included)*	61
MBEG5A1BCP	50 W Single phase 100 V to 120 V	57
MBEG5A1BCPC	50 W Single phase 100 V to 120 V (Power cable included)*	57
MBEG5A5BCP	50 W Single/3-Phase 200 V to 240 V	57
MBEG5A5BCPC	50 W Single/3-Phase 200 V to 240 V (Power cable included)*	57
MBEG9A1BCP	90 W Single phase 100 V to 120 V	59
MBEG9A1BCPC	90 W Single phase 100 V to 120 V (Power cable included)*	59
MBEG9A5BCP	90 W Single/3-Phase 200 V to 240 V	59
MBEG9A5BCPC	90 W Single/3-Phase 200 V to 240 V (Power cable included)*	59

* This part number is the ordering part number for the amplifier and power cable, not for ordering amplifier only.

Model No.	Specifications	Page
MBEG (For GV series amplifier)		
MBEG9A1BCV	90 W Single phase 100 V to 120 V	19
MBEG9A1BCVC	90 W Single phase 100 V to 120 V (Power cable included)*	19
MBEG9A5BCV	90 W Single/3-Phase 200 V to 240 V	19
MBEG9A5BCVC	90 W Single/3-Phase 200 V to 240 V (Power cable included)*	19
MBEG5A1BCV	50 W Single phase 100 V to 120 V	17
MBEG5A1BCVC	50 W Single phase 100 V to 120 V (Power cable included)*	17
MBEG5A5BCV	50 W Single/3-Phase 200 V to 240 V	17
MBEG5A5BCVC	50 W Single/3-Phase 200 V to 240 V (Power cable included)*	17
MBEG1E1BCV	130 W Single phase 100 V to 120 V	21
MBEG1E1BCVC	130 W Single phase 100 V to 120 V (Power cable included)*	21
MBEG1E5BCV	130 W Single/3-Phase 200 V to 240 V	21
MBEG1E5BCVC	130 W Single/3-Phase 200 V to 240 V (Power cable included)*	21

* This part number is the ordering part number for the amplifier and power cable, not for ordering amplifier only.

Model No.	Specifications	Page
-----------	----------------	------

MBEK (For KV series amplifier)

MBEK011BCV	100 W Single phase 100 V to 120 V	37
MBEK011BCVC	100 W Single phase 100 V to 120 V (Power cable included)*	37
MBEK015BCV	100 W Single/3-Phase 200 V to 240 V	37
MBEK015BCVC	100 W Single/3-Phase 200 V to 240 V (Power cable included)*	37
MBEK021BCV	200 W Single phase 100 V to 120 V	39
MBEK025BCV	200 W Single/3-Phase 200 V to 240 V	39
MBEK043BCV	400 W 3-Phase 200 V to 240 V	41
MBEK083BCV	750 W 3-Phase 200 V to 240 V	43
MBEK5A1BCV	50 W Single phase 100 V to 120 V	35
MBEK5A1BCVC	50 W Single phase 100 V to 120 V (Power cable included)*	35
MBEK5A5BCV	50 W Single/3-Phase 200 V to 240 V	35
MBEK5A5BCVC	50 W Single/3-Phase 200 V to 240 V (Power cable included)*	35

* This part number is the ordering part number for the amplifier and power cable, not for ordering amplifier only.

MBMS (For KV series motor)

MBMS011BLA	60 mm sq. Round shaft motor 100 W Single phase 100 V to 120 V	Without oil seal	37
MBMS011BLC	60 mm sq. Round shaft motor 100 W Single phase 100 V to 120 V	With oil seal	37
MBMS011BLN	60 mm sq. D-cut shaft motor 100 W Single phase 100 V to 120 V	Without oil seal	37
MBMS011BLQ	60 mm sq. D-cut shaft motor 100 W Single phase 100 V to 120 V	With oil seal	37
MBMS011BLS	60 mm sq. Keyway, center tap shaft motor 100 W Single phase 100 V to 120 V	Without oil seal	37
MBMS011BLU	60 mm sq. Keyway, center tap shaft motor 100 W Single phase 100 V to 120 V	With oil seal	37
MBMS012BLA	60 mm sq. Round shaft motor 100 W Single/3-Phase 200 V to 240 V	Without oil seal	37
MBMS012BLC	60 mm sq. Round shaft motor 100 W Single/3-Phase 200 V to 240 V	With oil seal	37
MBMS012BLN	60 mm sq. D-cut shaft motor 100 W Single/3-Phase 200 V to 240 V	Without oil seal	37
MBMS012BLQ	60 mm sq. D-cut shaft motor 100 W Single/3-Phase 200 V to 240 V	With oil seal	37
MBMS012BLS	60 mm sq. Keyway, center tap shaft motor 100 W Single/3-Phase 200 V to 240 V	Without oil seal	37
MBMS012BLU	60 mm sq. Keyway, center tap shaft motor 100 W Single/3-Phase 200 V to 240 V	With oil seal	37
MBMS021BLA	60 mm sq. Round shaft motor 200 W Single phase 100 V to 120 V	Without oil seal	39
MBMS021BLC	60 mm sq. Round shaft motor 200 W Single phase 100 V to 120 V	With oil seal	39
MBMS021BLN	60 mm sq. D-cut shaft motor 200 W Single phase 100 V to 120 V	Without oil seal	39
MBMS021BLQ	60 mm sq. D-cut shaft motor 200 W Single phase 100 V to 120 V	With oil seal	39
MBMS021BLS	60 mm sq. Keyway, center tap shaft motor 200 W Single phase 100 V to 120 V	Without oil seal	39
MBMS021BLU	60 mm sq. Keyway, center tap shaft motor 200 W Single phase 100 V to 120 V	With oil seal	39
MBMS022BLA	60 mm sq. Round shaft motor 200 W Single/3-Phase 200 V to 240 V	Without oil seal	39
MBMS022BLC	60 mm sq. Round shaft motor 200 W Single/3-Phase 200 V to 240 V	With oil seal	39
MBMS022BLN	60 mm sq. D-cut shaft motor 200 W Single/3-Phase 200 V to 240 V	Without oil seal	39
MBMS022BLQ	60 mm sq. D-cut shaft motor 200 W Single/3-Phase 200 V to 240 V	With oil seal	39
MBMS022BLS	60 mm sq. Keyway, center tap shaft motor 200 W Single/3-Phase 200 V to 240 V	Without oil seal	39
MBMS022BLU	60 mm sq. Keyway, center tap shaft motor 200 W Single/3-Phase 200 V to 240 V	With oil seal	39
MBMS042BLA	60 mm sq. Round shaft motor 400 W 3-Phase 200 V to 240 V	Without oil seal	41
MBMS042BLC	60 mm sq. Round shaft motor 400 W 3-Phase 200 V to 240 V	With oil seal	41
MBMS042BLN	60 mm sq. D-cut shaft motor 400 W 3-Phase 200 V to 240 V	Without oil seal	41

Model No.	Specifications	Page
-----------	----------------	------

MBMS (For KV series motor)

MBMS042BLQ	60 mm sq. D-cut shaft motor 400 W 3-Phase 200 V to 240 V	With oil seal	41
MBMS042BLS	60 mm sq. Keyway, center tap shaft motor 400 W 3-Phase 200 V to 240 V	Without oil seal	41
MBMS042BLU	60 mm sq. Keyway, center tap shaft motor 400 W 3-Phase 200 V to 240 V	With oil seal	41
MBMS082BLA	80 mm sq. Round shaft motor 750 W 3-Phase 200 V to 240 V	Without oil seal	43
MBMS082BLC	80 mm sq. Round shaft motor 750 W 3-Phase 200 V to 240 V	With oil seal	43
MBMS082BLN	80 mm sq. D-cut shaft motor 750 W 3-Phase 200 V to 240 V	Without oil seal	43
MBMS082BLQ	80 mm sq. D-cut shaft motor 750 W 3-Phase 200 V to 240 V	With oil seal	43
MBMS082BLS	80 mm sq. Keyway, center tap shaft motor 750 W 3-Phase 200 V to 240 V	Without oil seal	43
MBMS082BLU	80 mm sq. Keyway, center tap shaft motor 750 W 3-Phase 200 V to 240 V	With oil seal	43
MBMS5AZBLA	38 mm sq. Round shaft motor 50 W Single phase 100 V to 120 V, Single/3-Phase 200 V to 240 V	Without oil seal	35
MBMS5AZBLC	38 mm sq. Round shaft motor 50 W Single phase 100 V to 120 V, Single/3-Phase 200 V to 240 V	With oil seal	35
MBMS5AZBLN	38 mm sq. D-cut shaft motor 50 W Single phase 100 V to 120 V, Single/3-Phase 200 V to 240 V	Without oil seal	35
MBMS5AZBLQ	38 mm sq. D-cut shaft motor 50 W Single phase 100 V to 120 V, Single/3-Phase 200 V to 240 V	With oil seal	35
MBMS5AZBLS	38 mm sq. Keyway, center tap shaft motor 50 W Single phase 100 V to 120 V, Single/3-Phase 200 V to 240 V	Without oil seal	35
MBMS5AZBLU	38 mm sq. Keyway, center tap shaft motor 50 W Single phase 100 V to 120 V, Single/3-Phase 200 V to 240 V	With oil seal	35

MBMU (For GP series motor)

MBMU1E1AB	90 mm sq. Pinion shaft motor 130 W Single phase 100 V to 120 V	61
MBMU1E2AB	90 mm sq. Pinion shaft motor 130 W Single/3-Phase 200 V to 240 V	61
MBMU5AZAB	80 mm sq. Pinion shaft motor 50 W Single phase 100 V to 120 V, Single/3-Phase 200 V to 240 V	57
MBMU9A1AB	90 mm sq. Pinion shaft motor 90 W Single phase 100 V to 120 V	59
MBMU9A2AB	90 mm sq. Pinion shaft motor 90 W Single/3-Phase 200 V to 240 V	59

MBMU (For GV series motor)

MBMU1E1AZ	90 mm sq. Pinion shaft motor 130 W Single phase 100 V to 120 V	21
MBMU1E2AZ	90 mm sq. Pinion shaft motor 130 W Single/3-Phase 200 V to 240 V	21
MBMU1E1AS	90 mm sq. Round shaft motor 130 W Single phase 100 V to 120 V	21
MBMU1E2AS	90 mm sq. Round shaft motor 130 W Single/3-Phase 200 V to 240 V	21
MBMU5AZAX	80 mm sq. Pinion shaft motor 50 W Single phase 100 V to 120 V, Single/3-Phase 200 V to 240 V	17
MBMU5AZAS	80 mm sq. Round shaft motor 50 W Single phase 100 V to 120 V, Single/3-Phase 200 V to 240 V	17
MBMU9A1AZ	90 mm sq. Pinion shaft motor 90 W Single phase 100 V to 120 V	19
MBMU9A2AZ	90 mm sq. Pinion shaft motor 90 W Single/3-Phase 200 V to 240 V	19
MBMU9A1AS	90 mm sq. Round shaft motor 90 W Single phase 100 V to 120 V	19
MBMU9A2AS	90 mm sq. Round shaft motor 90 W Single/3-Phase 200 V to 240 V	19

Index

Model No.	Specifications	Page
MX8G (For GV series gear head)		
MX8G100B	80 mm sq. Reduction ratio: 1/100	17,23
MX8G10B	80 mm sq. Reduction ratio: 1/10	17,23
MX8G12.5B	80 mm sq. Reduction ratio: 1/12.5	17,23
MX8G120B	80 mm sq. Reduction ratio: 1/120	17,23
MX8G150B	80 mm sq. Reduction ratio: 1/150	17,23
MX8G15B	80 mm sq. Reduction ratio: 1/15	17,23
MX8G180B	80 mm sq. Reduction ratio: 1/180	17,23
MX8G18B	80 mm sq. Reduction ratio: 1/18	17,23
MX8G20B	80 mm sq. Reduction ratio: 1/20	17,23
MX8G25B	80 mm sq. Reduction ratio: 1/25	17,23
MX8G3.6B	80 mm sq. Reduction ratio: 1/3.6	17,23
MX8G30B	80 mm sq. Reduction ratio: 1/30	17,23
MX8G36B	80 mm sq. Reduction ratio: 1/36	17,23
MX8G3B	80 mm sq. Reduction ratio: 1/3	17,23
MX8G50B	80 mm sq. Reduction ratio: 1/50	17,23
MX8G5B	80 mm sq. Reduction ratio: 1/5	17,23
MX8G60B	80 mm sq. Reduction ratio: 1/60	17,23
MX8G6B	80 mm sq. Reduction ratio: 1/6	17,23
MX8G7.5B	80 mm sq. Reduction ratio: 1/7.5	17,23
MX8G75B	80 mm sq. Reduction ratio: 1/75	17,23
MX8G90B	80 mm sq. Reduction ratio: 1/90	17,23
MX8G9B	80 mm sq. Reduction ratio: 1/9	17,23

Model No.	Specifications	Page
MY9G (For GV series gear head)		
MY9G100B	90 mm sq. Hinge attached Reduction ratio: 1/100	19,21,23
MY9G10B	90 mm sq. Hinge attached Reduction ratio: 1/10	19,21,23
MY9G12.5B	90 mm sq. Hinge attached Reduction ratio: 1/12.5	19,21,23
MY9G120B	90 mm sq. Hinge attached Reduction ratio: 1/120	19,21,23
MY9G150B	90 mm sq. Hinge attached Reduction ratio: 1/150	19,21,23
MY9G15B	90 mm sq. Hinge attached Reduction ratio: 1/15	19,21,23
MY9G180B	90 mm sq. Hinge attached Reduction ratio: 1/180	19,21,23
MY9G18B	90 mm sq. Hinge attached Reduction ratio: 1/18	19,21,23
MY9G200B	90 mm sq. Hinge attached Reduction ratio: 1/200	19,21,23
MY9G20B	90 mm sq. Hinge attached Reduction ratio: 1/20	19,21,23
MY9G25B	90 mm sq. Hinge attached Reduction ratio: 1/25	19,21,23
MY9G3.6B	90 mm sq. Hinge attached Reduction ratio: 1/3.6	19,21,23
MY9G30B	90 mm sq. Hinge attached Reduction ratio: 1/30	19,21,23
MY9G36B	90 mm sq. Hinge attached Reduction ratio: 1/36	19,21,23
MY9G3B	90 mm sq. Hinge attached Reduction ratio: 1/3	19,21,23
MY9G50B	90 mm sq. Hinge attached Reduction ratio: 1/50	19,21,23
MY9G5B	90 mm sq. Hinge attached Reduction ratio: 1/5	19,21,23
MY9G60B	90 mm sq. Hinge attached Reduction ratio: 1/60	19,21,23
MY9G6B	90 mm sq. Hinge attached Reduction ratio: 1/6	19,21,23
MY9G7.5B	90 mm sq. Hinge attached Reduction ratio: 1/7.5	19,21,23

Model No.	Specifications	Page
MY9G (For GV series gear head)		
MY9G75B	90 mm sq. Hinge attached Reduction ratio: 1/75	19,21,23
MY9G90B	90 mm sq. Hinge attached Reduction ratio: 1/90	19,21,23
MY9G9B	90 mm sq. Hinge attached Reduction ratio: 1/9	19,21,23

Model No.	Specifications	Page
MZ9G (For GV series gear head)		
MZ9G100B	90 mm sq. Hinge not attached Reduction ratio: 1/100	19,21,23
MZ9G10B	90 mm sq. Hinge not attached Reduction ratio: 1/10	19,21,23
MZ9G12.5B	90 mm sq. Hinge not attached Reduction ratio: 1/12.5	19,21,23
MZ9G120B	90 mm sq. Hinge not attached Reduction ratio: 1/120	19,21,23
MZ9G150B	90 mm sq. Hinge not attached Reduction ratio: 1/150	19,21,23
MZ9G15B	90 mm sq. Hinge not attached Reduction ratio: 1/15	19,21,23
MZ9G180B	90 mm sq. Hinge not attached Reduction ratio: 1/180	19,21,23
MZ9G18B	90 mm sq. Hinge not attached Reduction ratio: 1/18	19,21,23
MZ9G200B	90 mm sq. Hinge not attached Reduction ratio: 1/200	19,21,23
MZ9G20B	90 mm sq. Hinge not attached Reduction ratio: 1/20	19,21,23
MZ9G25B	90 mm sq. Hinge not attached Reduction ratio: 1/25	19,21,23
MZ9G3.6B	90 mm sq. Hinge not attached Reduction ratio: 1/3.6	19,21,23
MZ9G30B	90 mm sq. Hinge not attached Reduction ratio: 1/30	19,21,23
MZ9G36B	90 mm sq. Hinge not attached Reduction ratio: 1/36	19,21,23
MZ9G3B	90 mm sq. Hinge not attached Reduction ratio: 1/3	19,21,23
MZ9G50B	90 mm sq. Hinge not attached Reduction ratio: 1/50	19,21,23
MZ9G5B	90 mm sq. Hinge not attached Reduction ratio: 1/5	19,21,23
MZ9G60B	90 mm sq. Hinge not attached Reduction ratio: 1/60	19,21,23
MZ9G6B	90 mm sq. Hinge not attached Reduction ratio: 1/6	19,21,23
MZ9G7.5B	90 mm sq. Hinge not attached Reduction ratio: 1/7.5	19,21,23
MZ9G75B	90 mm sq. Hinge not attached Reduction ratio: 1/75	19,21,23
MZ9G90B	90 mm sq. Hinge not attached Reduction ratio: 1/90	19,21,23
MZ9G9B	90 mm sq. Hinge not attached Reduction ratio: 1/9	19,21,23

MEMO

GV series

KV series

GP series

Options

Information

Sales office

[Panasonic sales office of motors]

(January 2013)

Country	Company Name	City	Address	TEL
				FAX
North America	Panasonic Industrial Devices Sales Company of America (PIDSA)	New Jersey	Three Panasonic Way, 7E-2 Secaucus, NJ 07094 U.S.A.	+1-201-348-5356
				+1-201-392-4315
	Panasonic Electric Works Corporation of America (PEWA)	New Jersey	629 Central Avenue New Providence, NJ 07974 U.S.A.	+1-908-464-3550
				Technical Support: +1-877-624-7872 +1-908-771-5655
Brazil	Panasonic Electric Works Corporation of America Brazil Rep. Office	Sao Paulo	Rua Cubatao, 320- 8 andar-Paraiso, CEP 04013-001 Sao Paulo-SP	+55-11-3889-4006
				+55-11-3889-4103
Spain	Panasonic Electric Works Espana S.A.	Madrid	Barajas Park, San Severo 20, 28042 Madrid, Spain	+34-91-329-3875
				+34-91-329-2976
Germany	Panasonic Industrial Devices Sales Europe GmbH	Munich	Hans-Pinsel-Strasse 2 • D - 85540 Haar • Germany	+49-89-46-159-0
				+49-89-46-159-212
Italy	Panasonic Electric Works Italia srl	Verona	Via del Commercio 3-5 (Z.I.Ferlina), 37012 Bussolengo (VR), Italy	+39-045-6752711
				+39-045-6700444
Russia	Electroprivod Ltd. (*Distributors)	St.Petersburg	Russia, 194044, St.Peterburg, 29A, Viborgskay emb. Website: http://www.electroprivod.ru	+7-703-09-81
				+7-493-27-26
China	Panasonic Shun Hing Industrial Devices Sales (Hong Kong) Co.,Ltd. (PSIDSHK)	Hong kong	Level 33, Office Tower, Langham Place, 8 Argyle Street, Mongkok, Kin.,Hong Kong	+852-2529-7322
				+852-2598-9743
	Panasonic Industrial Devices Sales (China) Co.,Ltd. (PIDSCN)	Shanghai	Floor 7, China Insurance Building, 166 East Road LuJiaZui PuDong New District, Shanghai, China	+86-21-3855-2442
				+86-21-3855-2375
Panasonic SH Industrial Devices Sales (Shenzhen) Co.,Ltd. (PSIDSSZN)	Shenzhen	8/F, Tower Three, Kerry Plaza, 1-1 Zhongxinsi Road, Futian District, Shenzhen, China	+86-755-8255-8551	
			+86-755-8255-8668	
India	Panasonic Industrial Devices Sales India (PIDSIN) (A division company of Panasonic India Pvt Ltd.)	Haryana	7th Floor, ABW Tower, IFFCO Chowk, MG Road, Sector 25, Gurgaon-122 001, Haryana, India	+91-124-4596600
				+91-124-4596625
Korea	Panasonic Industrial Devices Sales Korea Co., Ltd. (PIDSKR)	Seoul	14F, West-gate Bldg, 332 Migeundong, Seodaemun-gu, Seoul, 120-020, Korea	+82-2-795-9600
				+82-2-795-1542
Taiwan	Panasonic Industrial Devices Sales Taiwan Co.,Ltd.	Taipei	12F, No.9, SongGao Rd., Taipei 110, Taiwan, R.O.C.	+886-2-2757-1900
				+886-2-2757-1977
Singapore	Panasonic Industrial Devices Sales Asia Pte. Ltd.	Singapore	300 Beach Road #16-01 The Concourse Singapore 199555	+65-6390-3718
				+65-6390-3801
	Intermech Machinery Pte Ltd. (*Distributors)	Singapore	2 Woodlands Sector 1 #03-25, Woodlands Spectrum 1 Singapore 738068 Website: http://www.intermech.com.sg	+65-6751-5088
				+65-6759-2122

Country	Company Name	City	Address	TEL
				FAX
Malaysia	Panasonic Industrial Devices Sales Asia Pte. Ltd.	Singapore	300 Beach Road #16-01 The Concourse Singapore 199555	+65-6390-3718
				+65-6390-3801
	Panamech Machinery Sdn Bhd (*Distributors)	Kuala Lumpur	No.14, Lorong Sanggul 1C, Bandar Puteri, 41200 Klang, Selangor Darul Ehsan	+60-3-5161-7876
				+60-3-5161-7136
	Website: http://www.panamech.com.my			
	Panamech (PG) Sdn Bhd (*Distributors)	Penang	Sri Relau Komplex, Unit 1-3-11, Persiaran Bukit Jambul 1, 11900 Penang	+60-4-643-8266
+60-4-645-1639				
Website: http://www.panamech.com.my				
Thailand	Panasonic Industrial Devices Sales Asia Pte. Ltd.	Singapore	300 Beach Road #16-01 The Concourse Singapore 199555	+65-6390-3718
				+65-6390-3801
	Premier Automation Center Co.,Ltd. (*Distributors)	Bangkok	73 Soi Ladkrabang 30 Ladkrabang Bangkok 10520	+66-2181-2299
				+66-2181-2288
	Website: http://www.premier-ac.co.th			
	Plenty Island (Thai) Co.,Ltd. (*Distributors)	Bangkok	3 Soi Charoenrat 10, Charoenrat Road., Bangkhlo, Bangkoklaem, Bangkok 10120	+66-2291-9933
				+66-2291-2065
	Website: http://www.plenty.co.th			
Seng Charoen Muang Co.,Ltd. (*Distributors)	Bangkok	12/349 Moo 15, Bangkaew, Bangplee, Samutprakam 10540	+66-2397-9577	
			+66-2361-8207	
Website: http://www.sengscm.com				
Indonesia	Panasonic Industrial Devices Sales Asia Pte. Ltd.	Singapore	300 Beach Road #16-01 The Concourse Singapore 199555	+65-6390-3718
				+65-6390-3801
	PT. Handal Yesindo Sejahtera (*Distributors)	Surabaya	Jl. Raya Kutisari 8A, Surabaya, Indonesia	+62-31-843-8844
				+62-31-841-4333
	Website: http://www.handalyesindo.com			
	PT.Riasarana Electrindo (*Distributors)	Jakarta	Jl. Prof. Dr. Latumenten Grogol Permai blok D No. 8-15 Jakarta 11460, Indonesia	+62-21-564-9178
+62-21-566-7405				
Website: http://www.risacorps.com				

GV series

KV series

GP series

Options

Information