

# Shift chain<sup>®</sup>

SLIDING-ES TYPE : Enclosed Skid

- ST044ES - 123p
- ST072ES - 128p
- ST095ES - 133p
- ST120ES - 138p



Min ●●●●●● Max

## Shift chain® ST 044ES Enclosed Skid Type

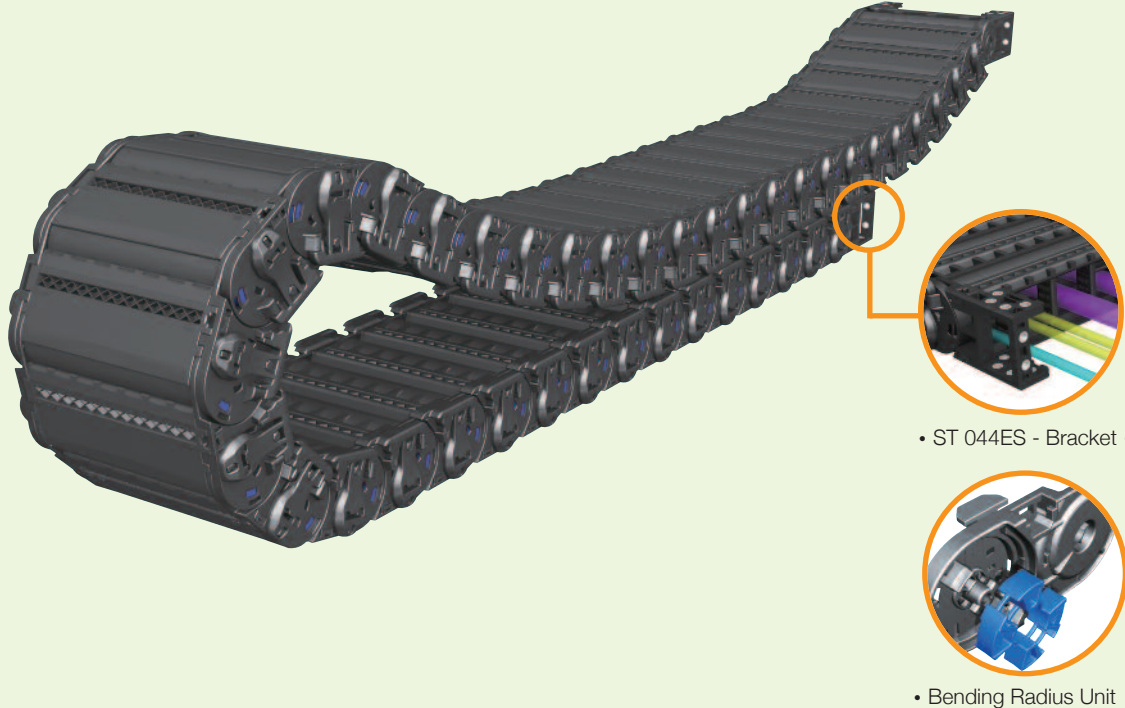

• ST 044ES - Bracket •

• Bending Radius Unit •

### MATERIAL

- **Chain material:**  
CPS-polyamide with glass fiber reinforced UL94-HB
- **Low Noise & Low Mote:**  
Skid사용으로 소음 감소
- **Temperature :** -30°C ~ +130°C
- **Coefficient of Friction :**  
0.3 ~ 0.4 μ

### Applications

- Facilities and equipments requiring a long travel distance as below; Gantry Robots, Robot Carriages, Automatic Welding Lines, Gantry Cranes, Gantry loader, etc.

Gantry robots, Robot carriages, Automatic welding Gantry crane, Gantry loader 등  
설치 장비의 케이블이 장거리 이동을 요구하는 사업장에  
케이블 보호가 필요할 때 적용.

Shift Chain ES-Type can be found on car manufacturer's welding line, where excess material can damage your inserted cables.

산업 현장, 외부 위험 요소로부터 케이블의 보호가 필요한 용접 라인, 도장 라인 등에 적용,  
외부 위험 요소로부터 케이블의 보호가 요구되는 케이블 체인의 적용 사업장에 사용 가능.

### Calculation of the chain length

$$\left[ L = \frac{L_s}{2} + L_p \right]$$

After enclosed frame of sliding type, it can protect cable perfectly from outside, substance for long distance application.

Sliding 방식의 밀폐형 프레임 적용하여 설비의 장거리구 동시에도 외부 이물질로부터 Cable을 완벽하게 보호하도록 설계됨.



## Enclosed Skid Type **ST 044ES**

### LAYOUT OF THE CHAIN

Ls: Stroke Lp: Loop Length Lf: Loop Projection

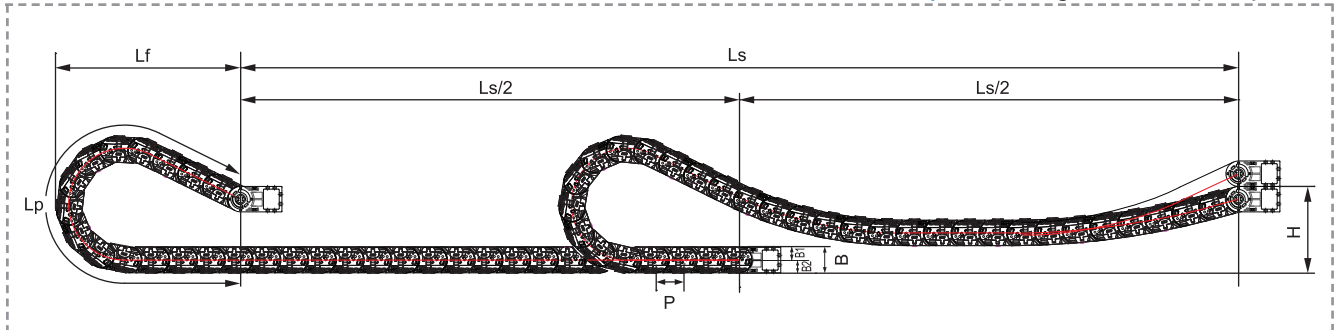

(Dimensions in mm)

Bending radius R	70	90	120	150
Lp	544	662	926	1,190
L f	249	289	393	497
H	130	130	130	130

### ST 044ES Type

Pitch P: 44mm

Height B: 38.5mm

B1: 19.5mm

B2: 19mm

### ORDERING (주문방법)

## ST 044ES. 100. R120 / F - 1500L : 10ST

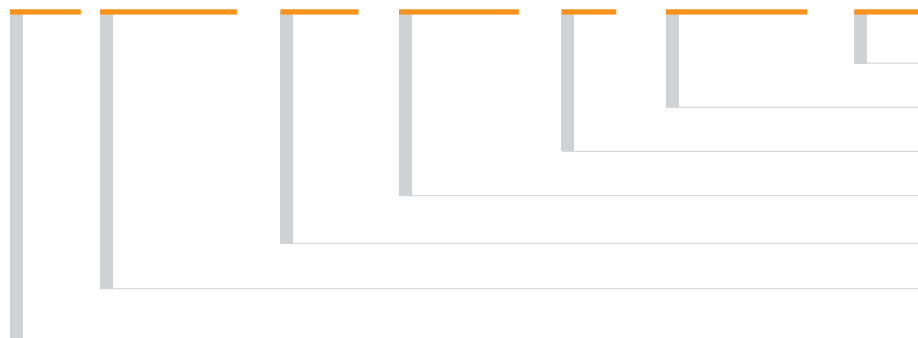

- 주문수량 Q'ty(set)
  - 체인길이 Length(mm)
  - 브라켓 Free End Bracket
  - 곡률반경 Bending Radius
  - 내폭 Inside Width
  - 장거리타입(ES) Skid Type
- Shift Chain**

### BRACKET TYPE (브라켓타입)

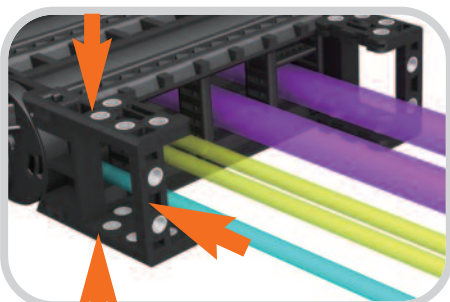

### FEB (Free End Bracket)

FEB Fixes the cable chain to the machinery or moving application. CPS has improved mounting efficiency by unifying the existing Easy End Bracket and Normal End Bracket.

The End Bracket is designed to move up and down as the cable chain or application requires.

체인을 고정하는 끝부분으로 기존 Easy End Bracket과 Normal End Bracket을 하나로 통합한 방식으로 취부의 효율성을 높임.

장거리 이동용 ST ES-Type에 적용되는 Free End Bracket은 곡률반경을 자유롭게 형성하여 브라켓 부위의 파손을 방지.

- ▶ BR should not be inserted in the joint of side band and Free End Bracket. FEB와 결합하는 Side Band에는 BR을 삽입하지 않음.

- ▶ Above products are patent registered item which can be protected by industrial property right. (상기제품은 특허등록 제품으로 산업재산권의 보호를 받는 제품입니다.)

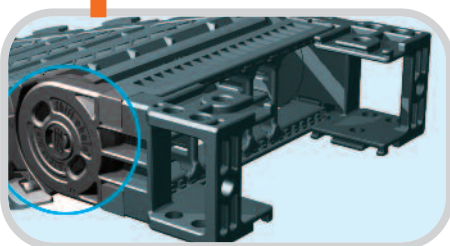

## Enclosed Skid Type **ST 044ES**

### CHAIN CROSS SECTION

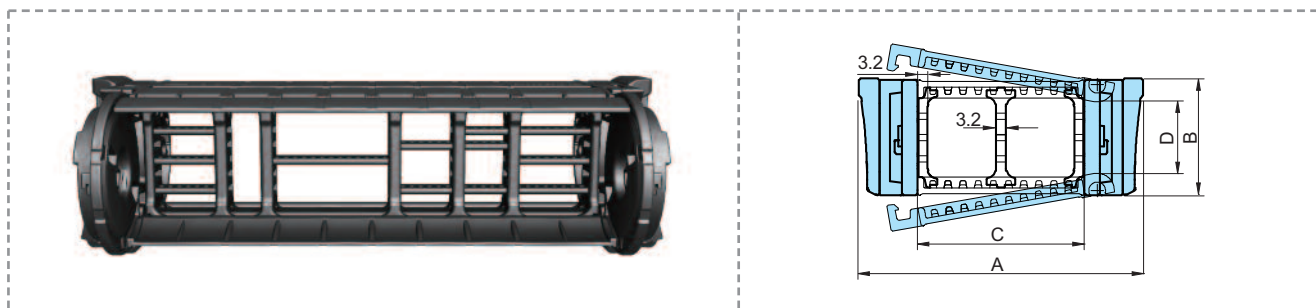

Chain Type	A	B	C	D	Bending Radius(R)	Weight in kg/m
ST 044ES.035	74		35			
ST 044ES.050	89		50			
ST 044ES.055	94		55			
ST 044ES.075	114		75			
ST 044ES.100	139	38.5	100	26	70, 90, 120, 150	-
ST 044ES.125	164		125			
ST 044ES.150	189		150			
ST 044ES.175	214		175			
ST 044ES.200	239		200			

### FREE END BRACKET

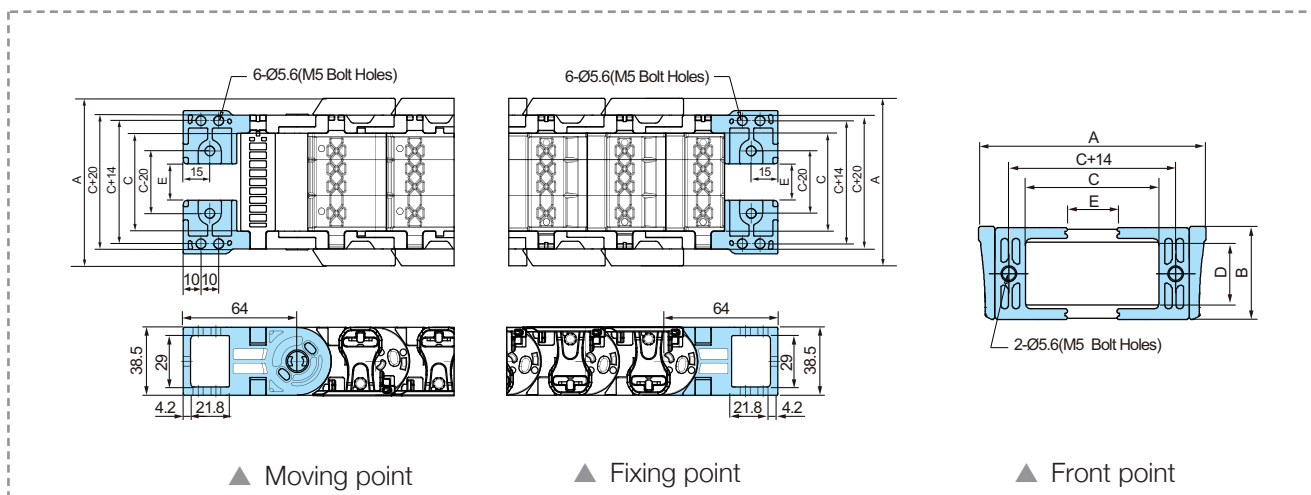

Chain Type	A	B	C	D	E	Hole Type
ST 044ES.035	74		35		0.4	
ST 044ES.050	89		50		15.4	
ST 044ES.055	94		55		20.4	
ST 044ES.075	114		75		40.4	
ST 044ES.100	139	38.5	100	26	65.4	M5 Bolt Holes
ST 044ES.125	164		125		90.4	
ST 044ES.150	189		150		115.4	
ST 044ES.175	214		175		140.4	
ST 044ES.200	239		200		165.4	



## Enclosed Skid Type **ST 044ES**

### DIVIDERS & SEPARATORS

Dividers (Vertical) and Separators (Horizontal) divide the inner chamber of the cable chain to give each cable diameter its own center and keep the cables separated from each other. The use of a separator in some cases, can also reduce the width requirements as two or more levels can be made within the same chamber. To prevent twisting or damage to the cables, as a rule, there needs to be at least 10% space between the inserted cable and its enclosure.

디바이더(세로분리대)와 세퍼레이터(가로분리대)는 체인내에 많은 케이블들이 입선될 시 케이블을 서로 분리하여 케이블상호간 마찰로 인한 **피복손상 및 단선을 방지하는 역할**을 하며 케이블과 10%이상의 여유공간을 확보해야 합니다.

또한 케이블을 체인내 2단이상 입선시 반드시 세퍼레이터를 디바이더에 결합하여 사용해야 케이블의 꼬임방지와 피복손상을 방지할 수 있습니다.

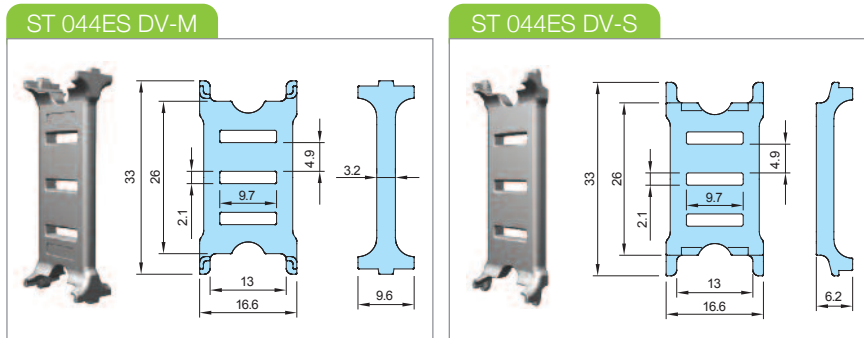

▶ Assemble divider every Two links. / 2링크마다 결합

### ST044ES Separators (SP) (No. : S-SP/M)

Chain Type \ Separators	SP035	SP050	SP055	SP075	SP100	SP125	SP150	SP175	SP200
ST 044ES	○	○	○	○	○	○	○	○	○

### TIE WRAP

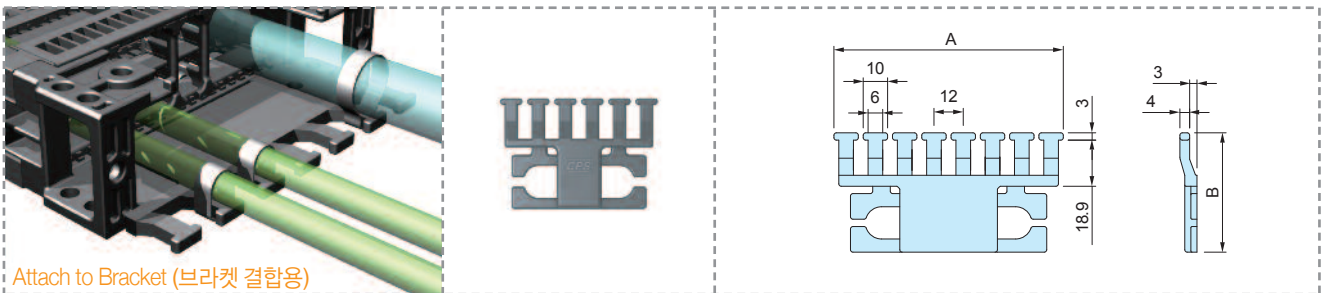

Attach to Bracket (브라켓 결합용)

(Dimensions in mm)

Tie Wrap	035	050	055	075	100	125
A	46	69.4	70	94	118	142
B	35.4	48.9	48.9	48.9	48.9	48.9

The Tie Wrap separated from the Shift Chain bracket, when installed properly, protects the inserted cables from becoming entangled and twisted during operation.

There are two types in the tie wrap; Attached & Unattached to the bracket.

Tie Wrap은 Shift Chain의 브라켓을 기준으로 설치함으로써 체인의 움직임으로 인해 체인내의 케이블이나 호스가 당겨져 단선되는 경우를 방지할 수 있다. Shift Chain의 Tie Wrap은 브라켓부분과 근접해서 사용할 수 있는 사양과 브라켓에 결합해서 사용할 수 있는 사양으로 구분되어 사용할 수 있다.



## Enclosed Skid Type **ST 044ES**

### GUIDE CHANNEL

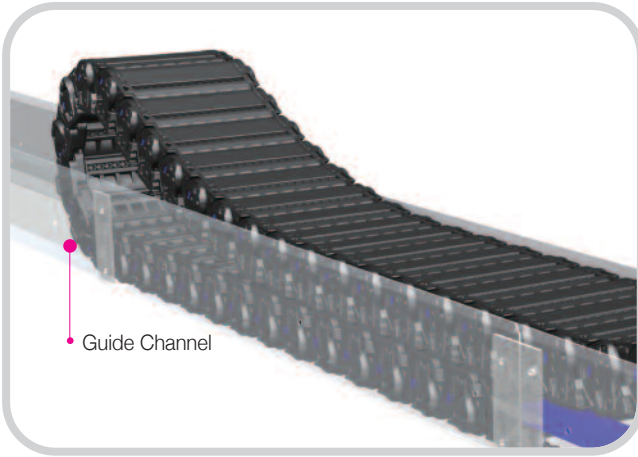

For long stroke applications the guide channel is applied to ensure that the Shift Chain Sliding Chain stays on track and to ensure safety during operation. With the application of a rubber pad on the channel floor, noise is reduced to a minimum. Guide Channels are made of Steel + Zn and can be customized with SUS material .

Steel Guide Channel은 장거리 이동형 ST044S Type 전용으로 Chain의 이탈을 방지하는 가이드 역할을 하며 Chain이동 시 소음을 줄이기 위해 Guide Channel 바닥면에 고무패드를 사용함으로써 소음을 일정 부분 억제 시키는 역할을 합니다. Guide Channel의 재질은 스틸 + 아연도금으로 제작되며 SUS재질로 주문 제작 가능합니다.

▶Thickness can be changed by the product standards of material. ( 두께는 원재료의 생산 규격에 따라 달라질 수 있습니다. )

### ST 044ES Type

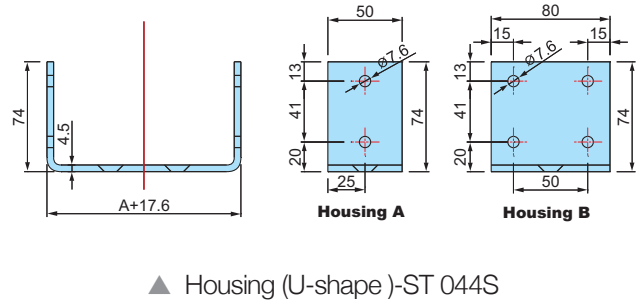
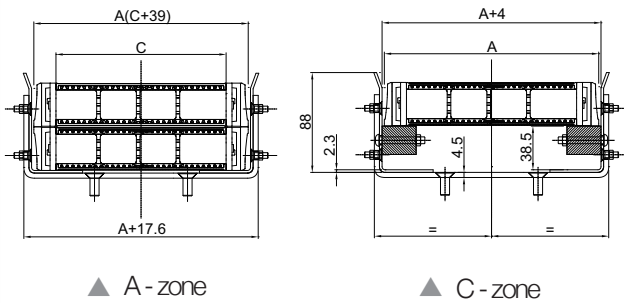

### ST 044ES Side Panel

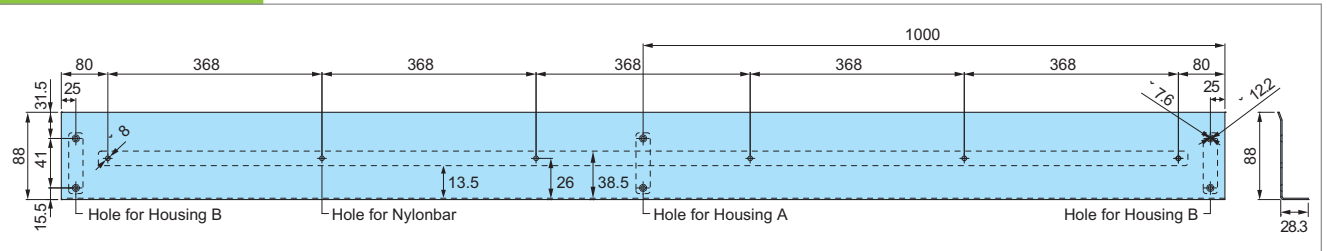

### ORDERING (주문방법)

## ST-GCS 044ES. 100 / A, B, C : 200M



길이	Length(mm)
사이드패널 종류	Panel A, B, C-Zone
내폭	Inside Width
체인종류	Chain Type
Steel Guide Channel	
Shift Chain	



Min ●●●●●● Max

## Shift chain<sup>®</sup> ST 072ES Enclosed Skid Type

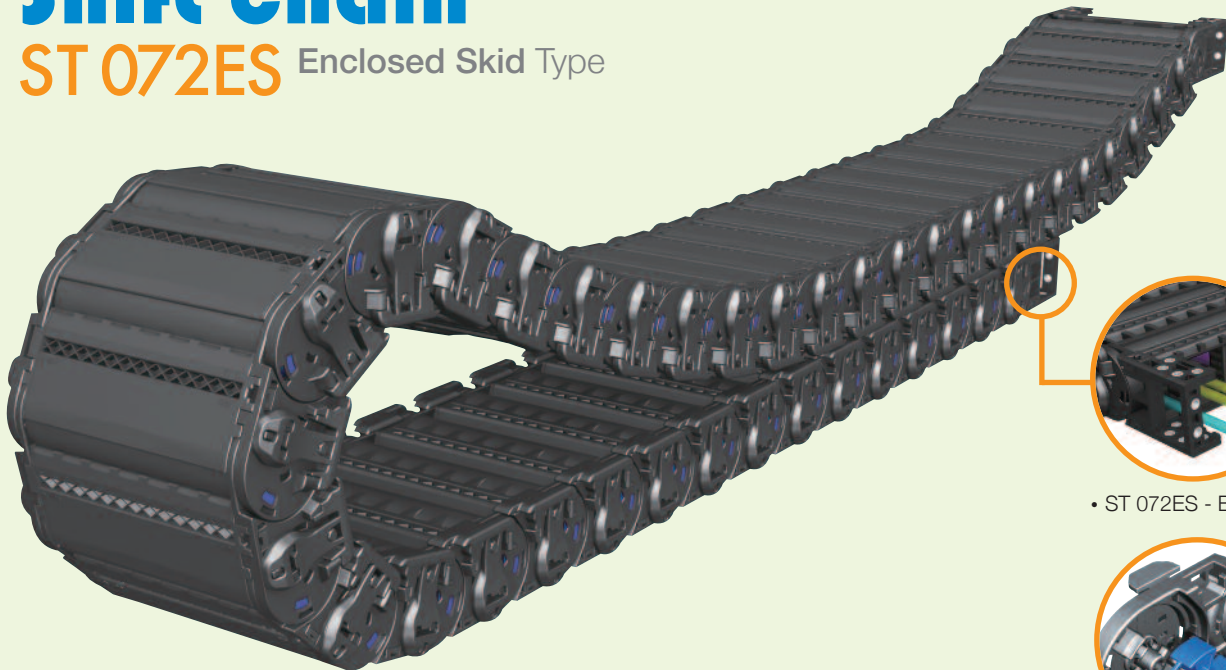

• ST 072ES - Bracket •



• Bending Radius Unit •

### MATERIAL

- **Chain material:**  
CPS-polyamide with glass fiber reinforced UL94-HB
- **Low Noise & Low Mote:**  
Skid 사용으로 소음 감소
- **Temperature :** -30°C ~ +130°C
- **Coefficient of Friction :**  
0.3 ~ 0.4 μ
- **Applications**

Facilities and equipments requiring a long travel distance as below; Gantry Robots, Robot Carriages, Automatic Welding Lines, Gantry Cranes, Gantry loader, etc.

Gantry robots, Robot carriages, Automatic welding Gantry crane, Gantry loader.. 등 설치 장비의 케이블이 장거리 이동을 요구하는 사업장에 케이블 보호가 필요할 때 적용.

Shift Chain ES-Type can be found on car manufacturer's welding line, where excess material can damage your inserted cables. 산업 현장, 외부 위험 요소로부터 케이블의 보호가 필요한 용접 라인, 도장 라인 등에 적용, 외부 위험 요소로부터 케이블의 보호가 요구되는 케이블 체인의 적용 사업장에 사용 가능.

### Calculation of the chain length

$$\left[ L = \frac{Ls}{2} + Lp \right]$$

After enclosed frame of sliding type, it can protect cable perfectly from outside, substance for long distance application.

Sliding 방식의 밀폐형 프레임을 적용하여 설비의 장거리구 동시에도 외부 이물질로부터 Cable을 완벽하게 보호하도록 설계됨.



## Enclosed Skid Type **ST 072ES**

### LAYOUT OF THE CHAIN

LS: Stroke   Lp: Loop Length   Lf: Loop Projection

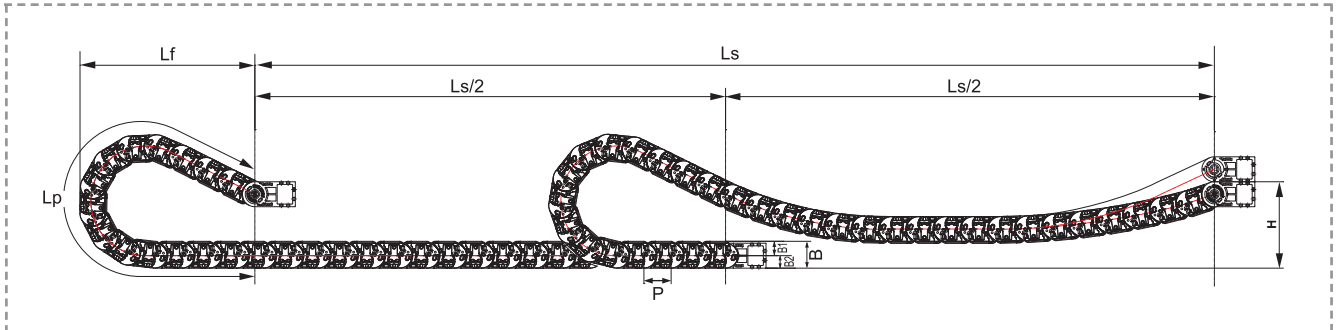

(Dimensions in mm)

Bending radius R	120	145	200	250	300
Lp	917	1,063	1,400	1,840	2,280
L f	420	470	580	752	924
H	230	230	230	230	230

### ST 072ES Type

**Pitch P:** 72mm  
**Height B:** 71mm  
**B1:** 38mm  
**B2:** 33mm

### ORDERING (주문방법)

## ST 072ES.150.R200 / F-10000L:10ST

주문수량	Q'ty(set)
체인길이	Length(mm)
브라켓	Free End Bracket
곡률반경	Bending Radius
내폭	Inside Width
장거리타입(ES)	Enclosed Skid Type
<b>Shift Chain</b>	

### BRACKET TYPE (브라켓타입)

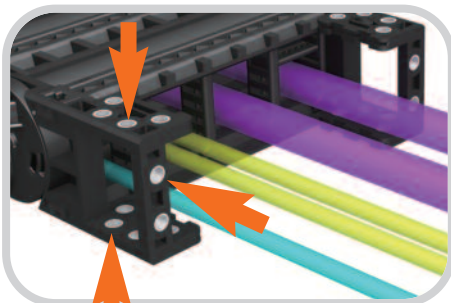

### FEB (Free End Bracket)

FEB Fixes the cable chain to the machinery or moving application. CPS has improved mounting efficiency by unifying the existing Easy End Bracket and Normal End Bracket.

The End Bracket is designed to move up and down as the cable chain or application requires. To add strength, steel washers are inserted into the fixing holes of each Free End Bracket.

체인을 고정하는 끝부분으로 기존 Easy End Bracket과 Normal End Bracket을 하나로 통합한 방식으로 취부의 효율성을 높임.

장거리 이동용 ST ES-Type에 적용되는 Free End Bracket은 곡률반경을 자유롭게 형성하여 브라켓 부위의 파손을 방지하며 또한 스틸와셔를 결합하여 더욱 견고한 취부가 가능.

- ▶ BR should not be inserted in the joint of side band and Free End Bracket  
FEB와 결합하는 Side Band에는 BR을 삽입하지 않음.
- ▶ Normal Frame, not FRU/FRD, is inserted into M.FEB.  
M.FEB에는 밀폐형 Frame(FRU/FRD)이 아닌 일반형 Frame이 삽입됨.

▶ Above products are patent registered item which can be protected by industrial property right. (상기 제품은 특허등록 제품으로 산업재산권의 보호를 받는 제품입니다.)

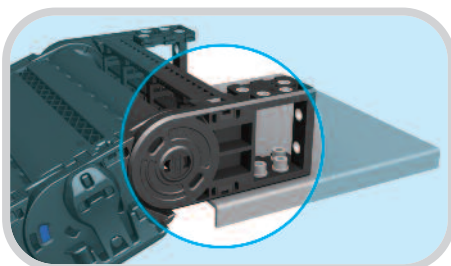





## Enclosed Skid Type **ST 072ES**

### CHAIN CROSS SECTION



Chain Type	A	B	C	D	Bending Radius(R)	Weight in kg/m
ST 072ES.050	105		50			2.77
ST 072ES.075	130		75			3.01
ST 072ES.100	155	71.8	100	44	120,145, 200, 250, 300	3.25
ST 072ES.125	180		125			3.49
ST 072ES.150	205		150			3.73

▲ 특수 프레임 적용 가능. (C:140,165,190,240)

▲ Application of special frame. (C:140,165,190,240)

### FREE END BRACKET

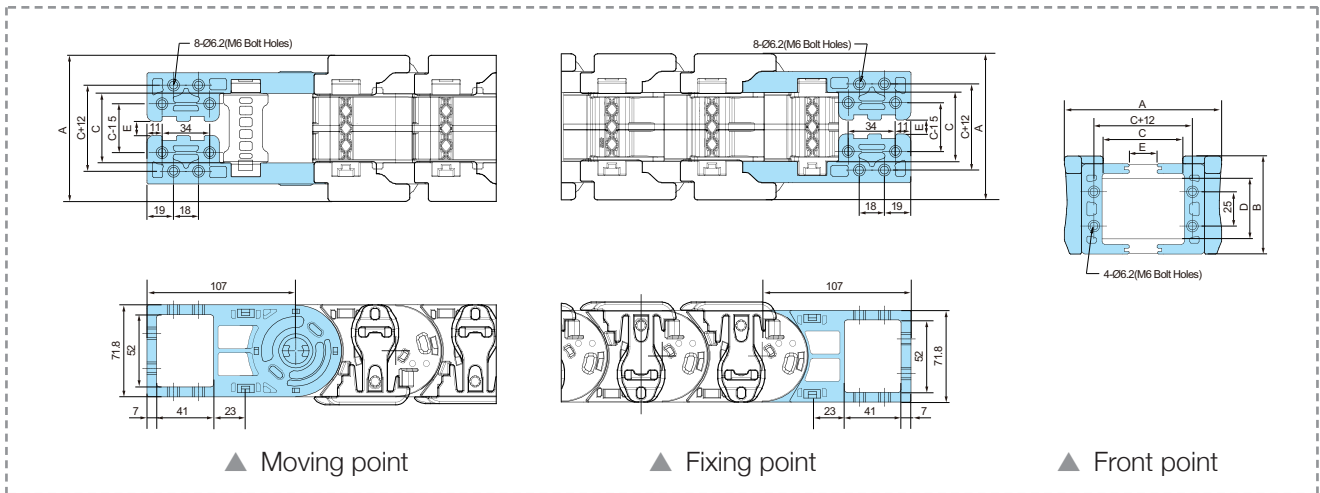

▲ Moving point

▲ Fixing point

▲ Front point

Chain Type	A	B	C	D	E	Hole Type
ST 072ES.050	105		50		10	M6 Bolt Holes
ST 072ES.075	130		75		35	
ST 072ES.100	155	71.8	100	44	60	
ST 072ES.125	180		125		85	
ST 072ES.150	205		150		110	

▲ 특수 프레임 적용 가능. (C:140,165,190,240)

▲ Application of special frame. (C:140,165,190,240)

## Enclosed Skid Type **ST 072ES**

CP5 CABLE CHAIN

SHIFT CHAIN

SABIN CHAIN

REVOLVING CHAIN

HELIX CHAIN

ROBO-KIT

CP5FLEX

CP5FIX

### **DIVIDERS**

Dividers (Vertical) and Separators (Horizontal) divide the inner chamber of the cable chain to give each cable diameter its own center and keep the cables separated from each other. The use of separator in some cases, can also reduce the width requirements as two or more levels can be made within the same chamber. To prevent twisting or damage to the cables, as a rule, there needs to be at least 10% space between the inserted cable and its enclosure.

디바이더(세로분리대)와 세퍼레이터(가로분리대)는 체인내에 많은 케이블들이 입선될 시 케이블들을 서로 분리하여 케이블상호간의 마찰로 인한 **피복손상 및 단선을 방지하는 역할**을 하며 케이블과 10%이상의 여유공간을 확보해야합니다.

또한 케이블을 체인내 2단이상 입선시 반드시 세퍼레이터를 디바이더에 결합하여 사용해야 케이블의 꼬임방지와 피복손상을 방지할 수 있습니다.

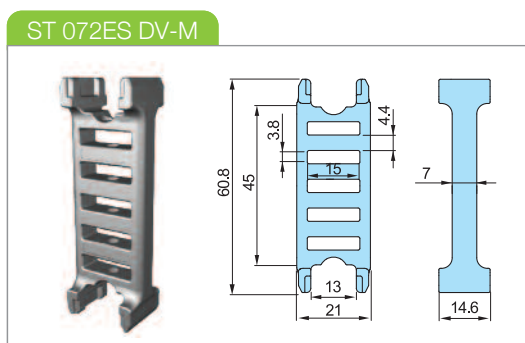
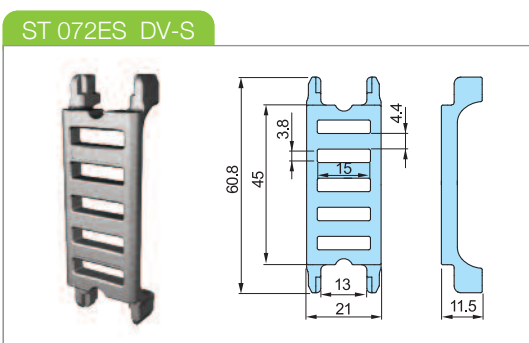

\*Assemble divider every Two links. / 2링크마다 결합

### **SEPARATORS (SP)**

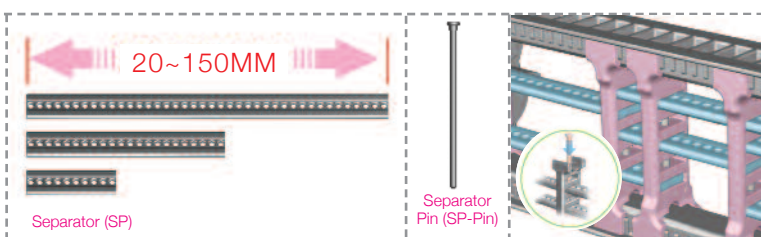

Separator is available in length from 20mm to 150mm and can be cut every 5mm for use. The combined use of divider and separator with the pin creates the most effective cable pattern and keep insertion space for cables safely, so it protects the inserted cables.

세퍼레이터의 사용길이는 최소20mm부터 최대150mm까지 사용가능하며 **5mm간격으로 절단**하여 원하는 길이로 사용가능합니다. 크기가 각각 다른 케이블을 크기에 맞게끔 공간분할이 용이하고 **세퍼레이터 핀으로 결합**하여 어떠한 경우에도 안전하게 케이블의 입선공간을 유지하여 케이블을 보호할 수 있습니다.

### **TIE WRAP**

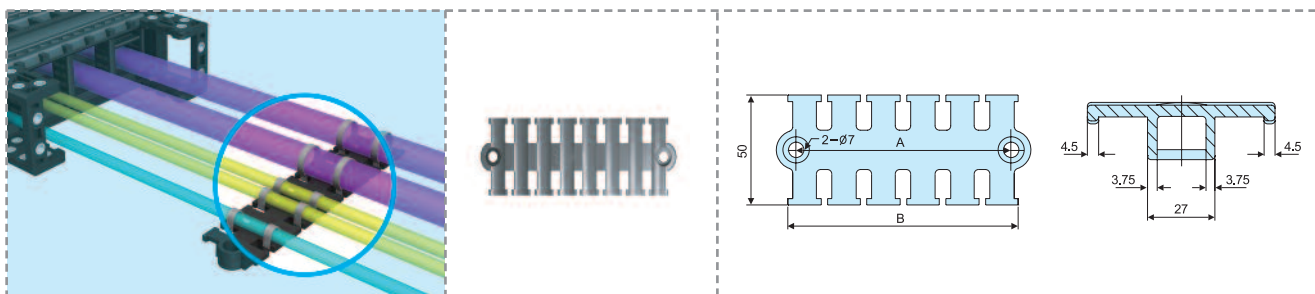

(Dimensions in mm)

Tie Wrap	050	075	100	125	150
A	58	75	98	122	141
B	65	82	105	129	148

The Tie Wrap separated from the Shift Chain bracket, when installed properly, protects the inserted cables from becoming entangled and twisted during operation.

Tie Wrap은 Shift Chain의 브라켓을 기준으로 바깥으로 설치함으로써 체인의 움직임으로 인한 **케이블의 유동을 방지**하고자 고정하는 시스템으로 케이블의 피복 손상 및 단선을 방지하는 역할을 합니다



## Enclosed Skid Type **ST 072ES**

### GUIDE CHANNEL

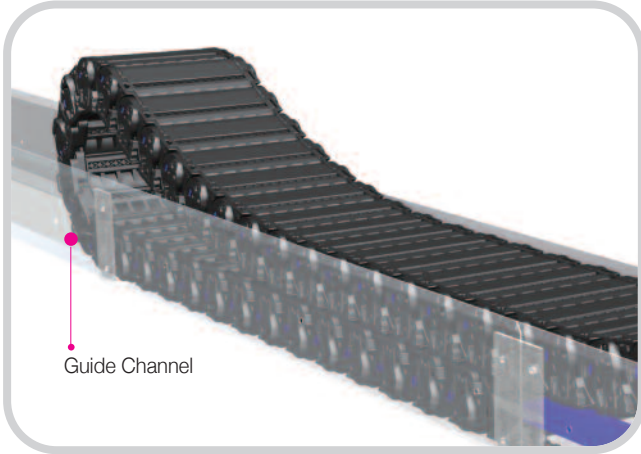

For long stroke applications the guide channel is applied to ensure that the Shift Chain Sliding Chain stays on track and to ensure safety during operation. With the application of a rubber pad on the channel floor, noise is reduced to a minimum. Guide Channels are made of Steel + Zn and can be customized with SUS material .

Steel Guide Channel은 장거리 이동형 ST 072ES Type 전용으로 Chain의 이탈을 방지하는 가이드 역할을 하며 Chain 이동시 소음을 줄이기 위해 Guide Channel 바닥면에 고무패드를 사용함으로써 소음을 일정부분 억제 시키는 역할을 합니다. Guide Channel의 재질은 스틸 + 아연도금으로 제작되며 SUS재질로 주 문제작 가능합니다.

▶ Thickness can be changed by the product standards of material.  
( 두께는 원재료의 생산규격에 따라 달라질 수 있습니다. )

### ST 072ES Type

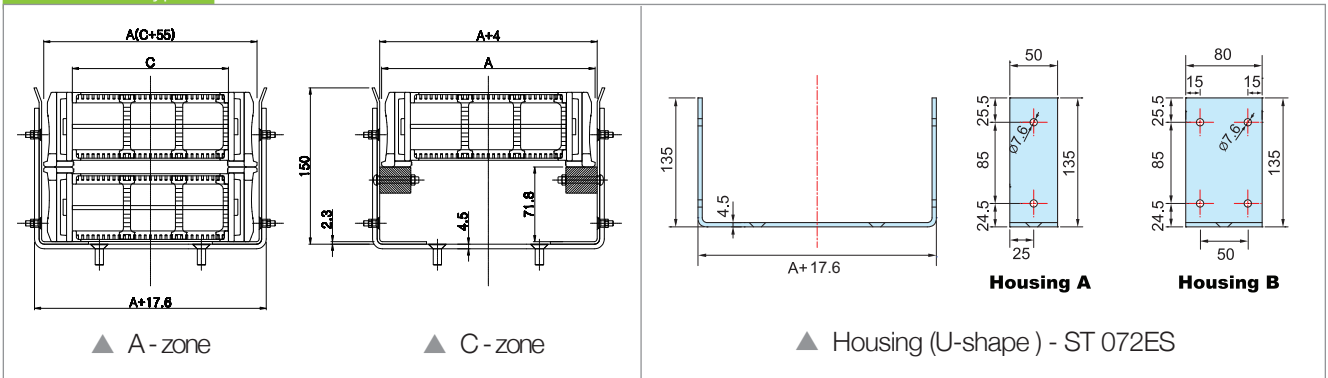

### ST 072ES Side Panel

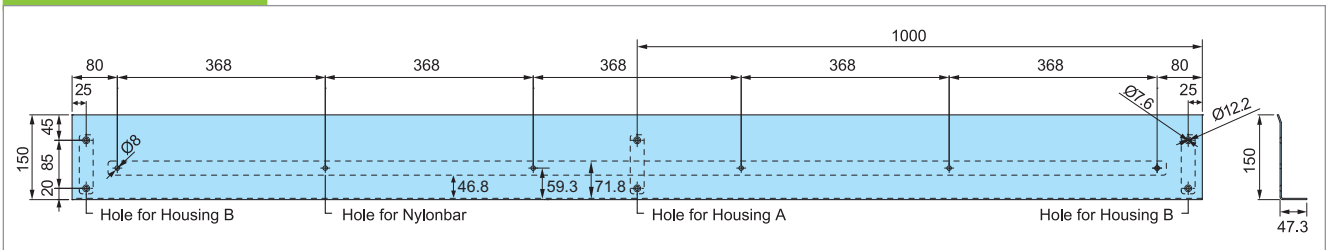

### ORDERING (주문방법)

## ST-GCS 072ES.150 / A, B, C : 200M

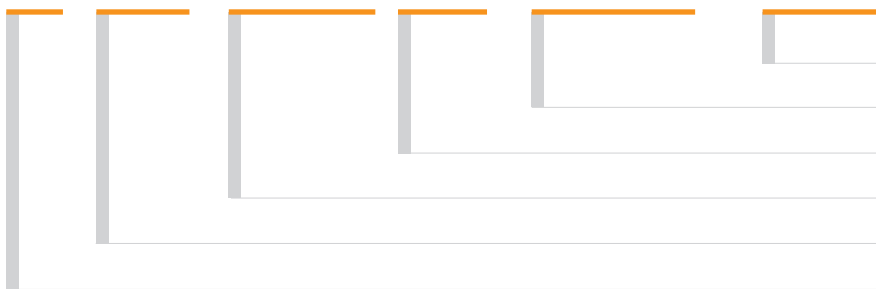

길이	Length(mm)
사이드판넬 종류	Panel A, B, C-Zone
내폭	Inside Width
체인종류	Chain Type
Steel Guide Channel	
Shift Chain	



Min ●●●●●● Max

## Shift chain® ST 095ES Enclosed Skid Type

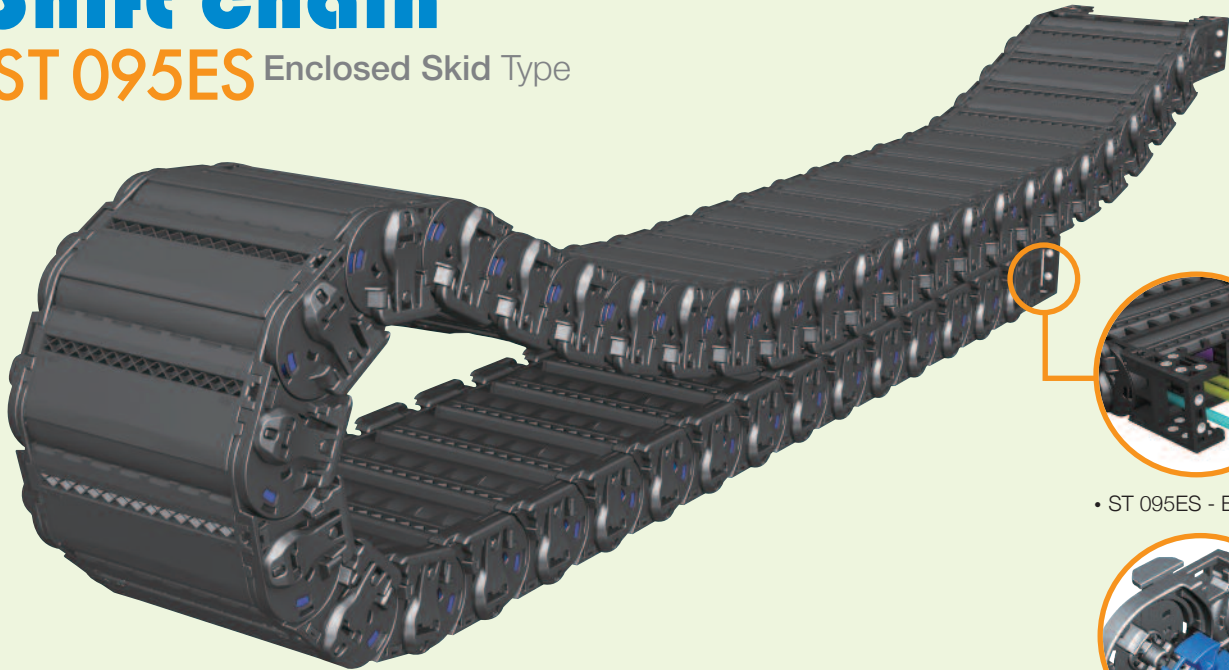

• ST 095ES - Bracket •

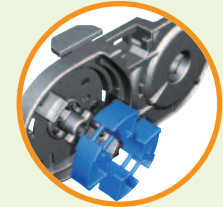

• Bending Radius Unit •

### MATERIAL

- **Chain material:**  
CPS-polyamide with glass fiber reinforced UL94-HB
- **Low Noise & Low Mote:**  
Skid 사용으로 소음 감소
- **Temperature :** -30°C ~ +130°C
- **Coefficient of Friction :**  
0.3 ~ 0.4 μ
- **Applications**

Facilities and equipments requiring a long travel distance as below; Gantry Robots, Robot Carriages, Automatic Welding Lines, Gantry Cranes, Gantry loader, etc.

Gantry robots, Robot carriages, Automatic welding Gantry crane, Gantry loader..등  
설치 장비의 케이블이 장거리 이동을 요구하는 사업장에 케이블 보호가 필요할 때 적용.

Shift Chain ES-Type can be found on car manufacturer's welding line, where excess material can damage your inserted cables.  
산업 현장, 외부 위험 요소로부터 케이블의 보호가 필요한 용접 라인, 도장 라인 등에 적용,  
외부위험 요소로부터 케이블의 보호가 요구되는 케이블 체인의 적용 사업장에 사용 가능.

### Calculation of the chain length

$$\left[ L = \frac{L_s}{2} + L_p \right]$$

Affer enclosed frame of sliding type, it can protect cable perfectly from outside, substance for long distance application.

Sliding 방식의 밀폐형 프레임을 적용하여 설비의 장거리구 동시에도 외부 이물질로부터 Cable을 완벽하게 보호하도록 설계됨.



## Enclosed Skid Type **ST 095ES**

### LAYOUT OF THE CHAIN

Ls: Stroke   Lp: Loop Length   Lf: Loop Projection

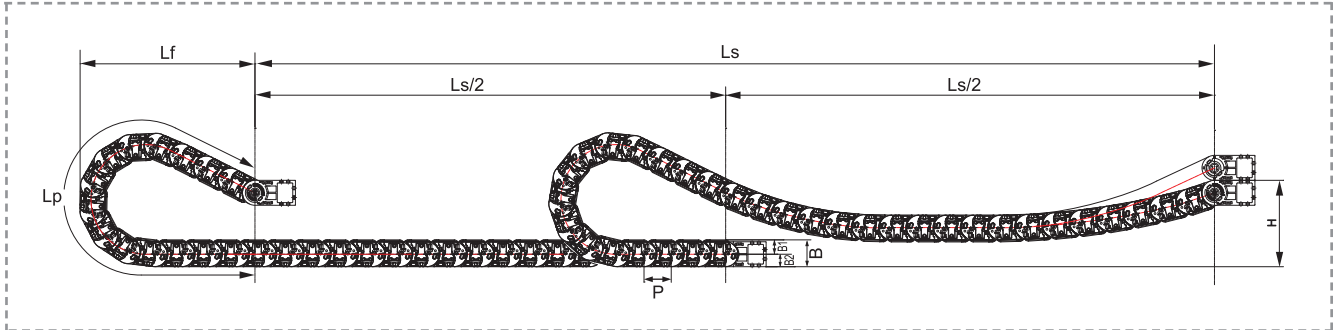

(Dimensions in mm)

Bending radius R	150	200	230	280	400
Lp	1,178	1,479	1,666	2,146	3,232
L f	534	634	694	889	1319
H	250	250	250	250	250

### ST 095ES Type

Pitch P: 95mm  
 Height B: 89mm  
 B1: 48mm  
 B2: 41mm

### ORDERING (주문방법)

## ST 095ES.200.R200 / F-10000L:10ST

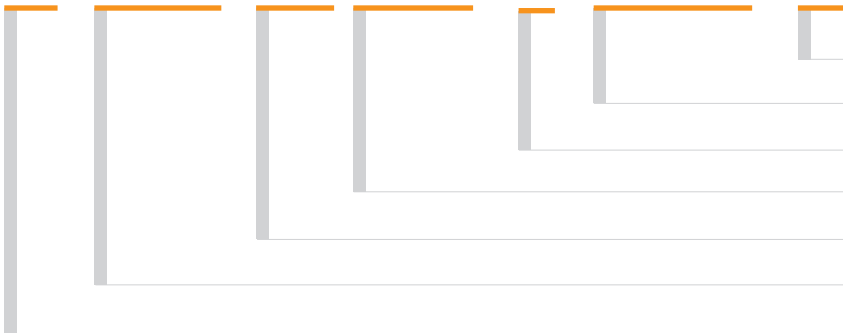

주문수량                    Q'ty(set)  
 체인길이                    Length(mm)  
 브라켓                      Free End Bracket  
 곡률반경                    Bending Radius  
 내폭                          Inside Width  
 장거리타입(ES)            Enclosed Skid Type  
**Shift Chain**

### BRACKET TYPE (브라켓타입)

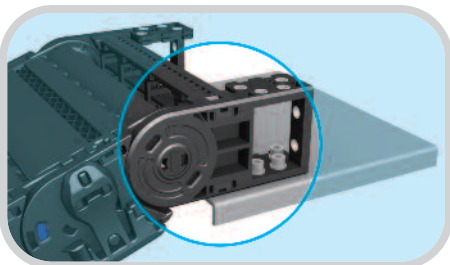
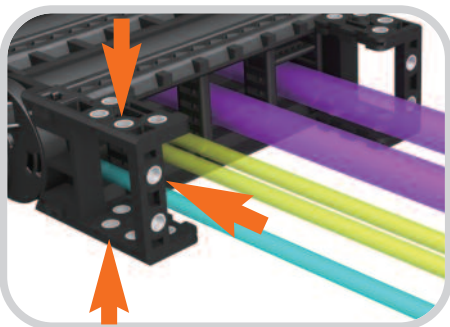

### FEB (Free End Bracket)

FEB Fixes the cable chain to the machinery or moving application. CPS has improved mounting efficiency by unifying the existing Easy End Bracket and Normal End Bracket.

The End Bracket is designed to move up and down as the cable chain or application requires. To add strength, steel washers are inserted into the fixing holes of each Free End Bracket.

체인을 고정하는 끝부분으로 기존 Easy End Bracket 과 Normal End Bracket을 하나로 통합한 방식으로 취부의 효율성을 높임.

장거리 이동용 ST ES-Type에 적용되는 Free End Bracket은 곡률반경을 자유롭게 형성하여 브라켓 부위의 파손을 방지하며 또한 스틸와셔를 결합하여 더욱 견고한 취부가 가능함.

- ▶ BR should not be inserted in the joint of side band and Free End Bracket FEB와 결합하는 Side Band에는 BR을 삽입하지 않음.
- ▶ Normal Frame, not FRU/FRD, is inserted into M.FEB. M.FEB에는 밀폐형 Frame(FRU/FRD)이 아닌 일반형 Frame이 삽입됨.
- ▶ Above products are patent registered item which can be protected by industrial property right. (상기제품은 특허등록 제품으로 산업재산권의 보호를 받는 제품입니다.)



## Enclosed Skid Type **ST 095ES**

### CHAIN CROSS SECTION



Chain Type	A	B	C	D	Bending Radius(R)	Weight in kg/m
ST 095ES.100	162		100		150, 200, 230, 280, 400	4.16
ST 095ES.125	187		125			4.41
ST 095ES.150	212	89	150	55		4.65
ST 095ES.175	237		175			4.90
ST 095ES.200	262		200			5.15

▲ 특수 프레임 적용 가능. (C:190,240)

▲ Application of special frame. (C:190,240)

### FREE END BRACKET

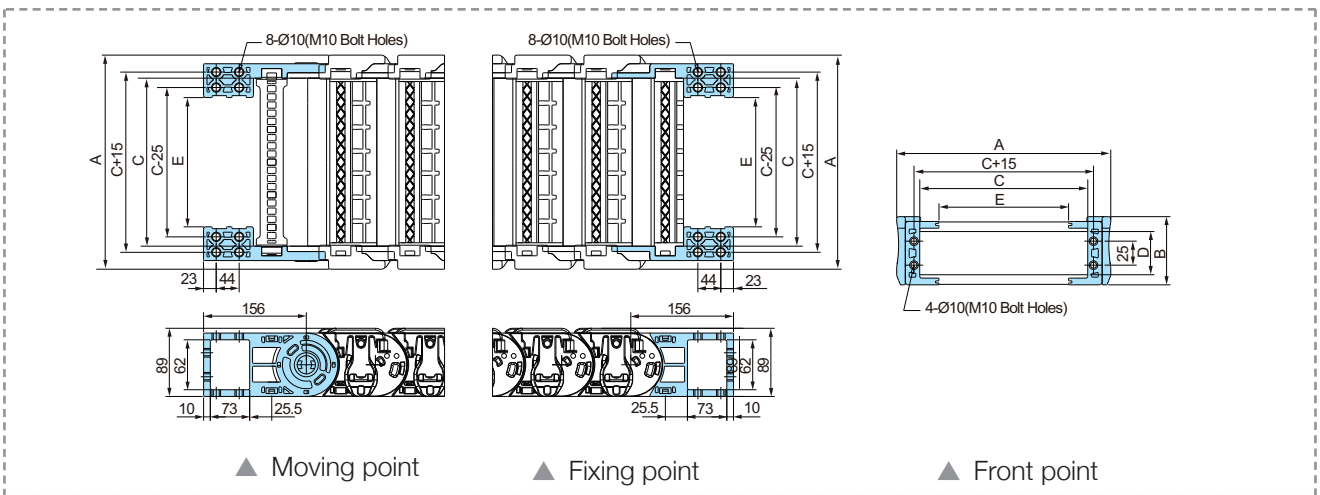

▲ Moving point

▲ Fixing point

▲ Front point

Chain Type	A	B	C	D	E	Hole Type
ST 095ES.100	162		100		49	M10 Bolt Holes
ST 095ES.125	187		125		74	
ST 095ES.150	212	89	150	55	99	
ST 095ES.175	237		175		124	
ST 095ES.200	262		200		149	

▲ 특수 프레임 적용 가능. (C:190,240)

▲ Application of special frame. (C:190,240)



## Enclosed Skid Type **ST 095ES**

### DIVIDERS

Dividers (Vertical) and Separators (Horizontal) divide the inner chamber of the cable chain to give each cable diameter its own center and keep the cables separated from each other. The use of separator in some cases, can also reduce the width requirements as two or more levels can be made within the same chamber. To prevent twisting or damage to the cables, as a rule, there needs to be at least 10% space between the inserted cable and its enclosure.

디바이더(세로 분리대)와 세퍼레이터(가로 분리대)는 체인 내에 많은 케이블들이 입선될 시 케이블들을 서로 분리하여 케이블상 호간의 마찰로 인한 **피복 손상 및 단선**을 방지하는 역할을 하며 케이블과 10%이상의 여유 공간을 확보해야 합니다.

또한 케이블을 체인 내 2단 이상 입선 시 반드시 세퍼레이터를 디바이더에 결합하여 사용해야 케이블의 꼬임 방지와 피복 손상을 방지할 수 있습니다.

ST 095ES DV-S

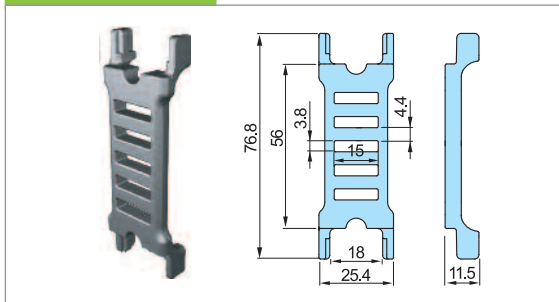

ST 095ES DV-M

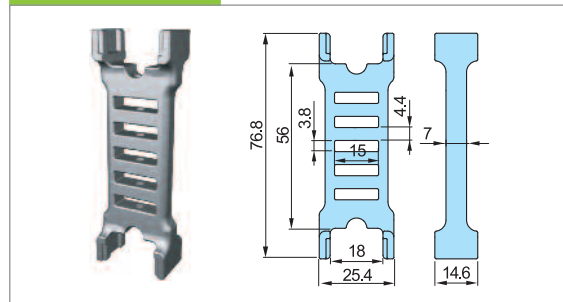

\*Assemble divider every Two links. / 2링크마다 결합

### SEPARATORS (SP)

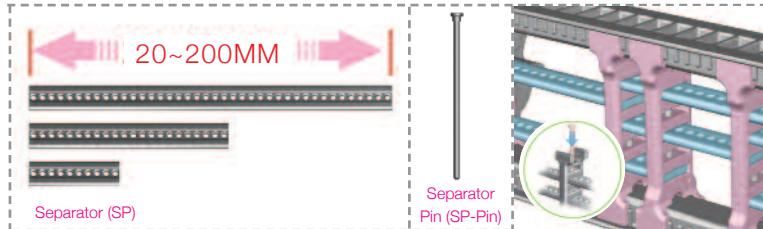

Separator is available in length from 20mm to 200mm and can be cut every 5mm for use. The combined use of divider and separator with the pin creates the most effective cable pattern and keep insertion space for cables safely, so it protects the inserted cables.

세퍼레이터의 사용길이는 최소20mm부터 최대200mm까지 사용가능하며 5mm간격으로 절단하여 원하는 길이로 사용가능합니다. 크기가 각각 다른 케이블을 크기에 맞게끔 공간분할이 용이하고 세퍼레이터 핀으로 결합하여 어떠한 경우에도 안전하게 케이블의 입선공간을 유지하여 안전하게 케이블을 보호할 수 있습니다.

### TIE WRAP

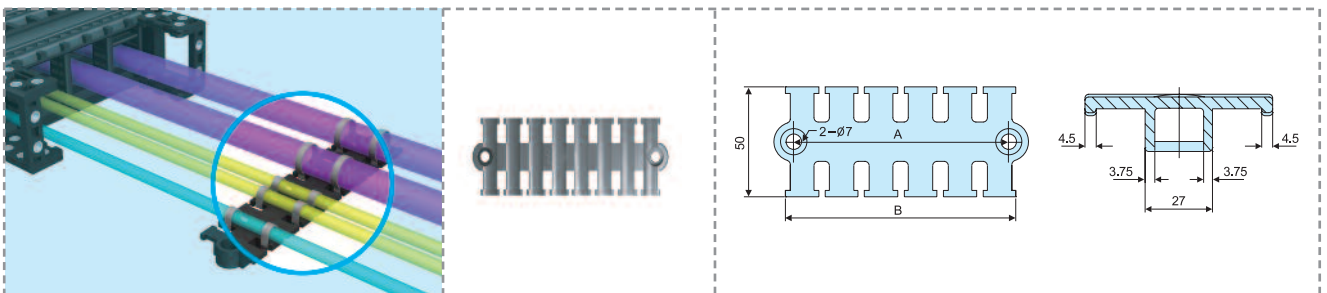

(Dimensions in mm)

Tie Wrap	050	075	100	125	150
A	58	75	98	122	141
B	65	82	105	129	148

The Tie Wrap separated from the Shift Chain bracket, when installed properly, protects the inserted cables from becoming entangled and twisted during operation

Tie Wrap은 Shift Chain의 브라켓을 기준으로 바깥으로 설치함으로써 체인의 움직임으로 인해 **케이블의 유동**을 방지하고자 고정하는 시스템으로 케이블의 피복손상 및 단선을 방지하는 역할을 합니다.



## Enclosed Skid Type **ST 095ES**

### GUIDE CHANNEL

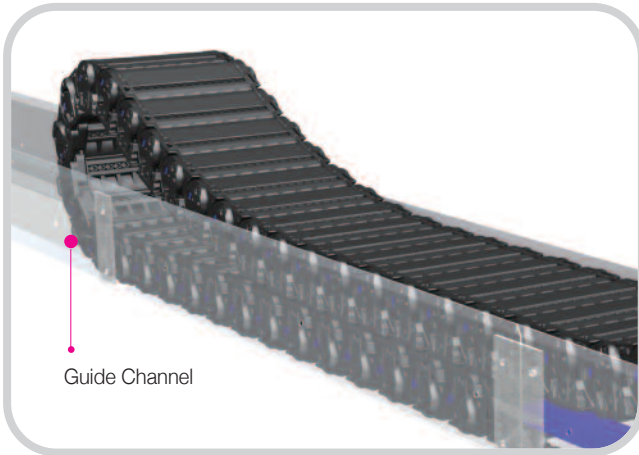

For long stroke applications the guide channel is applied to ensure that the Shift Chain Sliding Chain stays on track and to ensure safety during operation. With the application of a rubber pad on the channel floor, noise is reduced to a minimum. Guide Channels are made of Steel + Zn and can be customized with SUS material .

Steel Guide Channel은 장거리 이동형 ST 095ES Type 전용으로 Chain의 이탈을 방지하는 가이드 역할을 하며 Chain 이동시 소음을 줄이기 위 Guide Channel 바닥면에 고무패드를 사용함으로써 소음을 일정부분 억제 시키는 역할을 합니다. Guide Channel의 재질은 스틸 + 아연도금으로 제작되며 SUS 재질로 주 문제작 가능합니다.

▶ Thickness can be changed by the product standards of material.  
( 두께는 원재료의 생산규격에 따라 달라질 수 있습니다. )

### ST 095ES Type

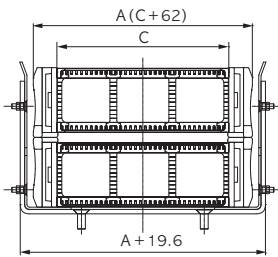

▲ A - zone

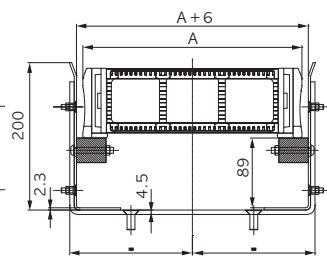

▲ C - zone

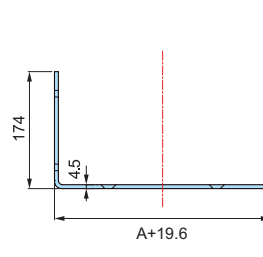

▲ Housing (U-shape) - ST 095ES

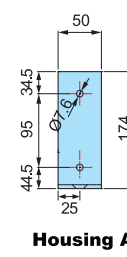

Housing A

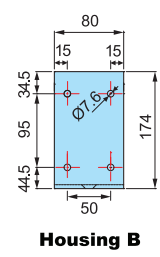

Housing B

### ST 095ES Side Panel

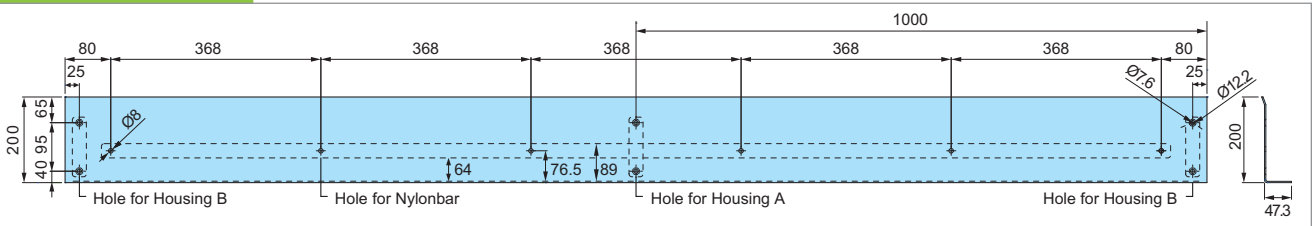

### ORDERING (주문방법)

## ST-GCS 095ES.175 / A, B, C : 200M



길이	Length(mm)
사이드판넬 종류	Panel A, B, C-Zone
내폭	Inside Width
체인종류	Chain Type
Steel Guide Channel	
<b>Shift Chain</b>	





## Shift chain<sup>®</sup> ST 120ES Enclosed Skid Type

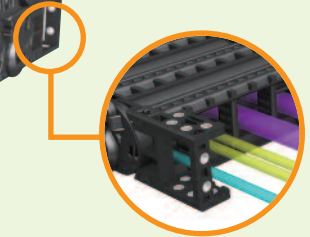
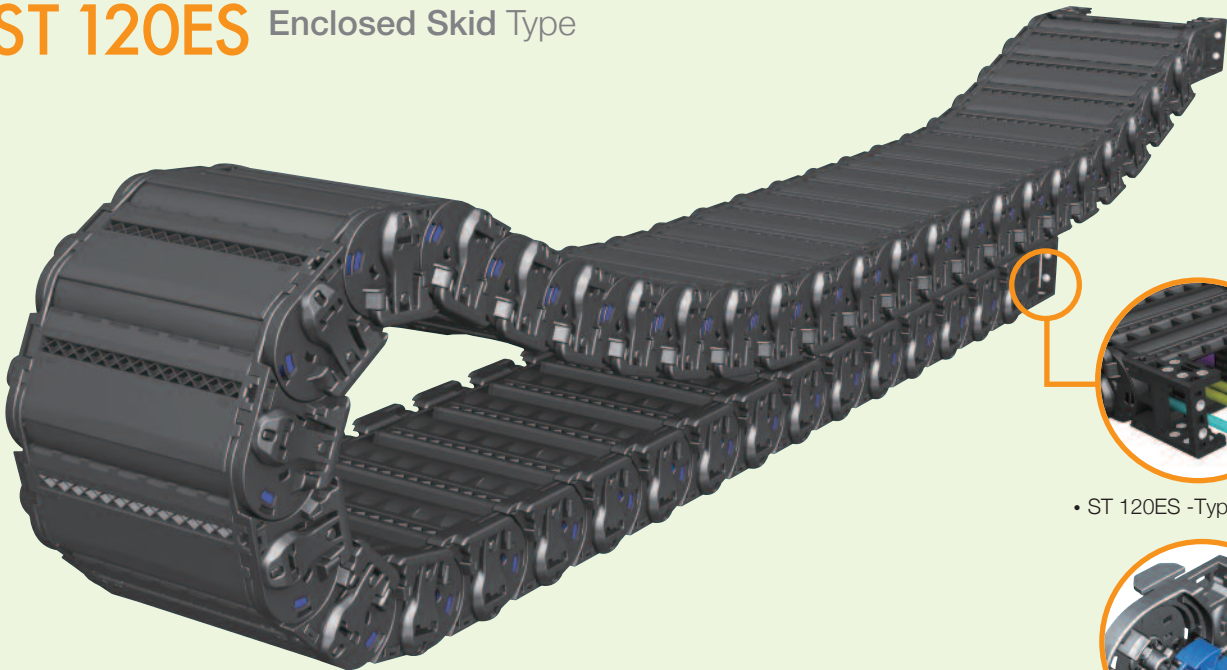

• ST 120ES -Type Bracket •

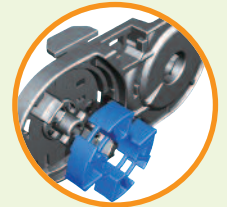

• Bending Radius Unit •

### MATERIAL

- **Chain material:**  
CPS-polyamide with glass fiber reinforced UL94-HB
- **Low Noise & Low Mote:**  
Skid 사용으로 소음 감소
- **Temperature :** -30°C ~ +130°C
- **Coefficient of Friction :**  
0.3 ~ 0.4 μ
- **Applications**

Facilities and equipments requiring a long travel distance as below; Gantry Robots, Robot Carriages, Automatic Welding Lines, Gantry Cranes, Gantry loader, etc.

Gantry robots, Robot carriages, Automatic welding Gantry crane, Gantry loader 등 설치 장비의 케이블이 장거리 이동을 요구하는 사업장에 케이블 보호가 필요할 때 적용.

Shift Chain ES-Type can be found on car manufacturer's welding line, where excess material can damage your inserted cables. 산업 현장, 외부 위험 요소로부터 케이블의 보호가 필요한 용접 라인, 도장 라인 등에 적용, 외부 위험 요소로부터 케이블의 보호가 요구되는 케이블 체인의 적용 사업장에 사용 가능.

### Calculation of the chain length

$$[ L = \frac{Ls}{2} + Lp ]$$

Affer enclosed frame of sliding type, it can protect cable perfectly from outside, substance for long distance application.

Sliding 방식의 밀폐형 프레임을 적용하여 설비의 장거리구 동시에도 외부 이물질로부터 Cable을 완벽하게 보호하도록 설계됨.



## Enclosed Skid Type **ST 120ES**

### LAYOUT OF THE CHAIN

Ls: Stroke Lp: Loop Length Lf: Loop Projection

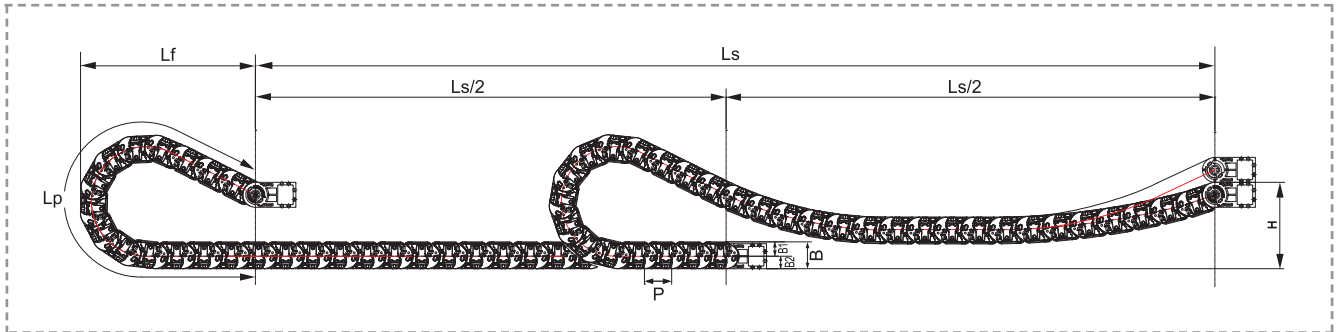

(Dimensions in mm)

Bending radius R	200	250	300	350	400	500
Lp	1,559	1,864	2,178	2,701	3,225	4,062
Lf	694	794	894	1,114	1,334	1,654
H	300	300	300	300	300	300

### ST 120ES Type

Pitch P: 120mm  
 Height B: 115mm  
 B1: 61mm  
 B2: 54mm

### ORDERING (주문방법)

## ST 120ES.300.R200 / F-10000L:10ST

주문수량	Q'ty(set)
체인길이	Length(mm)
브라켓	Free End Bracket
곡률반경	Bending Radius
내폭	Inside Width
장거리타입(ES)	Enclosed Skid Type
<b>Shift Chain</b>	

### BRACKET TYPE (브라켓타입)

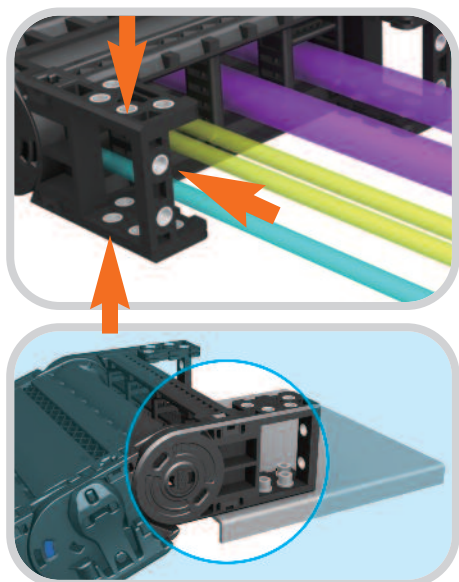

### FEB (Free End Bracket)

FEB Fixes the cable chain to the machinery or moving application. CPS has improved mounting efficiency by unifying the existing Easy End Bracket and Normal End Bracket.

The End Bracket is designed to move up and down as the cable chain or application requires. To add strength, steel washers are inserted into the fixing holes of each Free End Bracket.

체인을 고정하는 끝부분으로 기존 Easy End Bracket 과 Normal End Bracket을 하나로 통합한 방식으로 취부의 효율성을 높임.

장거리 이동용 ST ES-Type에 적용되는 Free End Bracket은 곡률반경을 자유롭게 형성하여 브라켓 부위의 파손을 방지하며 또한 스틸와셔를 결합하여 더욱 견고한 취부가 가능.

▶ BR should not be inserted in the joint of side band and Free End Bracket  
 FEB와 결합하는 Side Band에는 BR을 삽입하지 않음.

▶ Normal Frame, not FRU/FRD, is inserted into M.FEB.  
 M.FEB에는 밀폐형 Frame(FRU/FRD)이 아닌 일반형 Frame이 삽입됨.

▶ Above products are patent registered item which can be protected by industrial property right. (상기 제품은 특허등록 제품으로 산업재산권의 보호를 받는 제품입니다.)



## Enclosed Skid Type **ST 120ES**

### CHAIN CROSS SECTION

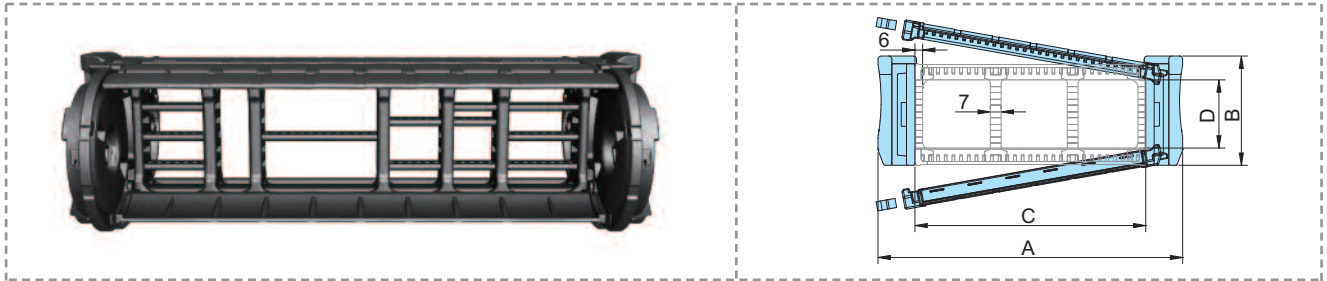

Chain Type	A	B	C	D	Bending Radius(R)	Weight in kg/m
ST 120ES.150	218		150			6.28
ST 120ES.200	268	115	200	76	200, 250, 300, 350, 400, 500	6.92
ST 120ES.250	318		7.56			
ST 120ES.300	368		8.20			

▲ 특수 프레임 적용 가능. (C:115,240,290)

▲ Application of special frame. (C:115,240,290)

### FREE END BRACKET

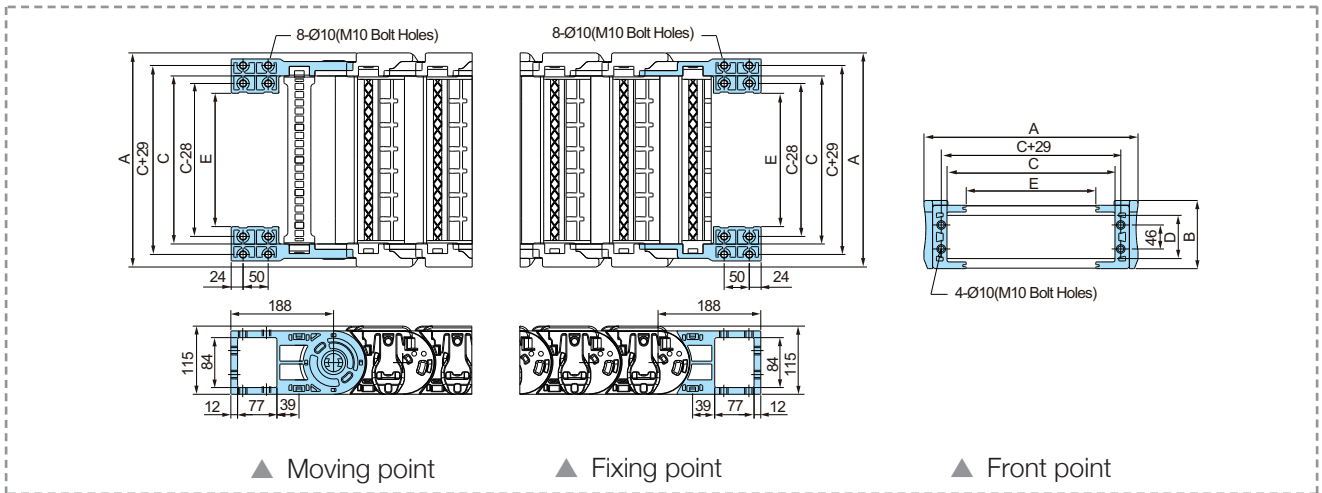

▲ Moving point

▲ Fixing point

▲ Front point

Chain Type	A	B	C	D	E	Hole Type
ST 120ES.150	218		150		90	M10 Bolt Holes
ST 120ES.200	268	115	200	76	140	
ST 120ES.250	318		190			
ST 120ES.300	368		240			

▲ 특수 프레임 적용 가능. (C:115,240,290)

▲ Application of special frame. (C:115,240,290)

## Enclosed Skid Type **ST 120ES**

CP5 CABLE CHAIN

SHIFT CHAIN

SABIN CHAIN

REVOLVING CHAIN

HELIX CHAIN

ROBO-KIT

CP5FLEX

CP5FIX

### **DIVIDERS**

Dividers (Vertical) and Separators (Horizontal) divide the inner chamber of the cable chain to give each cable diameter its own center and keep the cables separated from each other. The use of separator in some cases, can also reduce the width requirements as two or more levels can be made within the same chamber. To prevent twisting or damage to the cables, as a rule, there needs to be at least 10% space between the inserted cable and its enclosure.

디바이더(세로분리대)와 세퍼레이터(가로분리대)는 체인내에 많은 케이블들이 입선될 시 케이블들을 서로 분리하여 케이블상호간의 마찰로 인한 **피복손상 및 단선을 방지하는 역할**을 하며 케이블과 10%이상의 여유공간을 확보해야 합니다.

또한 케이블을 체인내 2단이상 입선시 반드시 세퍼레이터를 디바이더에 결합하여 사용하여 케이블의 꼬임방지와 피복손상을 방지할 수 있습니다.

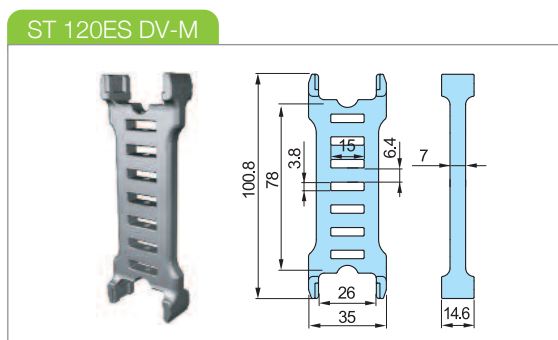
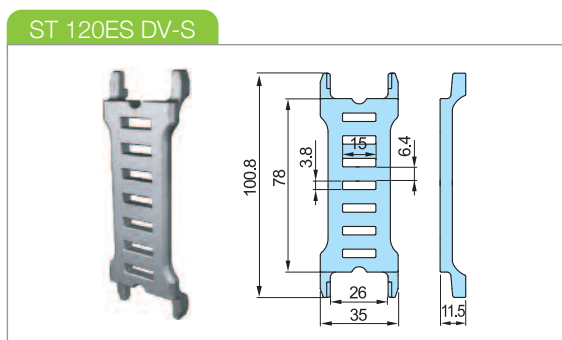

\*Assemble divider every Two links. / 2링크마다 1개씩 결합

### **SEPARATORS (SP)**

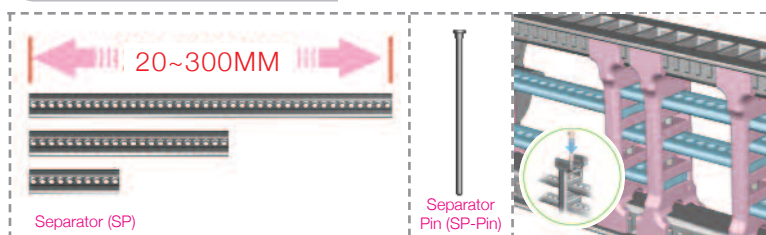

Separator is available in length from 20mm to 300mm and can be cut every 5mm for use. The combined use of divider and separator with the pin creates the most effective cable pattern and keep insertion space for cables safely, so it protects the inserted cables.

세퍼레이터의 사용길이는 최소20mm부터 최대300mm까지 사용가능하며 **5mm간격으로 절단**하여 원하는 길이로 사용가능합니다. 크기가 각각 다른 케이블을 크기에 맞게끔 공간분할이 용이하고 **세퍼레이터 핀으로 결합**하여 어떠한 경우에도 안전하게 케이블의 입선공간을 유지하여 안전하게 케이블을 보호할 수 있습니다.

### **TIE WRAP**

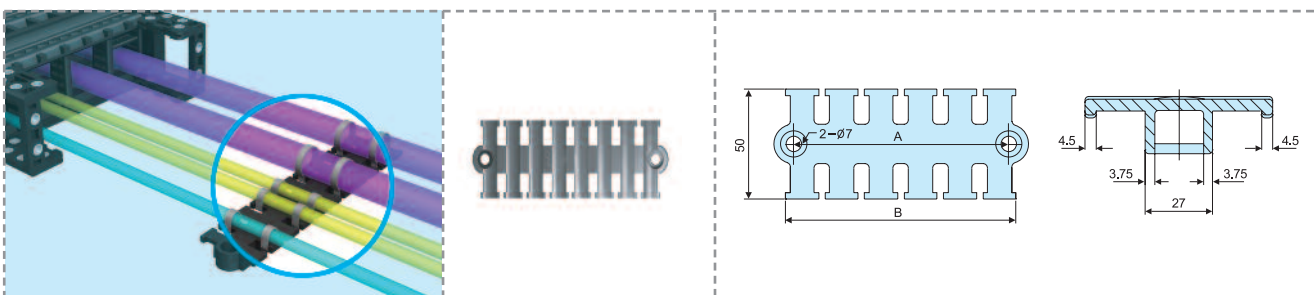

(Dimensions in mm)

Tie Wrap	050	075	100	125	150
A	58	75	98	122	141
B	65	82	105	129	148

The Tie Wrap separated from the Shift Chain bracket, when installed properly, protects the inserted cables from becoming entangled and twisted during operation

Tie Wrap은 Shift Chain의 브라켓을 기준으로 바깥으로 설치함으로써 체인의 움직임으로 인해 **케이블의 유동을 방지하고자 고정하는 시스템**으로 케이블의 피복손상 및 단선을 방지하는 역할을 합니다.



## Enclosed Skid Type **ST 120ES**

### GUIDE CHANNEL

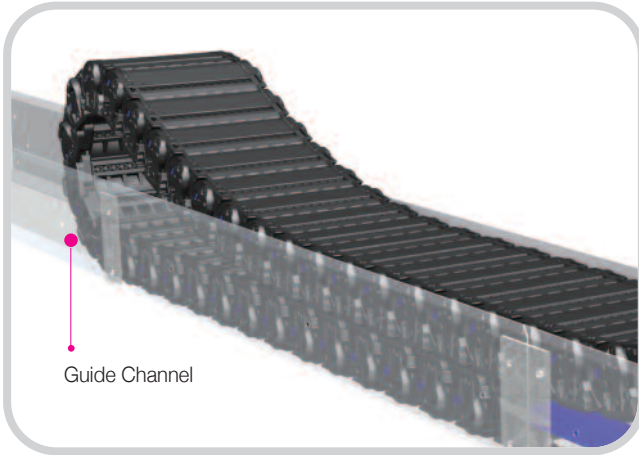

Guide Channel

For long stroke applications the guide channel is applied to ensure that the Shift Chain Sliding Chain stays on track and to ensure safety during operation. With the application of a rubber pad on the channel floor, noise is reduced to a minimum. Guide Channels are made of Steel + Zn and can be customized with SUS material.

Steel Guide Channel은 장거리 이동형 ST 120ES Type 전용으로 Chain의 이탈을 방지하는 가이드 역할을 하며 Chain 이동시 소음을 줄이기 위해 Guide Channel 바닥면에 고무패드를 사용함으로써 소음을 일정부분 억제 시키는 역할을 합니다. Guide Channel의 재질은 스틸 + 아연도금으로 제작되며 SUS재질로 주 문제작 가능합니다.

▶ Thickness can be changed by the product standards of material. (두께는 원재료의 생산규격에 따라 달라질 수 있습니다.)

### ST 120ES Type

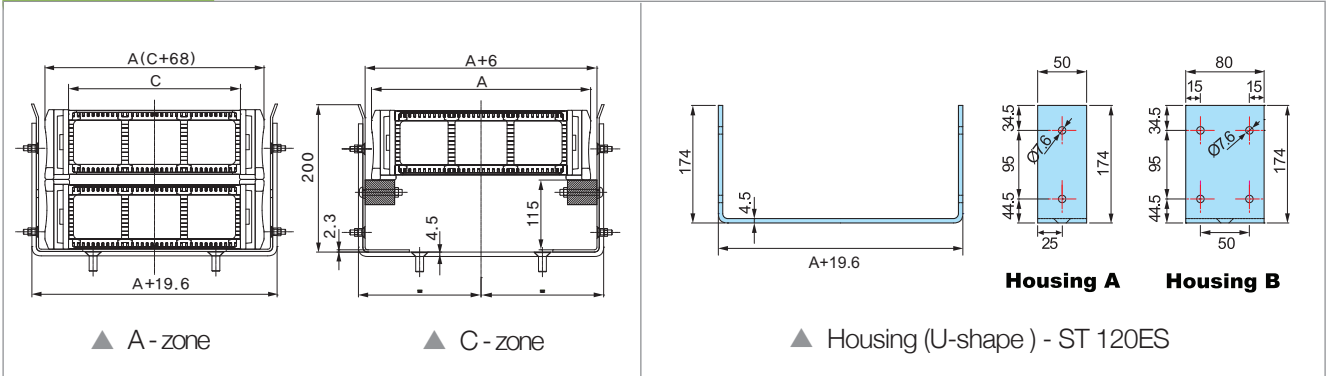

### ST 120ES Side Panel

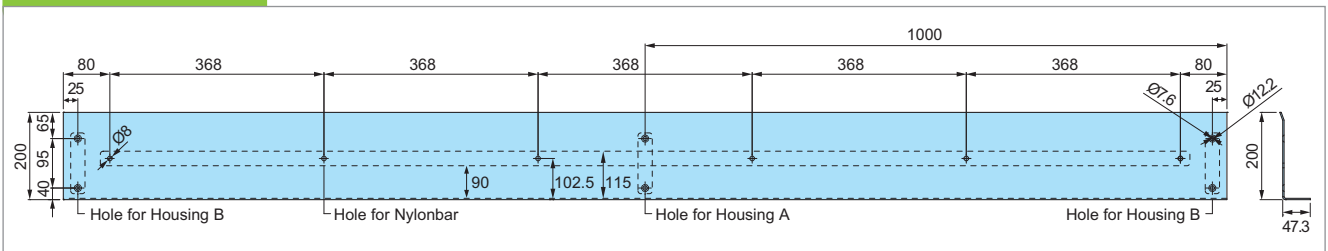

### ORDERING (주문방법)

## ST-GCS 120ES.200 / A, B, C : 200M

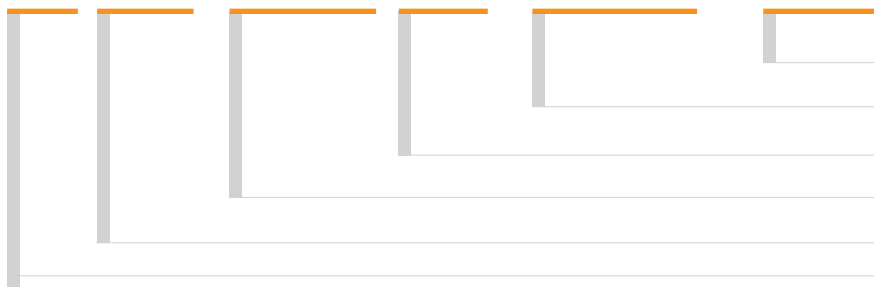

길이      Length(mm)  
 사이드판넬 종류      Panel A, B, C-Zone  
 내폭      Inside Width  
 체인종류      Chain Type  
 Steel Guide Channel  
 Shift Chain



## ASSEMBLY PROCEDURE / ENCLOSED SKID Type

Assembly procedure of Shift chain ES-type is as follows. The assembling process of shift Chain ES Type is like below and you must use rubber hammer with careful combination of Divider and Separator. (Disassembly process for repair and replacement are in reverse order)

Shift chain ES-type의 조립 순서는 아래와 같이 진행한다. 반드시 규정된 고무망치를 사용하여야 하며 케이블의 입선 수량에 따라 디바이더와 세퍼레이터를 조합하여 지정된 위치에 조립한다. (보수 및 교체를 위한 제품 분해 등은 조립의 역순)



### 1.

Insert BR Unit into each Side Band.

(Side Band is divided into right and left side according to the direction.)

사이드밴드에 사양에 맞는 BR을 홈에 맞게 조립한다. (사이드 밴드는 방향에 따라 LH, RH로 구분됨)

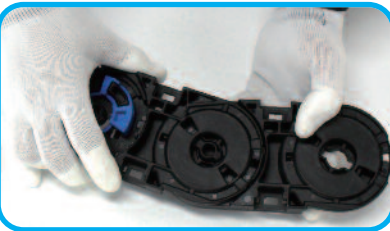

### 2.

Continue to insert BR Unit into Side Band as you want to make it. Assemble Side Band which is inserted BR Unit as above.

조립하고자 하는 사이드밴드에 모두 BR을 조립한다. BR이 삽입되어 있는 사이드밴드를 사진과 같이 조립한다.

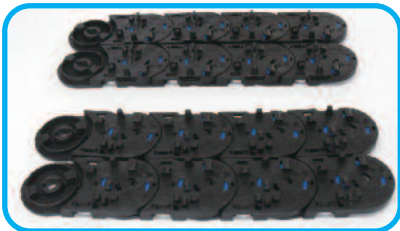

### 3.

Continue to connect each Side Band as long as you want to make it.

Connect the Side Band as many as you need.

일정단위의 길이만큼 사이드밴드를 연결한다. 조립하고자 하는 길이만큼 사이드밴드를 연결한다.

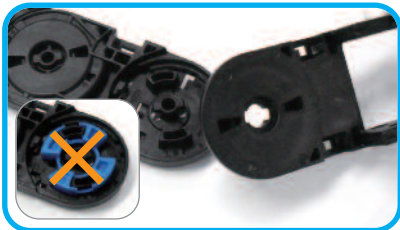

### 4.

Assemble the F.FEB according to the direction of right and left side.

-Do not insert the BR Unit to Side Band connected to F.FEB (Side of F.FEB is not enclosed.)

F.FEB를 좌우 방향에 맞도록 조립한다.

(F.FEB와 연결되는 사이드 밴드에는 BR을 삽입하지 않으며, F.FEB는 측면이 밀폐되어 있지 않음)

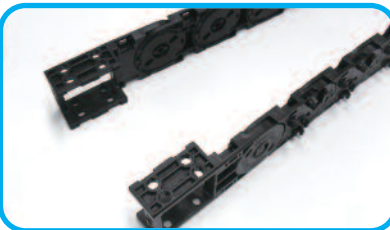
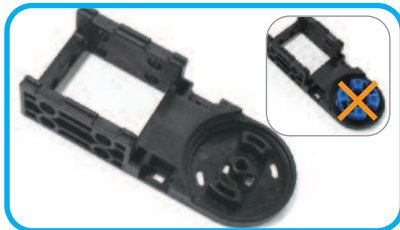

### 5.

Do not insert a BR to M.FEB. (M.FEB will be making a turn to up and down) Assemble the M.FEB according to the direction of right and left side. (Side of M.FEB is not enclosed)

M.FEB에는 BR을 삽입하지 않는다.(M.FEB가 상하 방향으로 꺾임.) / M.FEB를 좌우 방향에 맞도록 조립한다.(M.FEB는 측면이 밀폐되어 있지 않음)



### 6.

Insert one ⑥ Shaped-FRD into F.FEB.

[ ①: Normal FRD ⑥: Built-up only for F.FEB]

-Find one ⑥ shaped-FRD and insert it with the hinge facing RH direction, as above.

F.FEB에 삽입되는 FRD(⑥)를 힌지가 RH방향에 삽입되도록 조립한다.(①: FRD 일반형, ⑥: F.FEB에만 조립)

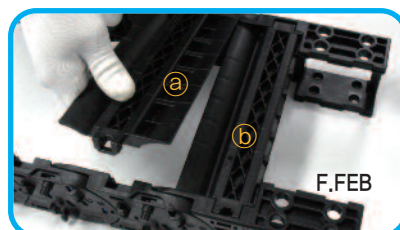

### 7.

Continue to insert the FRD( ① -Normal FRD)with the hinge facing RH direction,

-Assemble the from F.FEB to M.FEB in order.

FRD(① -일반형)을 힌지가 RH방향에 삽입되도록 연속하여 조립한다. (FRD는 F.FEB에서 시작하여 순차적으로 M.FEB 방향으로 조립하여야 함)



## ASSEMBLY PROCEDURE / ENCLOSED SKID Type

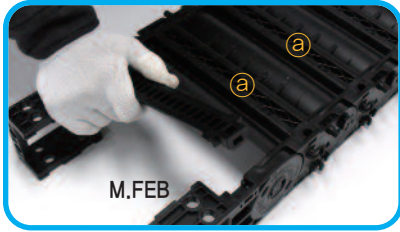

**8.**

Insert the frame as many as you need and insert them one by one with the hinge facing RH direction, as above. (M.FEB is not turned to up and down when FRD assembling)

M.FEB에 Normal Frame을 힌지가 RH방향에 삽입되도록 조립한다.  
(Normal Frame이 아닌 FRD를 조립시 M.FEB가 상하방향으로 꺾이지 않음)

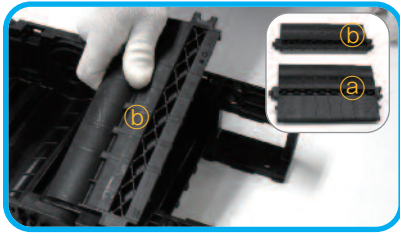

**9.**

Insert the (b) shaped-FRD inserted to F.FEB and insert it with the hinge facing RH direction, as above. (a: Normal FRD b: Built-up only for F.FEB) Insert the divider with separator to divide the inside of chain.

F.FEB에 삽입되는 FRU(b)를 힌지가 RH방향에 삽입되도록 조립한다.(a: FRU 일반형, b: F.FEB에만 조립) 내부 공간분리를 위하여 세퍼레이터가 결합된 디바이더를 삽입한다.

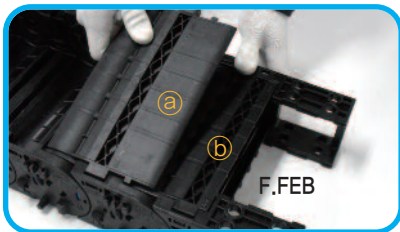

**10.**

Continue to insert the FRU (a: Normal FRU) with the hinge facing RH direction, -Assemble the from F.FEB to M.FEB in order.

FRU(a: 일반형)을 힌지가 RH방향에 삽입되도록 연속하여 조립한다.(FRU는 F.FEB에서 시작하여 순차적으로 M.FEB 방향으로 조립하여야 함)

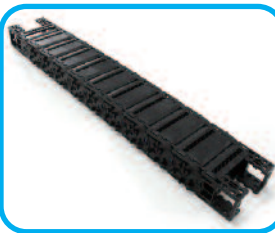
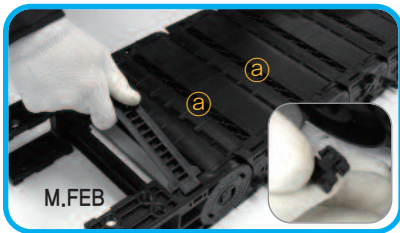

**11.**

Insert (a) Normal FRU as many as you need and insert them one by one with the hinge facing RH direction, as above. Insert Frame-pin into the hole which is seen where the end of FRU and Side Band meet. (M.FEB is not turning to up and down) when FRU assembling) Check that FRU and FRD are assembled correctly.

M.FEB에 Frame을 힌지가 RH방향에 삽입되도록 조립 후 사이드밴드의 측면에 프레임 핀을 삽입하여 프레임을 고정한다. (FRU를 조립시 M.FEB가 상하방향으로 꺾이지 않음) FRU와 FRD가 모두 조립되었는지 확인한다.

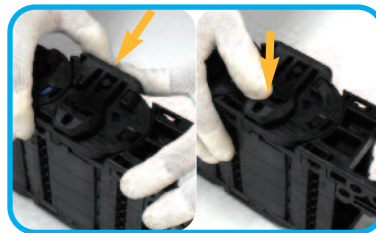
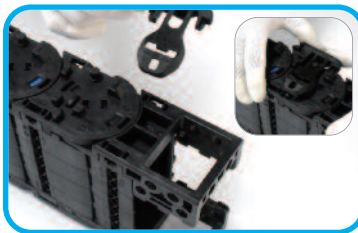

**12.**

Insert Skid into mounted Side Band. Insert Skid into groove of Side Band until you hear the "click". (Skid is also divided into LH and RH)

사이드 밴드 측면의 돌출된 형상에 스키드를 삽입하여 조립한다. 스키드를 삽입 시 사진처럼 사이드밴드의 홈에 밀어 넣은 후에 스키드 상부를 "딸깍" 소리가 나도록 눌러 고정한다. (스키드는 좌우 구분이 있음)



**13.**

Insert the Skid to all Side band in same way. Insert the Skid to opposite side of each Side Band in the same way.

연결된 모든 사이드 밴드에 스키드를 동일한 방법으로 조립한다. 반대 방향의 사이드 밴드에 스키드를 동일한 방법으로 조립한다.

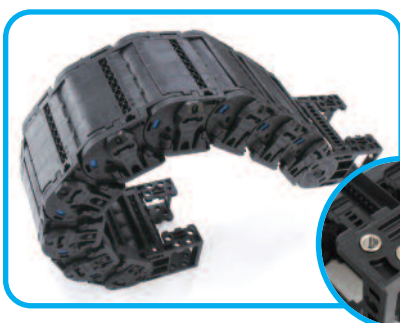

**14.**

Insert steel washers into M.FEB and F.FEB. FEB의 고정 방향에 맞도록 보강와샤를 삽입한다.