

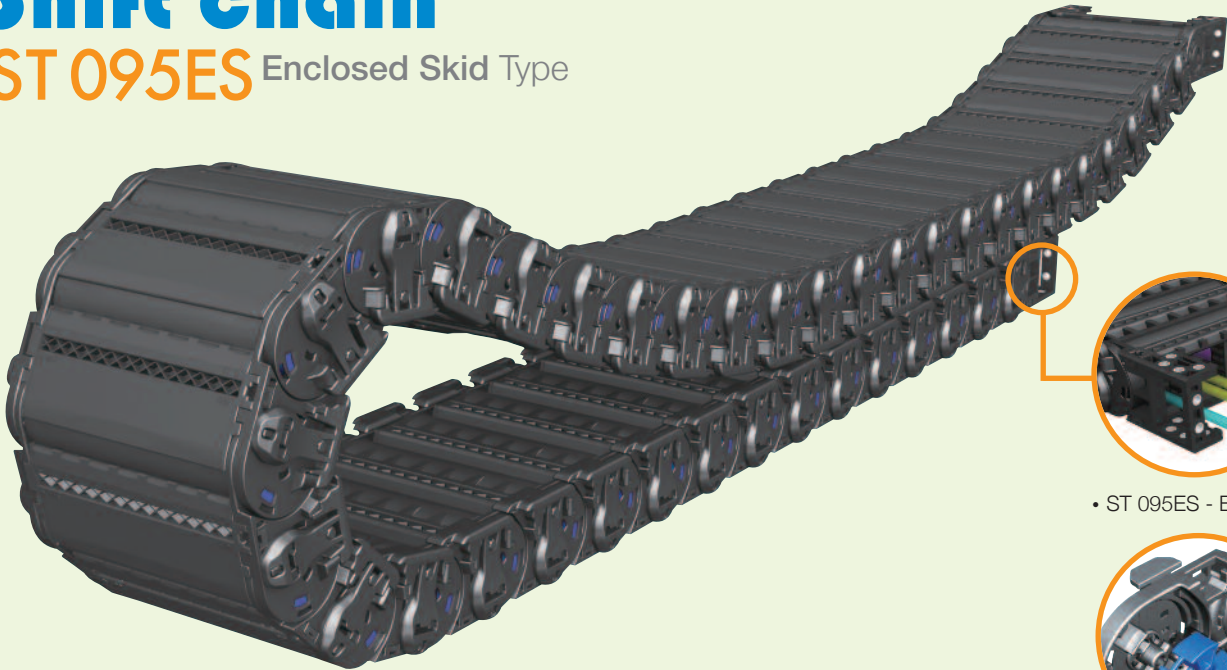

Min ●●●●●●● Max

## Shift chain® ST 095ES Enclosed Skid Type



• ST 095ES - Bracket •

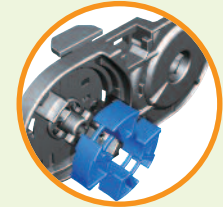

• Bending Radius Unit •

CPS CABLE CHAIN

SHIFT CHAIN

SABIN CHAIN

REVOLVING CHAIN

HELIX CHAIN

ROBO-KIT

CPSFLEX

CPSFIX

### MATERIAL

- **Chain material:**  
CPS-polyamide with glass fiber reinforced UL94-HB
- **Low Noise & Low Mote:**  
Skid 사용으로 소음 감소
- **Temperature :** -30°C ~ +130°C
- **Coefficient of Friction :**  
0.3 ~ 0.4 μ
- **Applications**

Facilities and equipments requiring a long travel distance as below; Gantry Robots, Robot Carriages, Automatic Welding Lines, Gantry Cranes, Gantry loader, etc.

Gantry robots, Robot carriages, Automatic welding Gantry crane, Gantry loader..등  
설치 장비의 케이블이 장거리 이동을 요구하는 사업장에 케이블 보호가 필요할 때 적용.

Shift Chain ES-Type can be found on car manufacturer's welding line, where excess material can damage your inserted cables.  
산업 현장, 외부 위험 요소로부터 케이블의 보호가 필요한 용접 라인, 도장 라인 등에 적용,  
외부위험 요소로부터 케이블의 보호가 요구되는 케이블 체인의 적용 사업장에 사용 가능.

### Calculation of the chain length

$$\left[ L = \frac{L_s}{2} + L_p \right]$$

Affer enclosed frame of sliding type, it can protect cable perfectly from outside, substance for long distance application.

Sliding 방식의 밀폐형 프레임을 적용하여 설비의 장거리구 동시에도 외부 이물질로부터 Cable을 완벽하게 보호하도록 설계됨.



## Enclosed Skid Type **ST 095ES**

### LAYOUT OF THE CHAIN

Ls: Stroke   Lp: Loop Length   Lf: Loop Projection

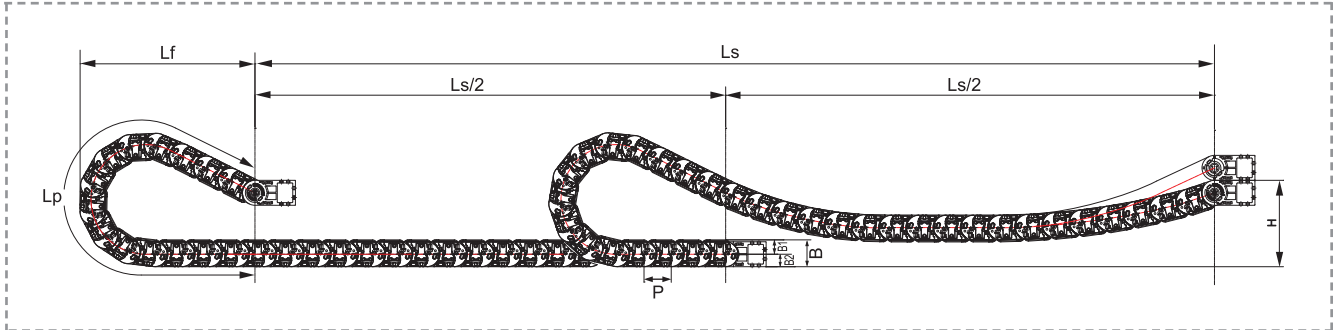

(Dimensions in mm)

Bending radius R	150	200	230	280	400
Lp	1,178	1,479	1,666	2,146	3,232
L f	534	634	694	889	1319
H	250	250	250	250	250

### ST 095ES Type

Pitch P: 95mm  
 Height B: 89mm  
 B1: 48mm  
 B2: 41mm

### ORDERING (주문방법)

## ST 095ES.200.R200 / F-10000L:10ST



주문수량	Q'ty(set)
체인길이	Length(mm)
브라켓	Free End Bracket
곡률반경	Bending Radius
내폭	Inside Width
장거리타입(ES)	Enclosed Skid Type
<b>Shift Chain</b>	

### BRACKET TYPE (브라켓타입)

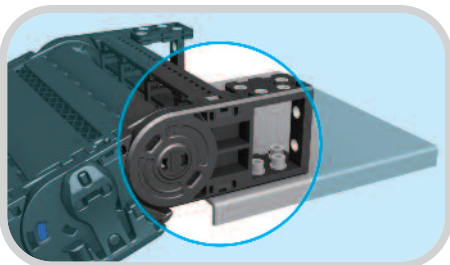
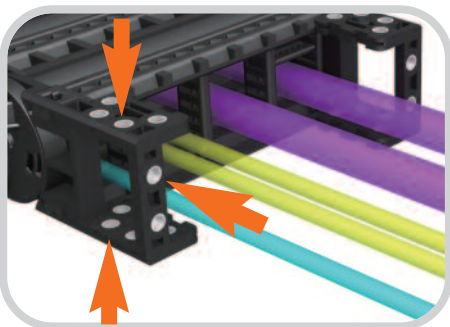

### FEB (Free End Bracket)

FEB Fixes the cable chain to the machinery or moving application. CPS has improved mounting efficiency by unifying the existing Easy End Bracket and Normal End Bracket.

The End Bracket is designed to move up and down as the cable chain or application requires. To add strength, steel washers are inserted into the fixing holes of each Free End Bracket.

체인을 고정하는 끝부분으로 기존 Easy End Bracket 과 Normal End Bracket을 하나로 통합한 방식으로 취부의 효율성을 높임.

장거리 이동용 ST ES-Type에 적용되는 Free End Bracket은 곡률반경을 자유롭게 형성하여 브라켓 부위의 파손을 방지하며 또한 스틸와셔를 결합하여 더욱 견고한 취부가 가능하다.

- ▶ BR should not be inserted in the joint of side band and Free End Bracket FEB와 결합하는 Side Band에는 BR을 삽입하지 않음.
- ▶ Normal Frame, not FRU/FRD, is inserted into M.FEB. M.FEB에는 밀폐형 Frame(FRU/FRD)이 아닌 일반형 Frame이 삽입됨.
- ▶ Above products are patent registered item which can be protected by industrial property right. (상기제품은 특허등록 제품으로 산업재산권의 보호를 받는 제품입니다.)

## Enclosed Skid Type **ST 095ES**

### CHAIN CROSS SECTION



Chain Type	A	B	C	D	Bending Radius(R)	Weight in kg/m
ST 095ES.100	162		100		150, 200, 230, 280, 400	4.16
ST 095ES.125	187		125			4.41
ST 095ES.150	212	89	150	55		4.65
ST 095ES.175	237		175			4.90
ST 095ES.200	262		200			5.15

▲ 특수 프레임 적용 가능. (C:190,240)

▲ Application of special frame. (C:190,240)

### FREE END BRACKET

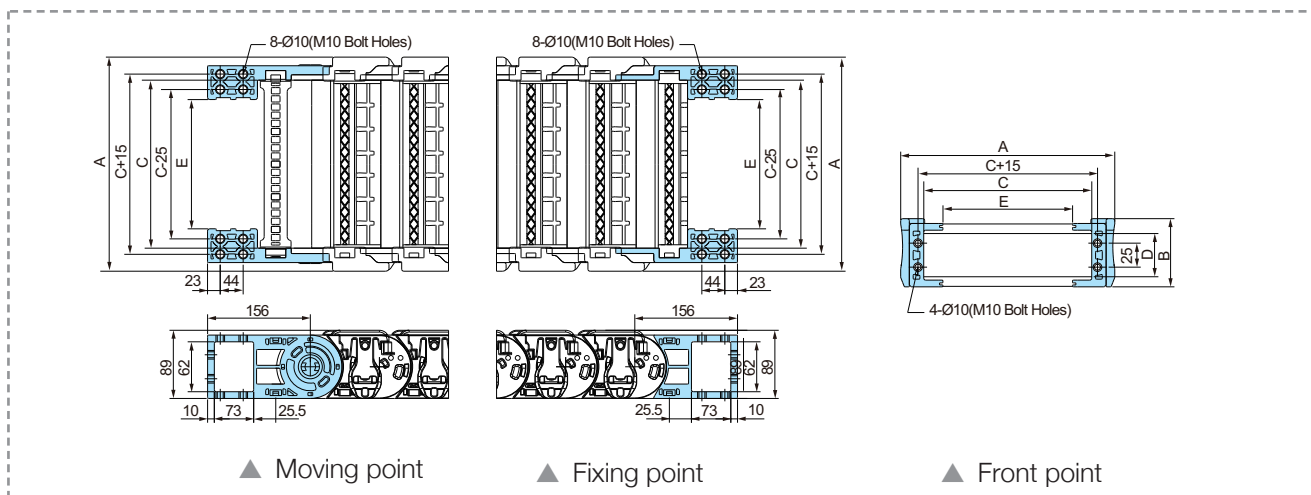

▲ Moving point

▲ Fixing point

▲ Front point

Chain Type	A	B	C	D	E	Hole Type
ST 095ES.100	162		100		49	M10 Bolt Holes
ST 095ES.125	187		125		74	
ST 095ES.150	212	89	150	55	99	
ST 095ES.175	237		175		124	
ST 095ES.200	262		200		149	

▲ 특수 프레임 적용 가능. (C:190,240)

▲ Application of special frame. (C:190,240)



## Enclosed Skid Type **ST 095ES**

### DIVIDERS

Dividers (Vertical) and Separators (Horizontal) divide the inner chamber of the cable chain to give each cable diameter its own center and keep the cables separated from each other. The use of separator in some cases, can also reduce the width requirements as two or more levels can be made within the same chamber. To prevent twisting or damage to the cables, as a rule, there needs to be at least 10% space between the inserted cable and its enclosure.

디바이더(세로 분리대)와 세퍼레이터(가로 분리대)는 체인 내에 많은 케이블들이 입선될 시 케이블들을 서로 분리하여 케이블상 호간의 마찰로 인한 **피복 손상 및 단선**을 방지하는 역할을 하며 케이블과 10%이상의 여유 공간을 확보해야합니다.

또한 케이블을 체인 내 2단 이상 입선 시 반드시 세퍼레이터를 디바이더에 결합하여 사용해야 케이블의 꼬임 방지와 피복 손상을 방지할 수 있습니다.

ST 095ES DV-S

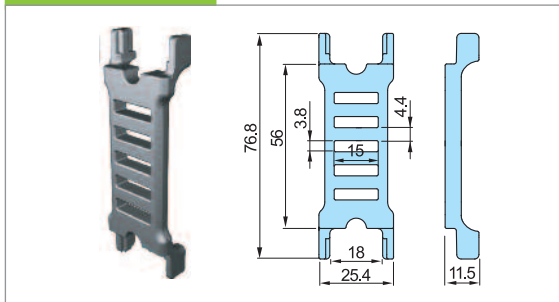

ST 095ES DV-M

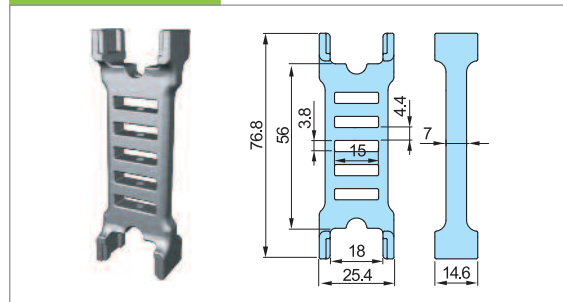

\*Assemble divider every Two links. / 2링크마다 결합

### SEPARATORS (SP)

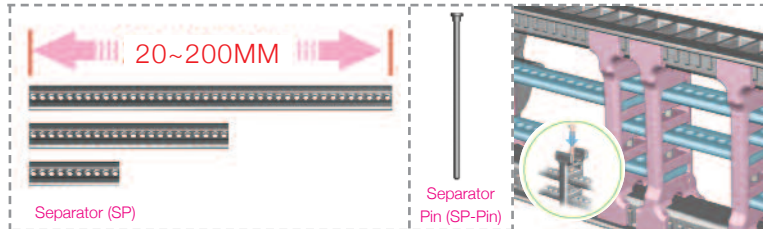

Separator is available in length from 20mm to 200mm and can be cut every 5mm for use. The combined use of divider and separator with the pin creates the most effective cable pattern and keep insertion space for cables safely, so it protects the inserted cables.

세퍼레이터의 사용길이는 최소20mm부터 최대200mm까지 사용가능하며 5mm간격으로 절단하여 원하는 길이로 사용가능합니다. 크기가 각각 다른 케이블을 크기에 맞게끔 공간분할이 용이하고 세퍼레이터 핀으로 결합하여 어떠한 경우에도 안전하게 케이블의 입선공간을 유지하여 안전하게 케이블을 보호할 수 있습니다.

### TIE WRAP

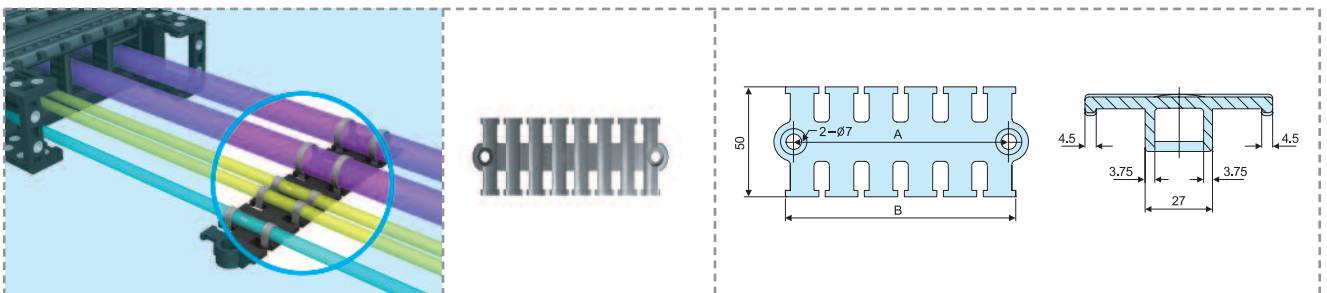

(Dimensions in mm)

Tie Wrap	050	075	100	125	150
A	58	75	98	122	141
B	65	82	105	129	148

The Tie Wrap separated from the Shift Chain bracket, when installed properly, protects the inserted cables from becoming entangled and twisted during operation

Tie Wrap은 Shift Chain의 브라켓을 기준으로 바깥으로 설치함으로써 체인의 움직임으로 인해 **케이블의 유동을 방지하고자 고정하는 시스템**으로 케이블의 피복손상 및 단선을 방지하는 역할을 합니다.



## Enclosed Skid Type **ST 095ES**

### GUIDE CHANNEL

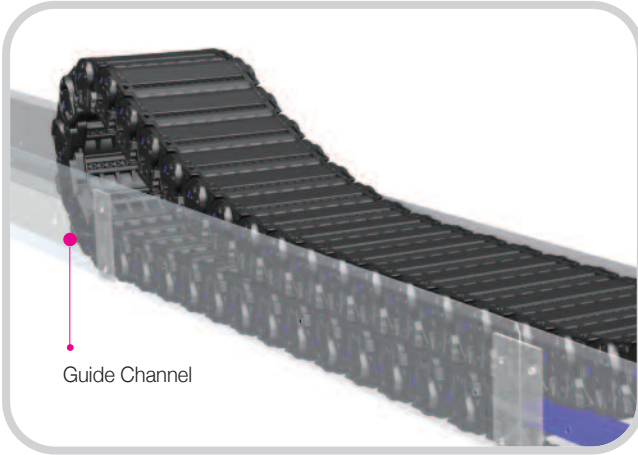

Guide Channel

For long stroke applications the guide channel is applied to ensure that the Shift Chain Sliding Chain stays on track and to ensure safety during operation. With the application of a rubber pad on the channel floor, noise is reduced to a minimum. Guide Channels are made of Steel + Zn and can be customized with SUS material .

Steel Guide Channel은 장거리 이동형 ST 095ES Type 전용으로 Chain의 이탈을 방지하는 가이드 역할을 하며 Chain 이동시 소음을 줄이기 위 Guide Channel 바닥면에 고무패드를 사용함으로써 소음을 일정부분 억제 시키는 역할을 합니다. Guide Channel의 재질은 스틸 + 아연도금으로 제작되며 SUS 재질로 주 문제작 가능합니다.

▶ Thickness can be changed by the product standards of material.  
( 두께는 원재료의 생산규격에 따라 달라질 수 있습니다. )

### ST 095ES Type

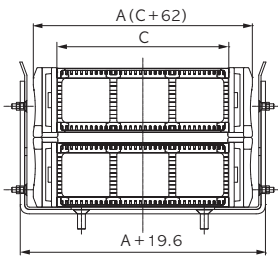

▲ A - zone

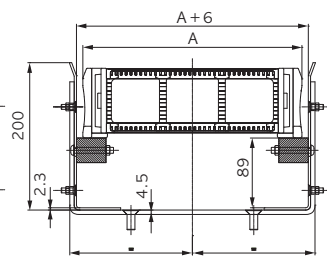

▲ C - zone

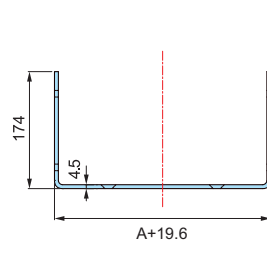

▲ Housing (U-shape) - ST 095ES

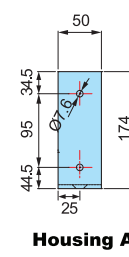

Housing A

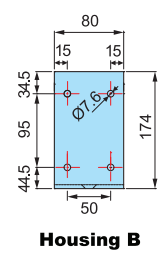

Housing B

### ST 095ES Side Panel

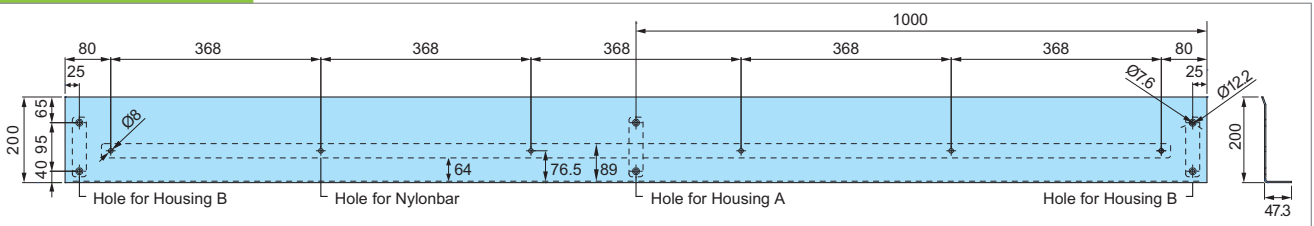

### ORDERING (주문방법)

## ST-GCS 095ES.175 / A, B, C : 200M



길이	Length(mm)
사이드판넬 종류	Panel A, B, C-Zone
내폭	Inside Width
체인종류	Chain Type
Steel Guide Channel	
Shift Chain	