

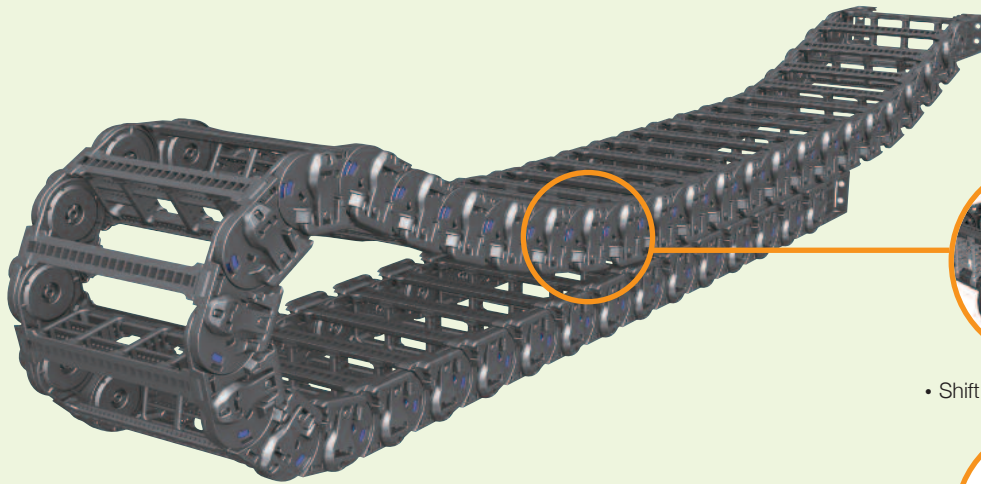

## Shift chain<sup>®</sup> ST 044S Skid Type

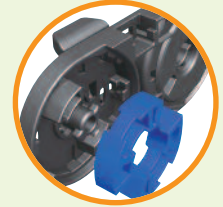

• Shift chain S-Type 분해도 •



• Bending Radius Unit •

### MATERIAL

- **Chain material:**  
CPS-polyamide with glass fiber reinforced UL94-HB
- **Low Noise & Low Mote:**  
Skid사용으로 소음 감소
- **Temperature :** -30°C ~ +130°C
- **Coefficient of Friction :**  
0.3 ~ 0.4 μ

### Applications

- Facilities and equipments requiring a long travel distance as below; Gantry Robots, Robot Carriages, Automatic Welding Lines, Gantry Cranes, Gantry loader, etc.  
Gantry robots, Robot carriages, Automatic welding Gantry crane, Gantry loader 등  
설치 장비의 케이블이 장거리 이동을 요구하는 사업장에 케이블 보호가 필요할 때 적용.

### Calculation of the chain length

$$\left[ L = \frac{Ls}{2} + Lp \right]$$

After using skid for a long time, it can be replaced without extra components.

스키드 장착으로 장시간 사용 후 Skid를 교체할 수 있고, Skid는 별도의 부품없이 조립이 가능함.



## Skid Type **ST 044S**

### LAYOUT OF THE CHAIN

LS: Stroke   Lp: Loop Length   Lf: Loop Projection

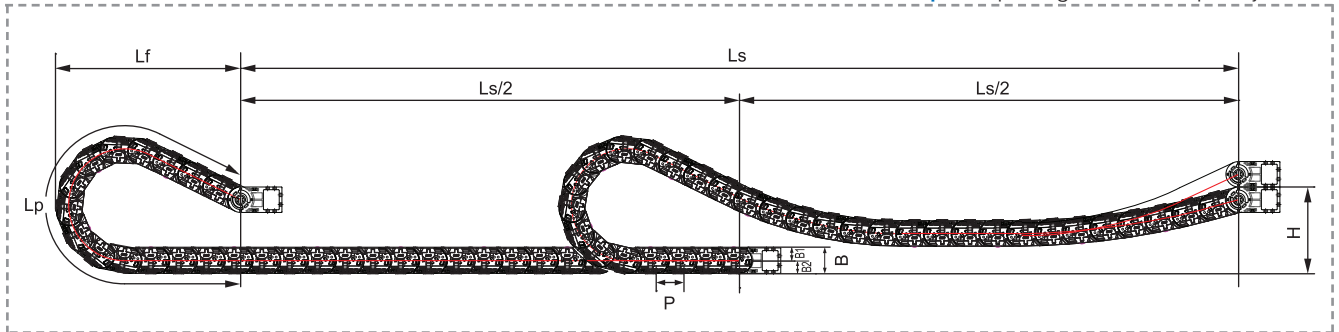

(Dimensions in mm)

Bending radius R	70	90	120	150
Lp	544	662	926	1,190
Lf	249	289	393	497
H	130	130	130	130

### ST 044S Type

Pitch P: 44mm  
 Height B: 38.5mm  
 B1: 19.5mm  
 B2: 19mm

### ORDERING (주문방법)

## ST 044S. 100. R120 / F - 1500L : 10ST

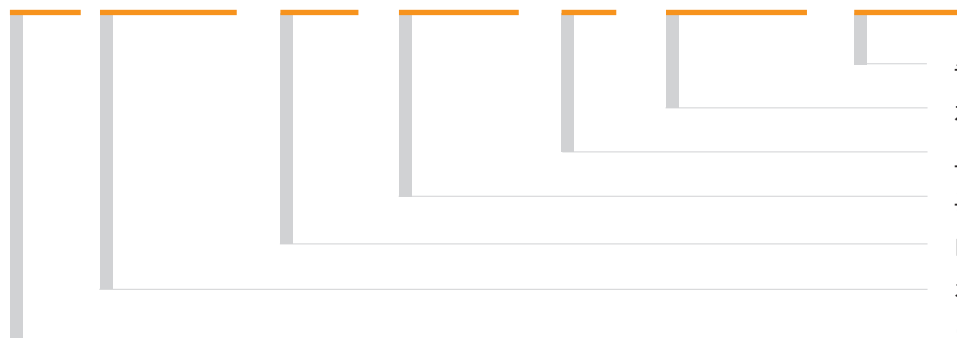

주문수량      Q'ty(set)  
 체인길이      Length(mm)  
 브라켓      Free End Bracket  
 곡률반경      Bending Radius  
 내폭      Inside Width  
 장거리타입(S)      Skid Type  
**Shift Chain**

### BRACKET TYPE (브라켓타입)

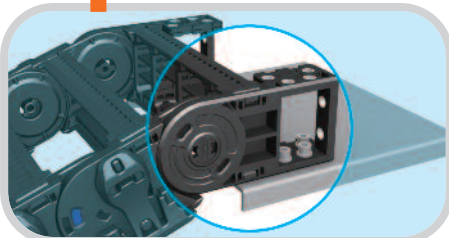
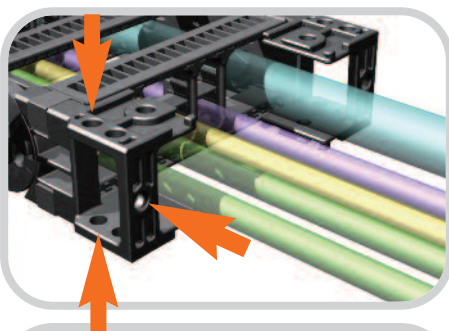

### FEB (Free End Bracket)

FEB Fixes the cable chain to the machinery or moving application. CPS has improved mounting efficiency by unifying the existing Easy End Bracket and Normal End Bracket.

The End Bracket is designed to move up and down as the cable chain or application requires.

체인을 고정하는 끝부분으로 기존 Easy End Bracket과 Normal End Bracket을 하나로 통합한 방식으로 취부의 효율성을 높임.

장거리 이동용 ST S-Type에 적용되는 Free End Bracket은 곡률반경을 자유롭게 형성하여 브라켓 부위의 파손을 방지.

▶ BR should not be inserted in the joint of side band and Free End Bracket. FEB와 결합하는 Side Band에는 BR을 삽입하지 않음.

▶ Above products are patent registered item which can be protected by industrial property right. (상기제품은 특허등록 제품으로 산업재산권의 보호를 받는 제품입니다.)



## Skid Type **ST 044S**

### CHAIN CROSS SECTION



Chain Type	A	B	C	D	Bending Radius(R)	Weight in kg/m
ST 044S.035	74		35			
ST 044S.050	89		50			
ST 044S.055	94		55			
ST 044S.075	114		75			
ST 044S.100	139	38.5	100	26	70, 90, 120, 150	-
ST 044S.125	164		125			
ST 044S.150	189		150			
ST 044S.175	214		175			
ST 044S.200	239		200			

### FREE END BRACKET

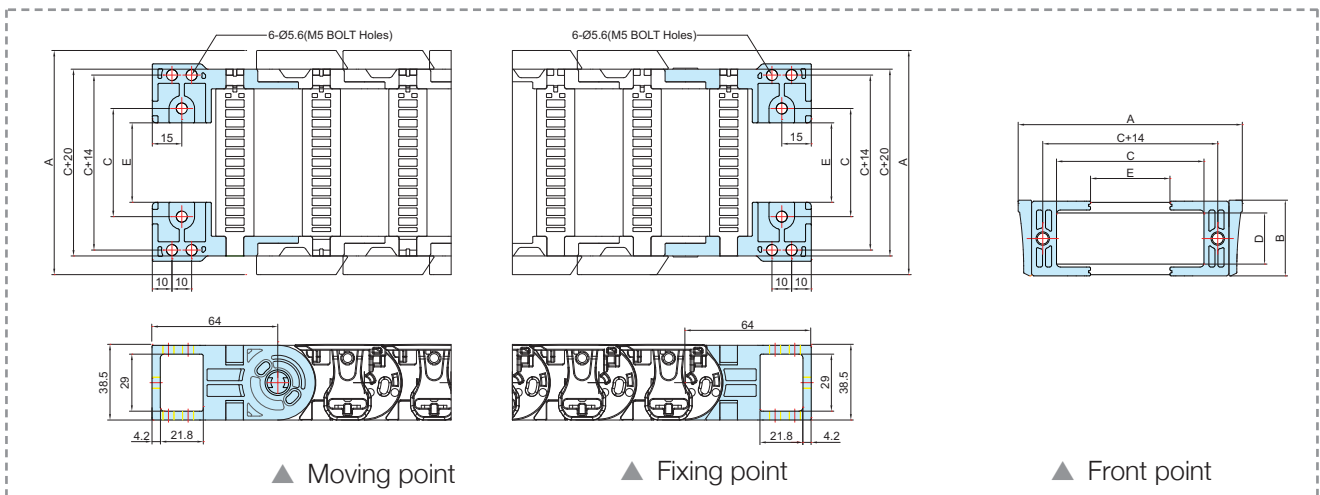

Chain Type	A	B	C	D	E	Hole Type
ST 044S.035	74		35		0.4	
ST 044S.050	89		50		15.4	
ST 044S.055	94		55		20.4	
ST 044S.075	114		75		40.4	
ST 044S.100	139	38.5	100	26	65.4	M5 Bolt Holes
ST 044S.125	164		125		90.4	
ST 044S.150	189		150		115.4	
ST 044S.175	214		175		140.4	
ST 044S.200	239		200		165.4	



## Skid Type **ST 044S**

### DIVIDERS & SEPARATORS

Dividers (Vertical) and Separators (Horizontal) divide the inner chamber of the cable chain to give each cable diameter its own center and keep the cables separated from each other. The use of a separator in some cases, can also reduce the width requirements as two or more levels can be made within the same chamber. To prevent twisting or damage to the cables, as a rule, there needs to be at least 10% space between the inserted cable and its enclosure.

디바이더(세로분리대)와 세퍼레이터(가로분리대)는 체인내에 많은 케이블들이 입선될 시 케이블을 서로 분리하여 케이블상호간 마찰로 인한 **피복손상 및 단선을 방지하는 역할**을 하며 케이블과 10%이상의 여유공간을 확보해야 합니다.

또한 케이블을 체인내 2단이상 입선시 반드시 세퍼레이터를 디바이더에 결합하여 사용해야 케이블의 꼬임방지과 피복손상을 방지할 수 있습니다.

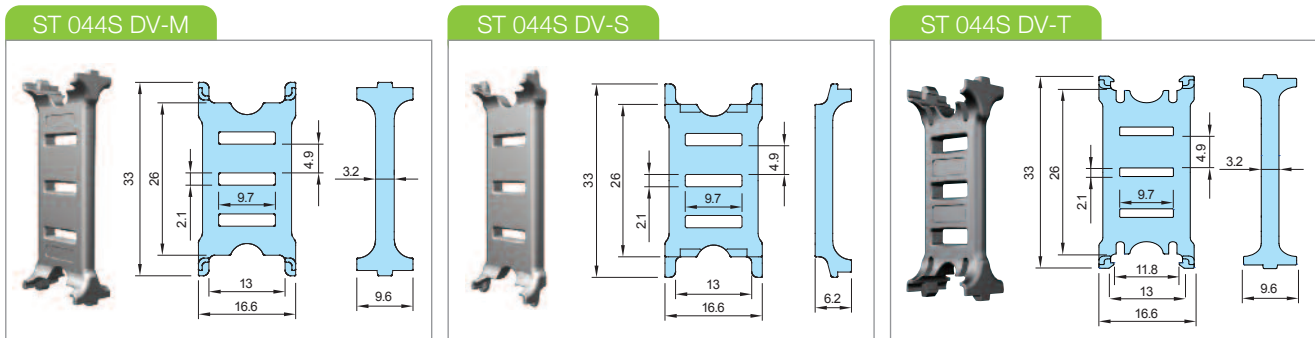

▶ Assemble divider every Two links. / 2링크마다 결합

▶ DV/T : Frame 125~200적용(상하 프레임을 연결)

### ST044S Separators (SP) (No. : S-SP/M)

Chain Type	Separators	SP035	SP050	SP055	SP075	SP100	SP125	SP150	SP175	SP200
ST 044S		○	○	○	○	○	○	○	○	○

### TIE WRAP

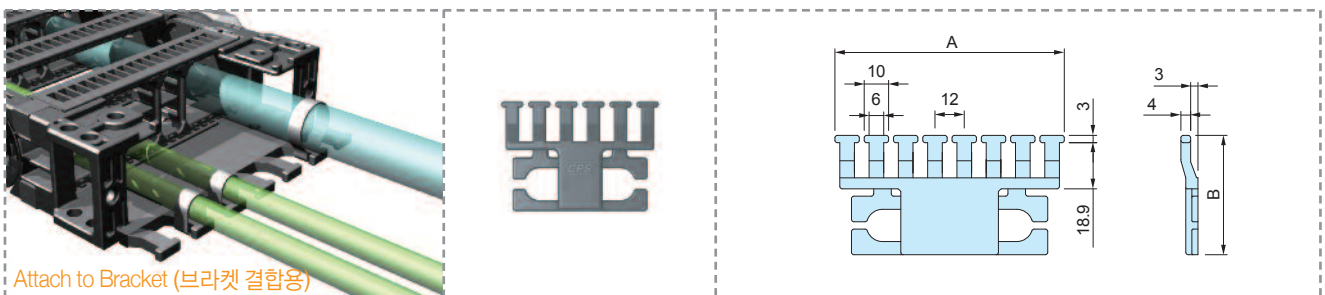

Attach to Bracket (브라켓 결합용)

(Dimensions in mm)

Tie Wrap	035	050	055	075	100	125
A	46	69.4	70	94	118	142
B	35.4	48.9	48.9	48.9	48.9	48.9

The Tie Wrap separated from the Shift Chain bracket, when installed properly, protects the inserted cables from becoming entangled and twisted during operation.

There are two types in the tie wrap; Attached & Unattached to the bracket.

Tie Wrap은 Shift Chain의 함으로써 체인의 움직임으로 인해 체인내의 케이블이나 호스가 당겨져 **단선되는 경우를 방지**할 수 있다. Shift Chain의 Tie Wrap은 **브라켓부분과 근접해서 사용할 수 있는 사양과 브라켓에 결합해서 사용할 수 있는 사양**으로 구분되어 사용할 수 있다.



## Skid Type **ST 044S**

### GUIDE CHANNEL

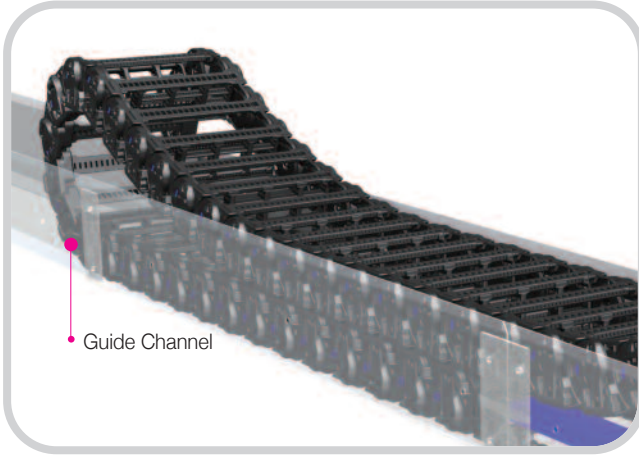

For long stroke applications the guide channel is applied to ensure that the Shift Chain Sliding Chain stays on track and to ensure safety during operation. With the application of a rubber pad on the channel floor, noise is reduced to a minimum. Guide Channels are made of Steel + Zn and can be customized with SUS material .

Steel Guide Channel은 장거리 이동형 ST044S Type 전용으로 Chain의 이탈을 방지하는 가이드 역할을 하며 Chain이동 시 소음을 줄이기 위해 Guide Channel 바닥면에 고무패드를 사용함으로써 소음을 일정 부분 억제 시키는 역할을 합니다. Guide Channel의 재질은 스틸 + 아연도금으로 제작되며 SUS재질로 주문 제작 가능합니다.

▶ Thickness can be changed by the product standards of material. ( 두께는 원재료의 생산 규격에 따라 달라질 수 있습니다. )

### ST 044S Type

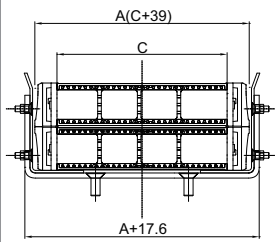

▲ A - zone

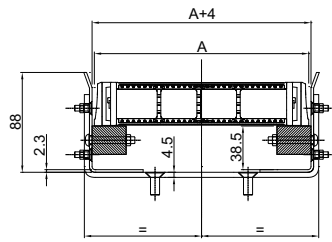

▲ C - zone

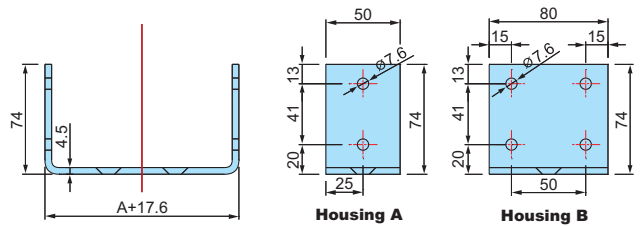

▲ Housing (U-shape) -ST 044S

### ST 044S Side Panel

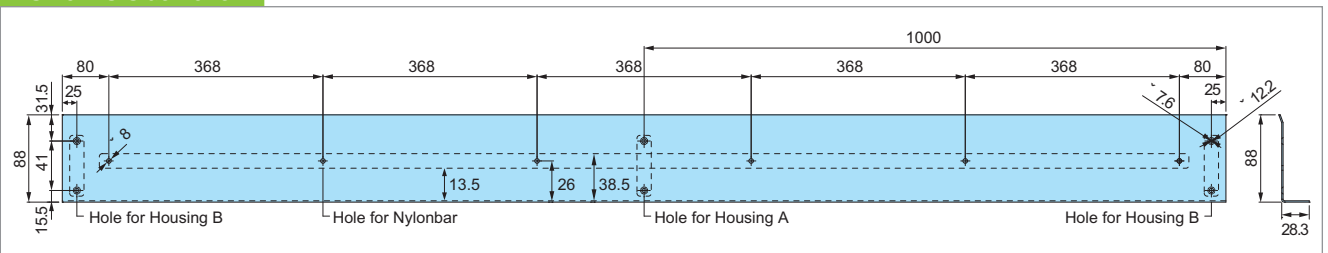

### ORDERING (주문방법)

## ST-GCS 044S. 100 / A, B, C : 200M

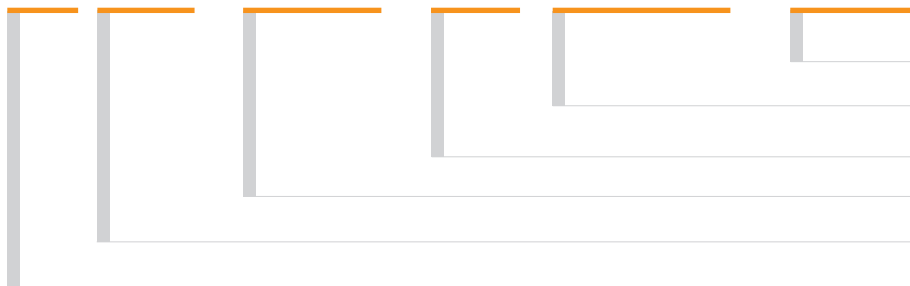

길이	Length(mm)
사이드패널 종류	Panel A, B, C-Zone
내폭	Inside Width
체인종류	Chain Type
Steel Guide Channel	
Shift Chain	