



IDENTIFICAZIONE

Le tabelle 1 a seguito riportate per ogni modello indicano: il diametro dell'albero, il rapporto di trasmissione, **l'albero di entrata A**, gli alberi di uscita B, C o D il senso di rotazione (guardando frontalmente l'albero). **L'albero A per convenzione è considerato come albero di entrata**, nei modelli con rapporto 1/2 1/3 è l'albero veloce.

IDENTIFICATION

Table 1 shows the following information for each model; the shaft diameter, the transmission ratio, **the input shaft A**, the output shaft B, C or D and the direction of rotation (front view to the shaft). **In accordance with accepted usage, shaft A is the input shaft**; on models with a 1:2 and 1:3 ratio, shaft A is the fast shaft.

TABELLA TABLE	1	mod. DZ	Albero	Rapp.	Entrata	Uscita	Modello	Peso
			Shaft	Ratio	In	Out	Model	Weight
1			Ø 8	1/1	A	B	DZ 10S-2FAB-	Kg 0.3
			Ø 8	1/1	A	C	DZ 10FS2FAC-	
			Ø 8	1/2	A	B	DZ 12S-2FAB-	
			Ø 8	1/2	A	C	DZ 12FS2FAC-	
			Ø 8	1/1	A	B - C	DZ 11-2FABC	
			Ø 8	1/2	A	B - C	DZ 13-2FABC	
1			Ø 8	1/1	A	B	DZ 10S-3FAB-	Kg 0.3
			Ø 8	1/1	A	C	DZ 10FS3FAC-	
			Ø 8	1/2	A	B	DZ 12S-3FAB-	
			Ø 8	1/2	A	C	DZ 12FS3FAC-	
			Ø 8	1/1	A	B - C	DZ 11-3FABC	
			Ø 8	1/2	A	B - C	DZ 13-3FABC	
2			Ø 15	1/1	A	B	DZ 20S-2FAB-	Kg 1.1
			Ø 15	1/1	A	C	DZ 20FS2FAC-	
			Ø 15	1/2	A	B	DZ 22S-2FAB-	
			Ø 15	1/2	A	C	DZ 22FS2FAC-	
			Ø 15	1/1	A	B - C	DZ 21-2FABC	
			Ø 15	1/2	A	B - C	DZ 23-2FABC	
2			Ø 15	1/1	A	B	DZ 20S-3FAB-	Kg 1.1
			Ø 15	1/1	A	C	DZ 20FS3FAC-	
			Ø 15	1/2	A	B	DZ 22S-3FAB-	
			Ø 15	1/2	A	C	DZ 22FS3FAC-	
			Ø 15	1/1	A	B - C	DZ 21-3FABC	
			Ø 15	1/2	A	B - C	DZ 23-3FABC	
3			Ø 19-20	1/1	A	B - C	DZ 311-3FABC	Kg 3.3
3			Ø 20	1/1	A	B	DZ 30S-3FAB-	Kg 3.4
			Ø 20	1/1	A	C	DZ 30FS3FAC-	
			Ø 20	1/2	A	B	DZ 32S-3FAB-	
			Ø 20	1/2	A	C	DZ 32FS3FAC-	
			Ø 20	1/1	A	B - C	DZ 31-3FABC	
			Ø 20	1/2	A	B - C	DZ 33-3FABC	
4			Ø 25	1/1	A	B	DZ 40S-3FAB-	Kg 5.5
			Ø 25	1/1	A	C	DZ 40FS3FAC-	
			Ø 25	1/2	A	B	DZ 42S-3FAB-	
			Ø 25	1/2	A	C	DZ 42FS3FAC-	
			Ø 25	1/1	A	B - C	DZ 41-3FABC	
			Ø 25	1/2	A	B - C	DZ 43-3FABC	
5			Ø 35	1/1	A	B	DZ 50S-3FAB-	Kg 8.1
			Ø 35	1/1	A	C	DZ 50FS3FAC-	
			Ø 35	1/2	A	B	DZ 52S-3FAB-	
			Ø 35	1/2	A	C	DZ 52FS3FAC-	
			Ø 35	1/1	A	B - C	DZ 51-3FABC	
			Ø 35	1/2	A	B - C	DZ 53-3FABC	



TABELLA TABLE	1	mod. ZP	Albero	Rapp.	Entrata	Uscita	Modello	Peso
			Shaft	Ratio	In	Out	Model	Weight
1			Ø 8	1/1	A	B	ZP 10S-4PAB-	Kg 0.6
			Ø 8	1/1	A	C	ZP 10FS4PAC-	
			Ø 8	1/2	A	B	ZP 12S-4PAB-	
			Ø 8	1/2	A	C	ZP 12FS4PAC-	
			Ø 8	1/1	A	B - C	ZP 11-4PABC	
			Ø 8	1/2	A	B - C	ZP 13-4PABC	
2			Ø 14	1/1	A	B	ZP 20S-4PAB-	Kg 2
			Ø 14	1/1	A	C	ZP 20FS4PAC-	
			Ø 14	1/2	A	B	ZP 22S-4PAB-	
			Ø 14	1/2	A	C	ZP 22FS4PAC-	
			Ø 14	1/3	A	B	ZP 24S-4PAB	
			Ø 14	1/3	A	C	ZP 24FS4PAC-	
			Ø 14	1/1	A	B - C	ZP 21-4PABC	
			Ø 14	1/2	A	B - C	ZP 23-4PABC	
2			Ø 14	1/1	A	B - C	ZP 211-4P3V-	Kg 1.9
			Ø 14	1/2	A	B - C	ZP 213-4P3V-	
			Ø 14	1/3	A	B - C	ZP 215-4P3V-	
2			Ø 14	1/1	A	B - C	ZP 220S-4PABC	Kg 3.2
			Ø 14	1/1	A	C - D	ZP 220FS4PACD	
			Ø 14	1/2	A	B - C	ZP 222S-4PABC	
			Ø 14	1/2	A	C - D	ZP 222FS4PACD	
			Ø 14	1/3	A	B - C	ZP 224S-4PABC	
			Ø 14	1/3	A	C - D	ZP 224FS4PACD	
			Ø 14	1/1	A	B - C - D	ZP 221-4PABCD	
			Ø 14	1/2	A	B - C - D	ZP 223-4PABCD	
2			Ø 14	1/1	A	B - C - D	ZP 211-4P4V-	Kg 3.1
			Ø 14	1/2	A	B - C - D	ZP 213-4P4V-	
			Ø 14	1/3	A	B - C - D	ZP 215-4P4V-	
3			Ø 19	1/1	A	B	ZP 30S-4PAB-	Kg 4.5
			Ø 19	1/1	A	C	ZP 30FS4PAC-	
			Ø 19	1/2	A	B	ZP 32S-4PAB-	
			Ø 19	1/2	A	C	ZP 32FS4PAC-	
			Ø 19	1/3	A	B	ZP 34S-4PAB-	
			Ø 19	1/3	A	C	ZP 34FS4PAC-	
			Ø 19	1/1	A	B - C	ZP 31-4PABC	
			Ø 19	1/2	A	B - C	ZP 33-4PABC	
			Ø 19	1/3	A	B - C	ZP 35-4PABC	
			Ø 19	1/1	A	B - C	ZP 311-4P3V-	
3			Ø 19	1/1	A	B - C	ZP 313-4P3V-	Kg 4.4
			Ø 19	1/2	A	B - C	ZP 315-4P3V-	
			Ø 19	1/3	A	B - C	ZP 315-4P3V-	
3			Ø 19	1/1	A	B	ZP 30 - INVERT	Kg 4.6
			Ø 19	1/1	A	B - C	ZP 31 - INVERT	
4			Ø 24	1/1	A	B	ZP 40S-4PAB-	Kg 4.6
			Ø 24	1/1	A	C	ZP 40FS4PAC-	
			Ø 24	1/2	A	B	ZP 42S-4PAB-	
			Ø 24	1/2	A	C	ZP 42FS4PAC-	
			Ø 24	1/3	A	B	ZP 44S-4PAB-	
			Ø 24	1/3	A	C	ZP 44FS4PAC-	
			Ø 24	1/1	A	B - C	ZP 41-4PABC	
			Ø 24	1/2	A	B - C	ZP 43-4PABC	
			Ø 24	1/3	A	B - C	ZP 45-4PABC	
			Ø 24	1/3	A	B - C	ZP 45-4PABC	



DETERMINAZIONE DEL RINVIO DA IMPIEGARE

AVVERTENZE DATI TECNICI

Nella determinazione del rinvio da impiegare oltre alle esigenze puramente tecniche delle potenze in funzione del numero di giri e delle coppie da trasmettere, bisogna tenere conto della gravosità dell'impiego che dipende da molteplici fattori: Ciclo di funzionamento (intermittente, costante, ecc. ecc.), carichi radiali e assiali gravanti sulla estremità degli alberi, temperature max. e min., ambiente (polveroso ecc. ecc.) tipo di lubrificante.

- 1) Determinare il fattore di servizio FS indicato nella tabella 2.
- 2) Calcolare la potenza nominale $P_n = \text{Potenza effettiva } P_e \times F_s$.
- 3) Con la velocità in uscita e la potenza effettiva P_n scegliere a tab. 3 la dimensione ed il rapporto del rinvio da ordinare.
- 4) Controllare che i carichi radiali F_r e assiali F_a , applicati al centro della sporgenza di ogni singolo albero o al centro della cavità, non superino i valori riportati in Tabella 4.
- 5) Verificare che la temperatura di esercizio non superi i valori da $-20^\circ\text{C} \div +80^\circ\text{C}$.
- 6) Nel caso di rapporto 1/2 o 1/3 non usare il rinvio in moltiplicazione entrando oltre 750 giri/1' nel rapporto 1:2 e 500 giri/1' nel rapporto 1:3.
- 7) In presenza di ambienti particolarmente polverosi e conseguentemente abrasivi evitare l'esposizione diretta del paraolio onde preservarlo per consentire una durata maggiore dello stesso.

HOW TO SELECT THE CORRECT RIGHT-ANGLE BEVEL GEAR DRIVE FOR YOUR APPLICATION

TECHNICAL NOTES

Selecting the correct type of angle bevel gear is not simply a question of defining the power required in relation to R.P.M. and the torque to be transmitted. It also involves defining the conditions under which the angle bevel gear will be used. Defining operating conditions involves taking into consideration a number of factors such as the type of operating cycle (intermittent, continuous), radial and axial loads on the shaft ends, maximum and minimum temperatures, ambient conditions (e.g. dust and dirt levels) and the type of lubricant used. To decide the type and size of angle bevel gear required, proceed as follows.

- 1) Use Table 2 to define the Service Factor for your application.
- 2) Calculate the Rated Power (P_n);
 $P_n = P_e (\text{Horsepower}) \times F_S$.
- 3) On Table 3, use the output speed and the rated power (P_n) to select the angle gear size and transmission ratio required for your application.
- 4) Check that the radial F_r and axial F_a loads applied at the centre of the protrusion of every single shaft or at the centre of the hollow shaft does not exceed the values shown in table 4.
- 5) Check that the operating temperature does not exceed $-20^\circ\text{C} \div +80^\circ\text{C}$.
- 6) If you require a 1/2 or 1/3 ratio, do not use a speed multiplier with an input more than 750 R.P.M. and 500 R.P.M. in ratio 1/2 and 1/3, respectively.
- 7) If the unit is to be used in very dusty conditions, protect the oil seal against direct exposure to dust to prevent abrasive damage which might shorten the working life of the unit.

TABELLA
TABLE

2

FATTORE DI SERVIZIO
SERVICE FACTOR F_S



	ore di funzionamento al giorno hours of operation per day			
	3	8	12	24
carico uniforme / uniform load	0.7	0.9	1	1.3
carico con urti modesti / load with moderate shocks	0.9	1	1.3	1.8
carico con urti / load with shocks	1.3	1.6	1.8	2.3



TABELLA 3 TABLE		POTENZE APPLICABILI (Pn) Momento torcente max in uscita Mt (albero entrata contrassegnato A) APPLICABLE POWERS (Pn) Max output torque Mt (input shaft sign A)															
Giri in uscita Output round		50 rpm		100 rpm		200 rpm		400 rpm		800 rpm		1400 rpm		2000 rpm		3000 rpm	
Coppia in uscita Output torque		Mt	potenza power	Mt	potenza power	Mt	potenza power	Mt	potenza power	Mt	potenza power	Mt	potenza power	Mt	potenza power	Mt	potenza power
Modello Model	Rapp. Ratio	Nm	Kw	Nm	Kw	Nm	Kw	Nm	Kw	Nm	Kw	Nm	Kw	Nm	Kw	Nm	Kw
Dz 10 - Dz 11	R 1:1	4,7	0,02	3,9	0,04	3,3	0,07	2,8	0,12	2,3	0,19	2,0	0,30	1,8	0,39	1,7	0,53
Dz 600-61		7,6	0,04	6,4	0,07	5,4	0,11	4,5	0,19	3,8	0,32	3,3	0,49	3,0	0,63	2,7	0,86
Dz 150-01		8,0	0,04	6,8	0,07	5,7	0,12	4,8	0,20	4,0	0,34	3,5	0,51	3,2	0,67	2,9	0,91
Zp 10 - Zp 11		9,1	0,05	7,6	0,08	6,4	0,13	5,4	0,23	4,5	0,38	4,0	0,58	3,6	0,76	3,3	1,03
Dz 20 - Dz 21		16,5	0,09	13,9	0,15	11,7	0,24	9,8	0,41	8,2	0,69	7,2	1,05	6,6	1,37	5,9	1,86
Dz 200-01 - Dz 200-21 Dz 505-60 Dz 505-70 - Dz 201-01		27,5	0,14	23,1	0,24	19,4	0,41	16,3	0,68	13,7	1,15	12,0	1,75	10,9	2,29	9,9	3,10
Zp 211-3V Zp 211-4V		28,8	0,15	24,2	0,25	20,3	0,43	17,1	0,72	14,4	1,20	12,5	1,83	11,4	2,39	10,3	3,25
Zp 20 Zp 220-4V Zp 21 Zp 221-4V Dz 604-50		34,5	0,18	29,0	0,30	24,4	0,51	20,5	0,86	17,2	1,44	15,0	2,20	13,7	2,87	12,4	3,89
512-31		46,9	0,25	39,5	0,41	33,2	0,70	27,9	1,17	23,5	1,97	20,4	2,99	18,7	3,91	16,9	5,30
Dz 930-01 Dz 930-11		48,9	0,26	41,1	0,43	34,5	0,72	29,0	1,22	24,4	2,05	21,2	3,11	19,4	4,07	17,6	5,51
Dz 30 Dz 31 Dz 311		53,1	0,28	44,6	0,47	37,5	0,79	31,6	1,32	26,5	2,22	23,1	3,38	21,1	4,42	19,1	5,99
Zp 311		75,7	0,40	63,7	0,67	53,5	1,12	45,0	1,89	37,9	3,17	32,9	4,82	30,1	6,30	27,2	8,54
Dz 40 - Zp 30 Zp 40 - Dz 41 Zp 31 - Zp 41		87,3	0,46	73,4	0,77	61,8	1,29	51,9	2,17	43,7	3,66	38,0	5,56	34,7	7,27	31,4	9,86
Dz 50 - Dz 51		119,5	0,63	100,5	1,05	84,5	1,77	71,0	2,98	59,7	5,00	51,9	7,61	47,5	9,95	42,9	13,48
Dz 270		4229,5	22,14	3556,6	37,23	2990,7	62,62	2514,9	105,31	2114,7	177,11	1838,6	269,48	1681,8	352,13	1519,7	477,28
Dz 12 - Dz 13	R 1:2	4,0	0,02	3,4	0,04	2,8	0,06	2,4	0,10	2,0	0,17	1,7	0,26	1,6	0,33	1,4	0,45
Zp 12 - Zp 13		8,9	0,05	7,5	0,08	6,3	0,13	5,3	0,22	4,4	0,37	3,9	0,57	3,5	0,74	3,2	1,00
Dz 22 - Dz 23		14,6	0,08	12,3	0,13	10,3	0,22	8,7	0,36	7,3	0,61	6,3	0,93	5,8	1,21	5,2	1,65
Zp 213-3V Zp 213-4V		28,1	0,15	23,7	0,25	19,9	0,42	16,7	0,70	14,1	1,18	12,2	1,79	11,2	2,34	10,1	3,17
Zp 22 Zp 222-4V Zp 23 Zp 223-4V		33,8	0,18	28,5	0,30	23,9	0,50	20,1	0,84	16,9	1,42	14,7	2,16	13,5	2,82	12,2	3,82
Dz 32 - Dz 33		42,5	0,22	35,7	0,37	30,1	0,63	25,3	1,06	21,3	1,78	18,5	2,71	16,9	3,54	15,3	4,80
Zp 313		71,3	0,37	59,9	0,63	50,4	1,06	42,4	1,77	35,6	2,98	31,0	4,54	28,3	5,93	25,6	8,04
Dz 42 - Zp 32 Zp 42 - Dz 43 Zp 33 - Zp 43		82,3	0,43	69,2	0,72	58,2	1,22	48,9	2,05	41,1	3,44	35,8	5,24	32,7	6,85	29,6	9,28
Dz 52 - Dz 53		100,5	0,53	84,5	0,88	71,0	1,49	59,7	2,50	50,2	4,21	43,7	6,40	39,9	8,36	36,1	11,34
Zp 24 Zp 25 Zp 215-3V Zp 215-4V Zp 224-4V Zp 225-4V	R 1:3	27,5	0,14	23,1	0,24	19,4	0,41	16,3	0,68	13,7	1,15	12,0	1,75	10,9	2,29	9,9	3,10
Zp 34 Zp 35 Zp 315 Zp 44 Zp 45		63,4	0,33	53,3	0,56	44,9	0,94	37,7	1,58	31,7	2,66	27,6	4,04	25,2	5,28	22,8	7,16

VALORI NON PREFERENZIALI (Consultare ufficio tecnico) - NON PREFERENTIAL VALUES (please contact our technical dept.)



TABELLA 4 CARICHI ESTERNI APPLICABILI IN RELAZIONE ALLE VELOCITÀ Fr = forza radiale Fa = forza assiale
TABLE **4** *MAX RADIAL AND AXIAL LOAD RELATION R.P.M.* *Fr = radial load Fa = axila load*

Giri in uscita Output round		50 rpm		100 rpm		200 rpm		400 rpm		800 rpm		1400 rpm		2000 rpm		3000 rpm		
Carichi radiali - assiali Radial - axial load		Fr	Fa	Fr	Fa	Fr	Fa	Fr	Fa	Fr	Fa	Fr	Fa	Fr	Fa	Fr	Fa	
Modello Model	Rapp. Ratio	N	N	N	N	N	N	N	N	N	N	N	N	N	N	N	N	
Dz 10 - Dz 11	R 1:1	139	94	117	79	98	66	83	56	70	47	60	41	55	37	50	34	
Dz 600-61		183	148	154	124	129	105	109	88	91	74	80	64	73	59	66	53	
Dz 150-01		143	143	120	120	101	101	85	85	72	72	62	62	57	57	51	51	
Zp 10 - Zp 11		195	158	164	133	138	112	116	94	98	79	85	69	78	63	70	57	
Dz 20 - Dz 21		328	220	276	185	232	156	195	131	164	110	142	96	130	87	118	79	
Dz 200-01 - Dz 200-21 Dz 505-60 Dz 505-70 - Dz 201-01		617	412	519	346	436	291	367	245	309	206	268	179	245	164	222	148	
Zp 211-3V Zp 211-4V		430	348	361	293	304	246	256	207	215	174	187	151	171	139	154	125	
Zp 20 Zp 220-4V Zp 21 Zp 221-4V Dz 604-50		516	418	434	351	365	295	307	248	258	209	224	182	205	166	185	150	
512-31		512	362	431	304	362	256	305	215	256	181	223	157	204	144	184	130	
Dz 930-01 Dz 930-11		470	331	395	278	332	234	279	197	235	165	204	144	187	132	169	119	
Dz 30 Dz 31 Dz 311		684	458	575	385	484	324	407	273	342	229	297	199	272	182	246	165	
Zp 311		826	554	695	465	584	391	491	329	413	277	359	241	329	220	297	199	
Dz 40 - Zp 30 Zp 40 - Dz 41 Zp 31 - Zp 41		953	639	802	537	674	452	567	380	477	319	414	278	379	254	342	229	
Dz 50 - Dz 51		1102	736	927	619	779	520	655	438	551	368	479	320	438	293	396	264	
Dz 270		12837	10390	10795	8737	9077	7347	7633	6178	6419	5195	5581	4517	5105	4132	4613	3733	
Dz 12 - Dz 13		R 1:2	107	76	90	64	76	54	64	45	54	38	47	33	43	30	39	27
Zp 12 - Zp 13			182	110	153	93	129	78	108	66	91	55	79	48	73	44	66	40
Dz 22 - Dz 23			276	168	232	141	195	119	164	100	138	84	120	73	110	67	99	60
Zp 213-3V Zp 213-4V	370		263	311	221	262	186	220	157	185	132	161	114	147	105	133	95	
Zp 22 Zp 222-4V 23 Zp 223-4V	445		316	374	266	315	224	265	188	223	158	194	137	177	126	160	114	
Dz 32 - Dz 33	548		361	461	303	387	255	326	214	274	180	238	157	218	143	197	130	
Zp 313	696		422	585	355	492	299	414	251	348	211	303	184	277	168	250	152	
Dz 42 - Zp 32 Zp 42 - Dz 43 Zp 33 - Zp 43	803		483	675	406	568	341	478	287	402	241	349	210	319	192	289	173	
Dz 52 - Dz 53	927		562	779	473	655	397	551	334	463	281	403	244	369	223	333	202	
Zp 24 Zp 25 Zp 215-3V Zp 215-4V Zp 224-4V Zp 225-4V	R 1:3		357	199	301	167	253	141	213	118	179	99	155	86	142	79	128	71
Zp 34 Zp 35 Zp 315 Zp 44 Zp 45		619	346	521	291	438	245	368	206	310	173	269	151	246	138	222	124	

VALORI NON PREFERENZIALI (Consultare ufficio tecnico) - NON PREFERENTIAL VALUES (please contact our technical dept.)

trasmissioni



Serie / Series Dz



MOD.	DZ	Rapp.	Entrata	Uscita	Modello	Peso
MISURA SIZE	1	Ratio	In	Out	Model	Weight
FLANGE FLANGES	2	1/1	A	B	DZ 10S – 2FAB –	Kg 0.3
		1/1	A	C	DZ 10FS2FAC –	
		1/2	A	B	DZ 12S – 2FAB –	
		1/2	A	C	DZ 12FS2FAC –	
		1/1	A	B – C	DZ 11 – – 2FABC	
		1/2	A	B – C	DZ 13 – – 2FABC	

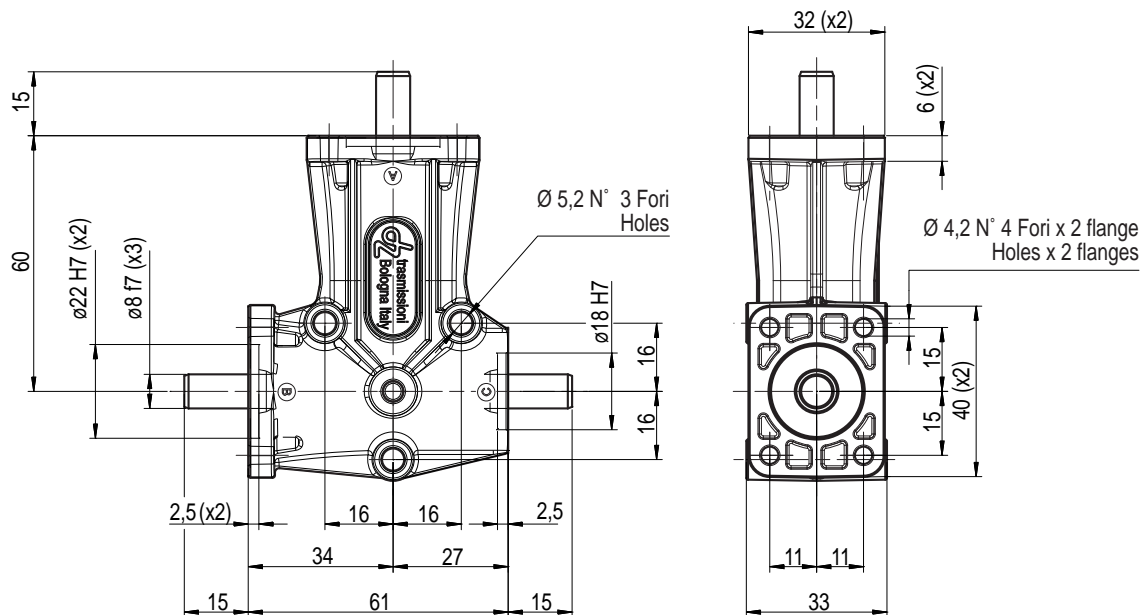
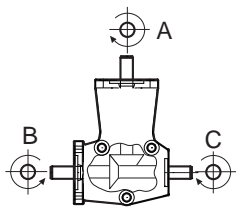

MOD.	DZ	Rapp.	Entrata	Uscita	Modello	Peso
MISURA SIZE	1	Ratio	In	Out	Model	Weight
FLANGE FLANGES	3	1/1	A	B	DZ 10S – 3FAB –	Kg 0.3
		1/1	A	C	DZ 10FS3FAC –	
		1/2	A	B	DZ 12S – 3 FAB –	
		1/2	A	C	DZ 12FS3FAC –	
		1/1	A	B – C	DZ 11 – – 3FABC	
		1/2	A	B – C	DZ 13 – – 3FABC	

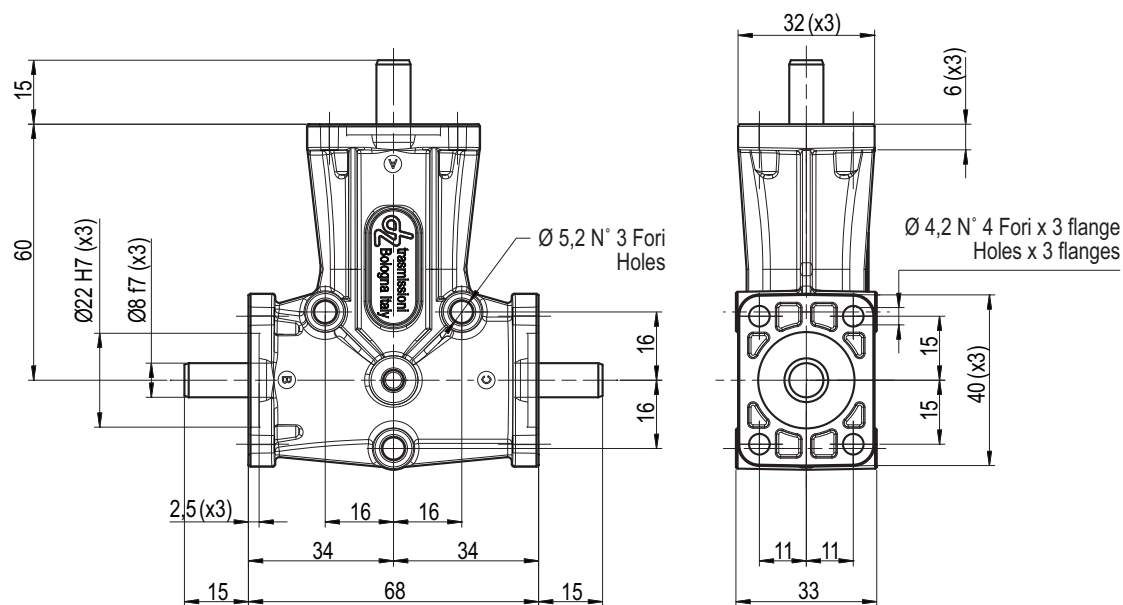
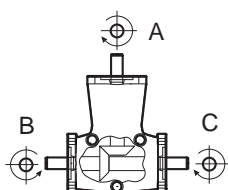

MOD.	DZ	Rapp.	Entrata	Uscita	Modello	Peso		
			Ratio	In	Out	Model	Weight	
MISURA SIZE	2	FLANGE FLANGES	2	1/1	A	B	DZ 20S-2FAB-	Kg 1.1
				1/1	A	C	DZ 20FS2FAC-	
				1/2	A	B	DZ 22S-2FAB-	
				1/2	A	C	DZ 22FS2FAC-	
1/1	A	B - C	DZ 21--2FABC	Kg 1.2				
			DZ 23--2FABC					

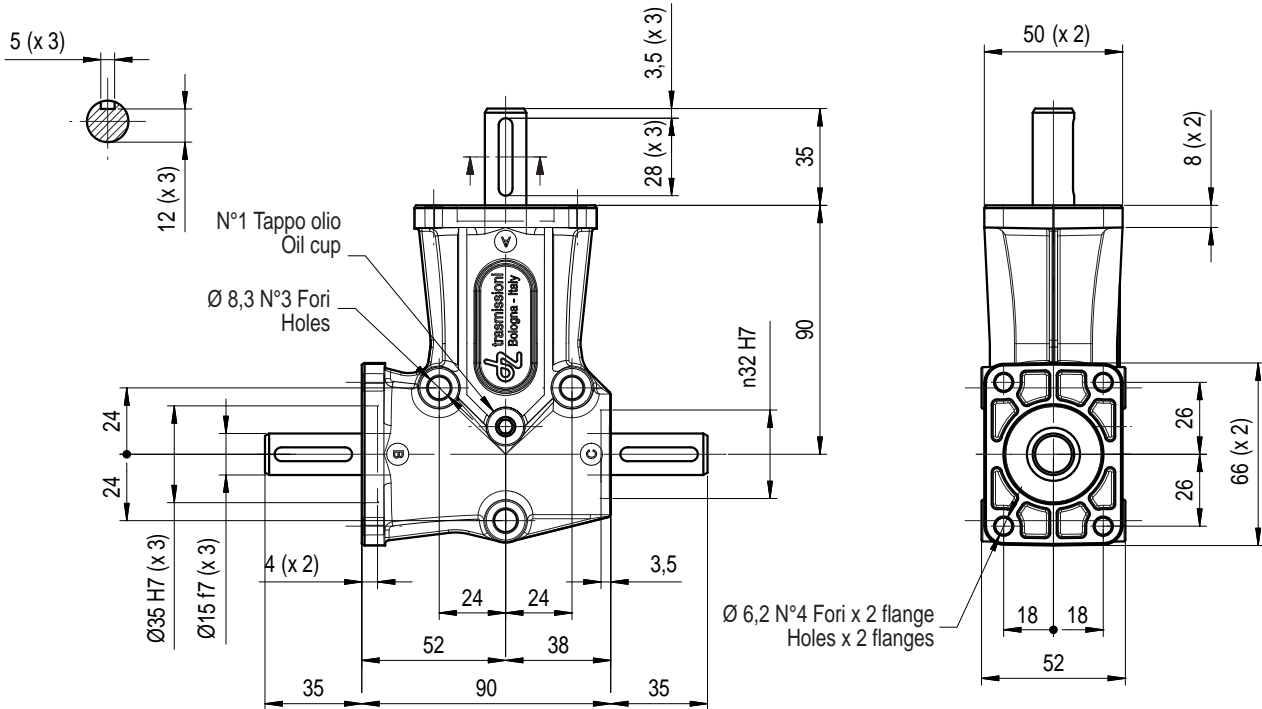
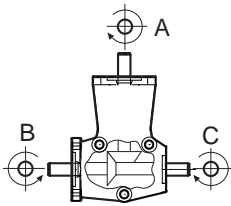

MOD.	DZ	Rapp.	Entrata	Uscita	Modello	Peso		
			Ratio	In	Out	Model	Weight	
MISURA SIZE	2	FLANGE FLANGES	3	1/1	A	B	DZ 20S-3FAB-	Kg 1.1
				1/1	A	C	DZ 20FS3FAC-	
				1/2	A	B	DZ 22S-3FAB-	
				1/2	A	C	DZ 22FS3FAC-	
1/1	A	B - C	DZ 21--3FABC	Kg 1.2				
			DZ 23--3FABC					

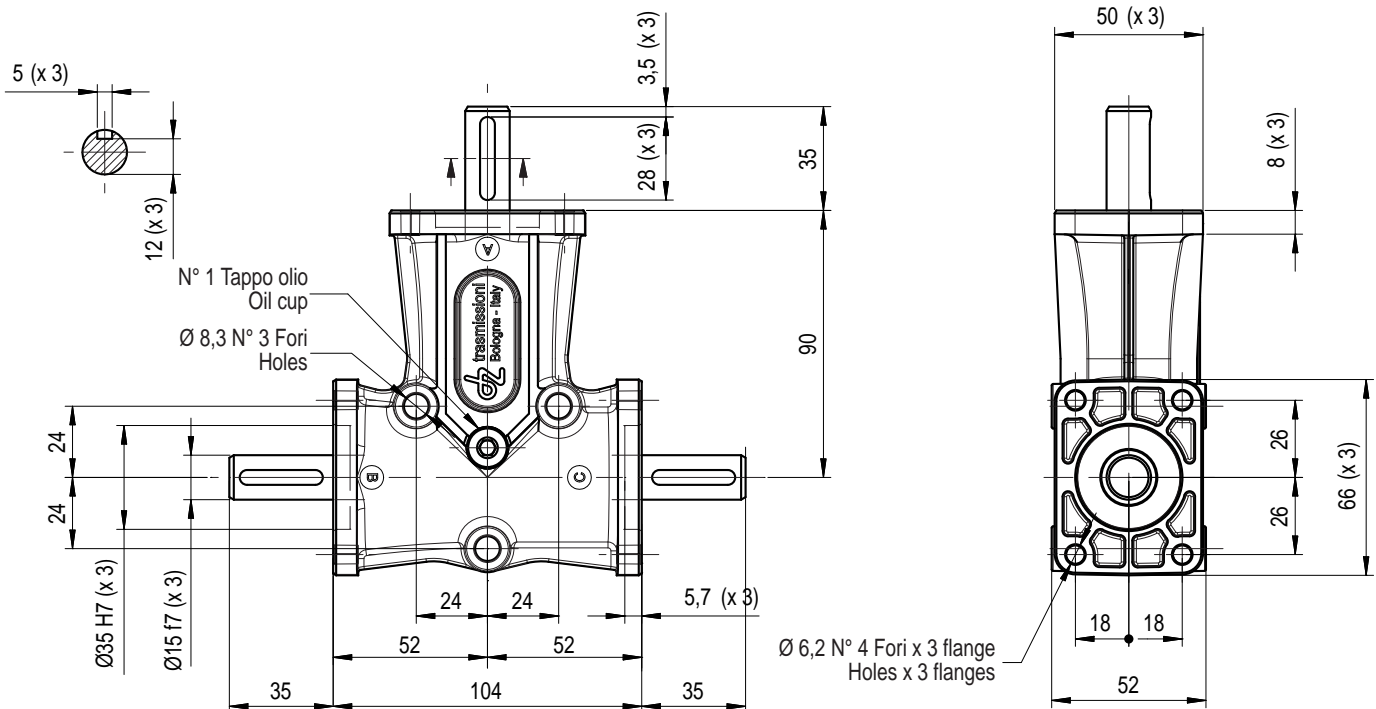
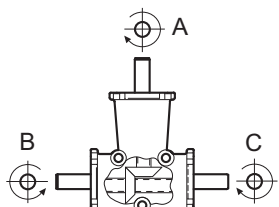



MOD.	DZ
MISURA SIZE	3
ALBERO CAVO HOLLOW SHAFT	

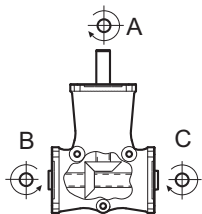

Rapp.	Entrata	Uscita	Modello	Peso
Ratio	In	Out	Model	Weight
1/1	A	B-C	DZ 311-3FABC	Kg 3.3

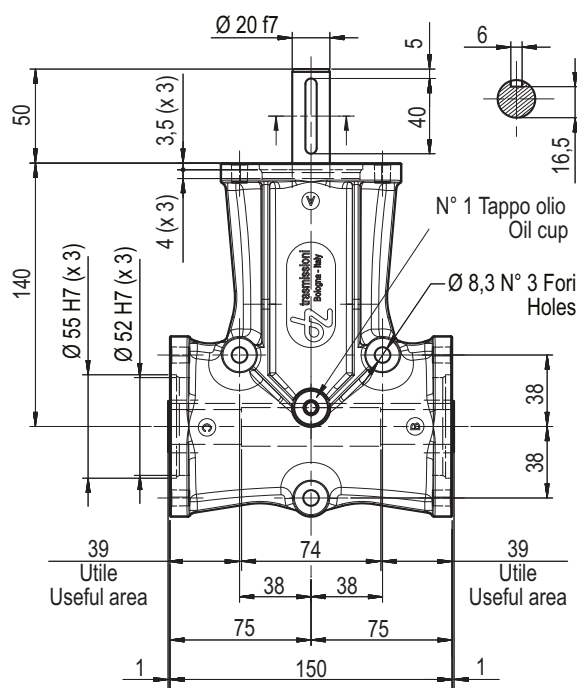
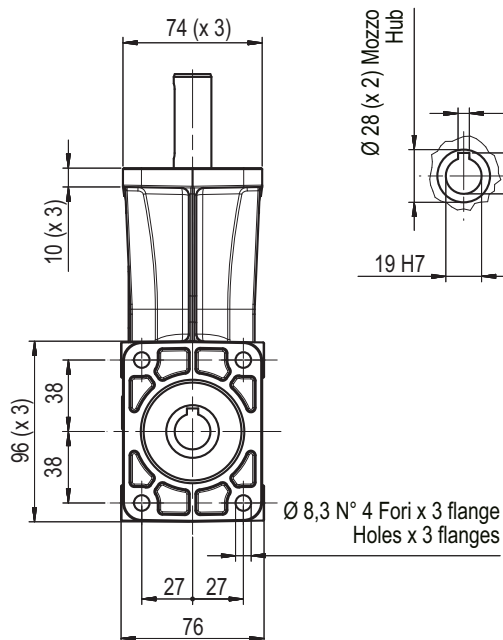

MOD.	DZ
MISURA SIZE	3

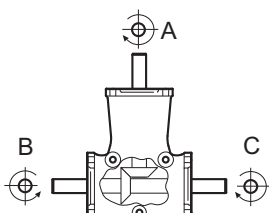

Rapp.	Entrata	Uscita	Modello	Peso
Ratio	In	Out	Model	Weight
1/1	A	B	DZ 30S-3FAB-	Kg 3.4
1/1	A	C	DZ 30FS3FAC-	
1/2	A	B	DZ 32S-3FAB-	
1/2	A	C	DZ 32FS3FAC-	
1/1	A	B-C	DZ 31--3FABC	Kg 3.5
1/2	A	B-C	DZ 33--3FABC	

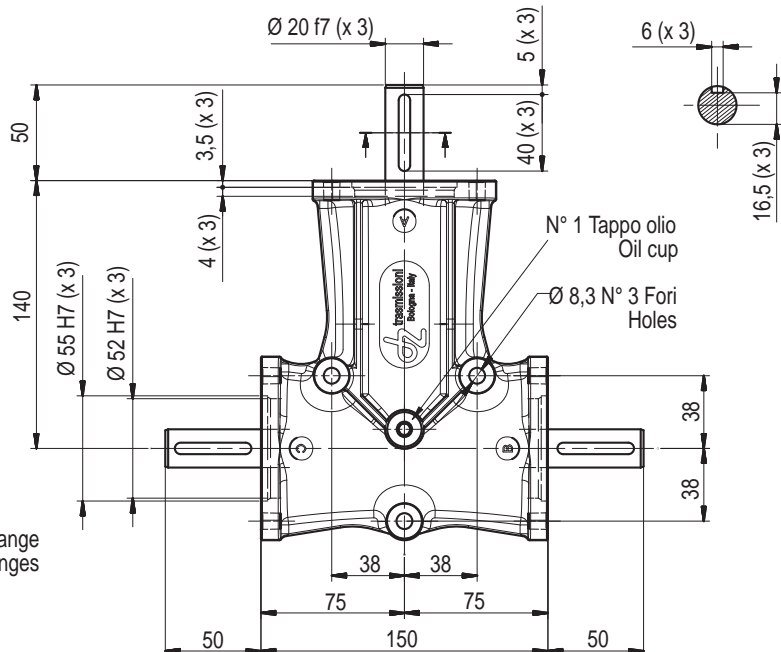
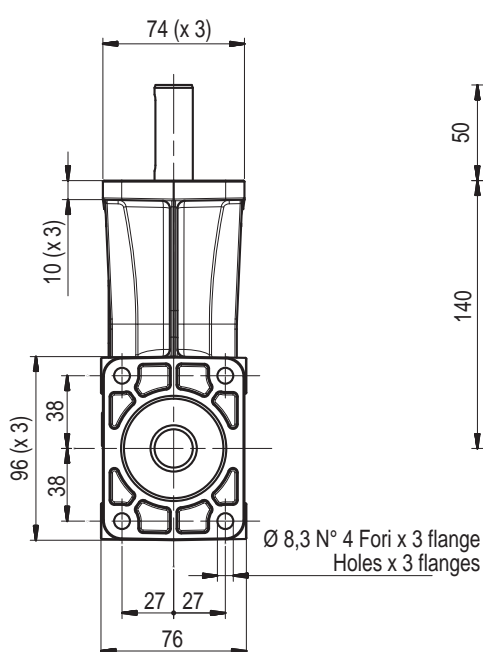

MOD.	DZ		Rapp.	Entrata	Uscita	Modello	Peso	
			Ratio	In	Out	Model	Weight	
MISURA SIZE	4		1/1	A	B	DZ 40S-3FAB-	Kg 5.5	
			1/1	A	C	DZ 40FS3FAC-		
			1/2	A	B	DZ 42S-3FAB-		
			1/2	A	C	DZ 42FS3FAC-		
			1/1	A	B - C	DZ 41--3FABC	Kg 5.8	
			1/2	A	B - C	DZ 43--3FABC		

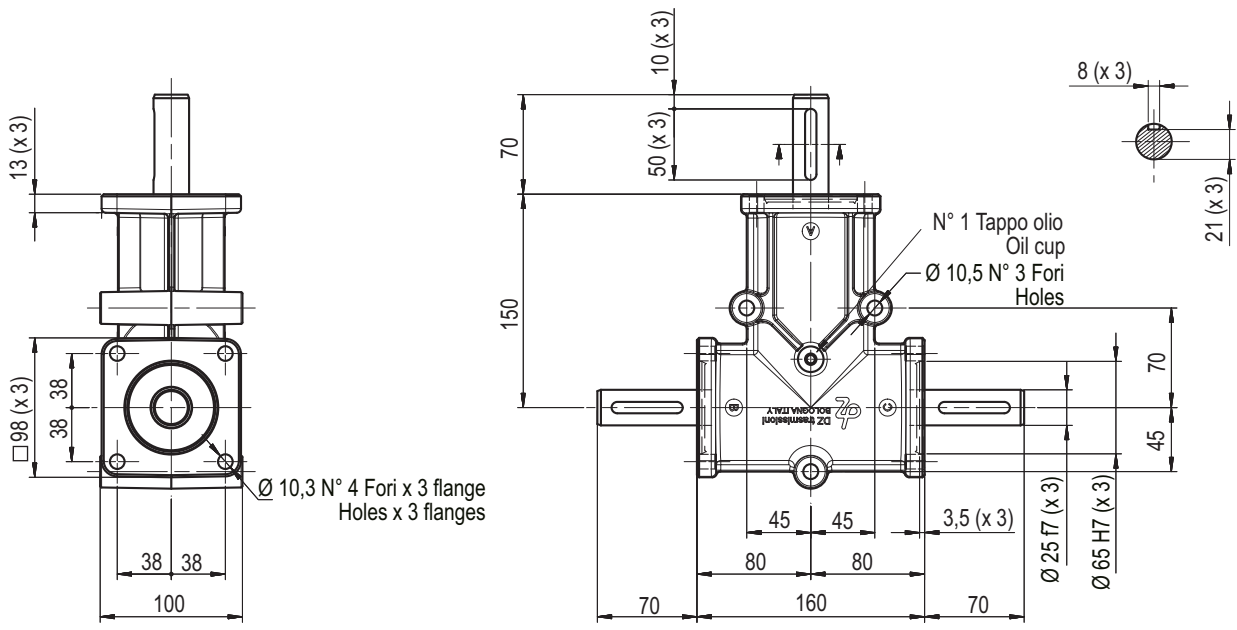

MOD.	DZ		Rapp.	Entrata	Uscita	Modello	Peso	
			Ratio	In	Out	Model	Weight	
MISURA SIZE	5		1/1	A	B	DZ 50S-3FAB-	Kg 8.1	
			1/1	A	C	DZ 50FS3FAC-		
			1/2	A	B	DZ 52S-3FAB-		
			1/2	A	C	DZ 52FS3FAC-		
			1/1	A	B - C	DZ 51--3FABC	Kg 8.8	
			1/2	A	B - C	DZ 53--3FABC		

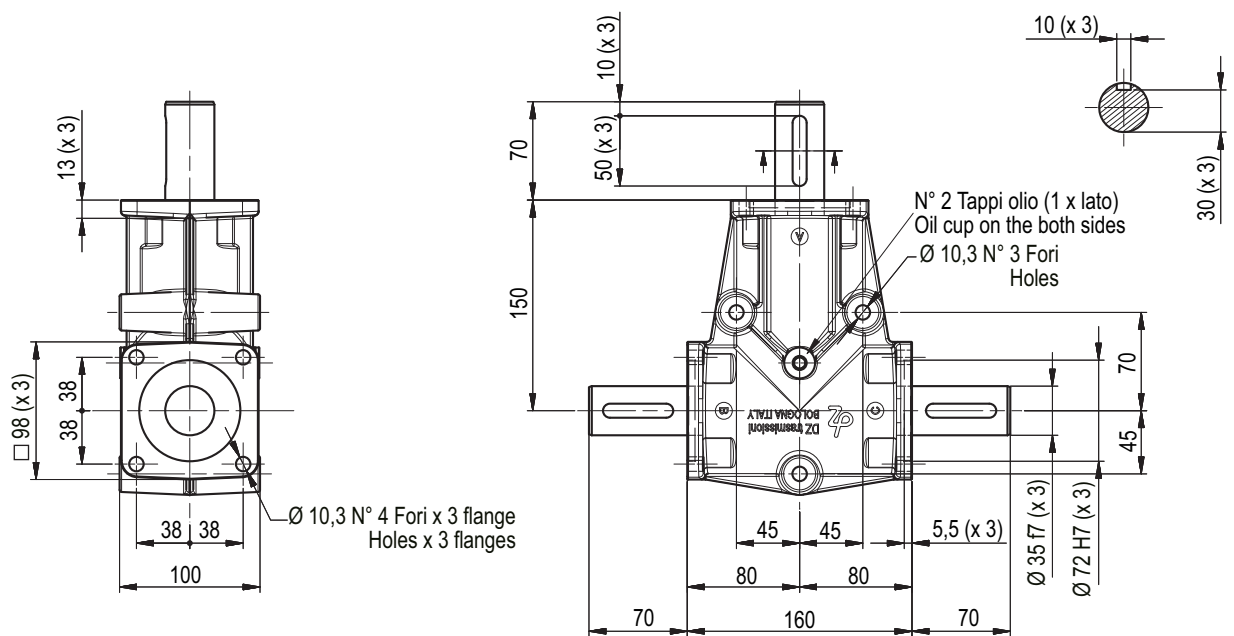



trasmissioni



Serie Inox / Inox Series Dz



MOD.	DZ		Rapp.	Entrata	Uscita	Modello	Peso
			Ratio	In	Out	Model	Weight
MISURA SIZE	2		1/1	A	B	DZ 20S-2FAB-INOX	Kg 1.25
			1/1	A	C	DZ 20FS2FAC-INOX	
			1/2	A	B	DZ 22S-2FAB-INOX	
			1/2	A	C	DZ 22FS2FAC-INOX	
FLANGE FLANGES	2		1/1	A	B - C	DZ 21--2FABC-INOX	Kg 1.35
			1/2	A	B - C	DZ 23--2FABC-INOX	

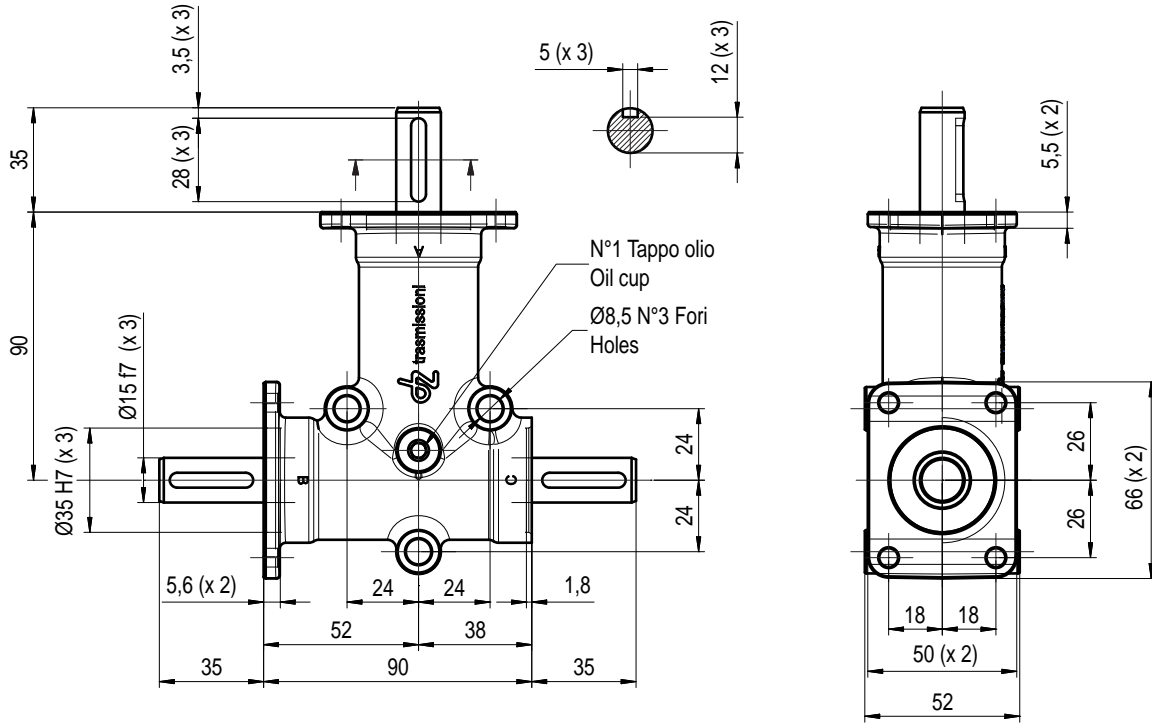

MOD.	DZ		Rapp.	Entrata	Uscita	Modello	Peso
			Ratio	In	Out	Model	Weight
MISURA SIZE	2		1/1	A	B	DZ 20S-3FAB-INOX	Kg 1.31
			1/1	A	C	DZ 20FS3FAC-INOX	
			1/2	A	B	DZ 22S-3FAB-INOX	
			1/2	A	C	DZ 22FS3FAC-INOX	
FLANGE FLANGES	3		1/1	A	B - C	DZ 21--3FABC-INOX	Kg 1.41
			1/2	A	B - C	DZ 23--3FABC-INOX	

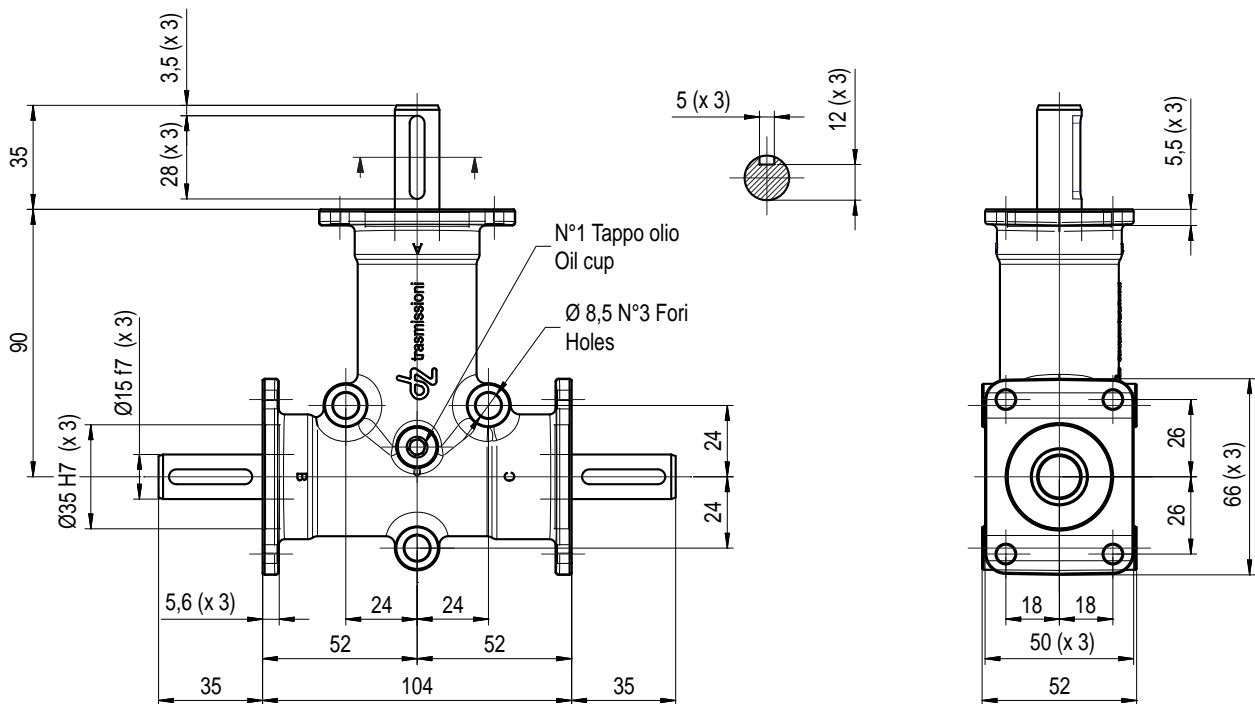

trasmissioni



Serie / Series Zp



MOD.	ZP	Rapp.	Entrata	Uscita	Modello	Peso
MISURA SIZE	1	Ratio	In	Out	Model	Weight
		1/1	A	B	ZP 10S-4PAB-	Kg 0.6
		1/1	A	C	ZP 10FS4PAC-	
		1/2	A	B	ZP 12S-4PAB-	
		1/2	A	C	ZP 12FS4PAC-	
		1/1	A	B - C	ZP 11--4PABC	
		1/2	A	B - C	ZP 13--4PABC	

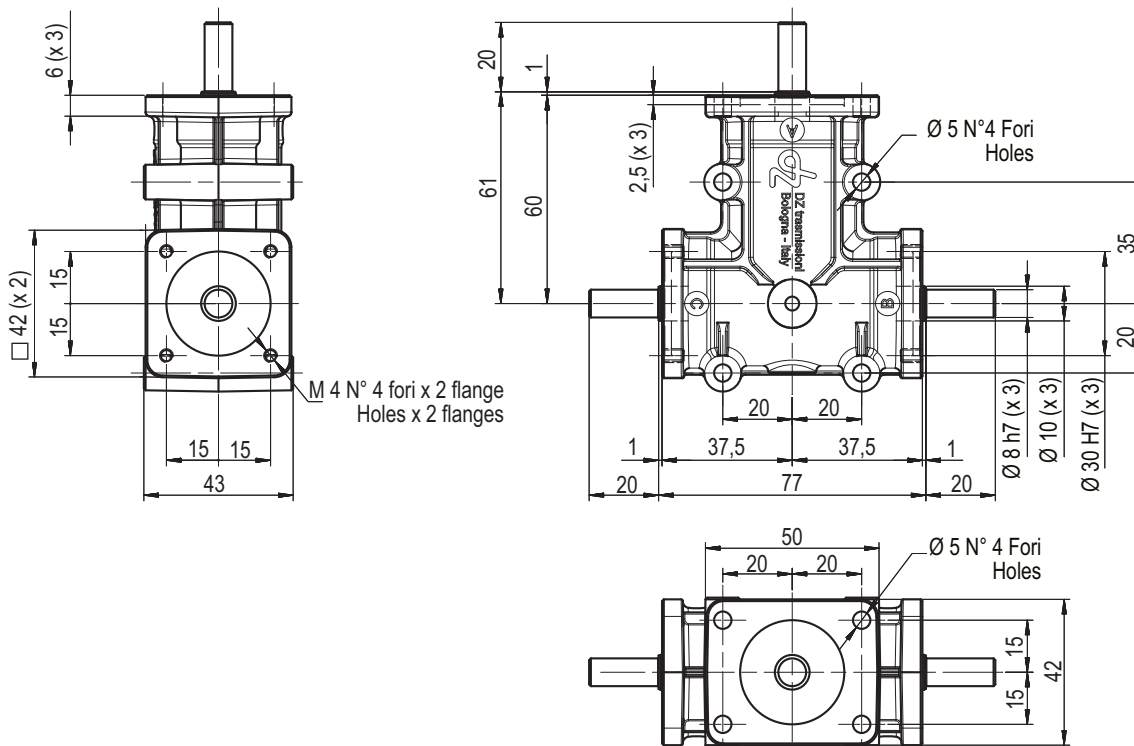
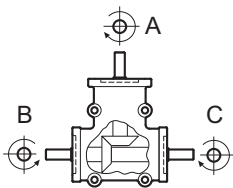

MOD.	ZP	Rapp.	Entrata	Uscita	Modello	Peso
MISURA SIZE	2	Ratio	In	Out	Model	Weight
		1/1	A	B	ZP 20S-4PAB-	Kg 2
		1/1	A	C	ZP 20FS4PAC-	
		1/2	A	B	ZP 22S-4PAB-	
		1/2	A	C	ZP 22FS4PAC-	
		1/3	A	B	ZP 24S-4PAB-	
		1/3	A	C	ZP 24FS4PAC-	
		1/1	A	B - C	ZP 21--4PABC	
		1/2	A	B - C	ZP 23--4PABC	
		1/3	A	B - C	ZP 25--4PABC	

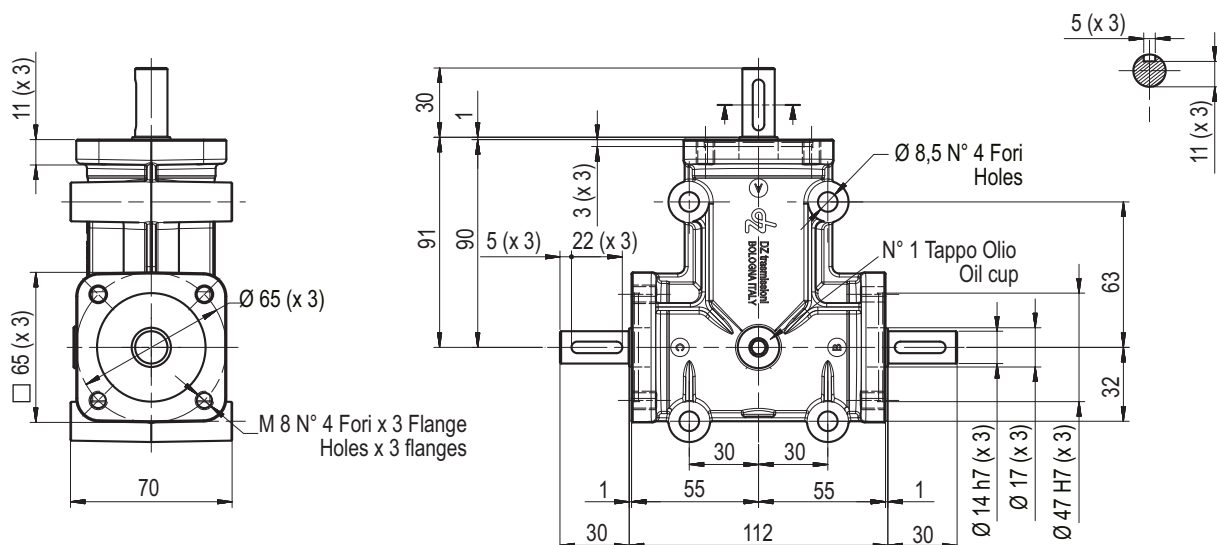
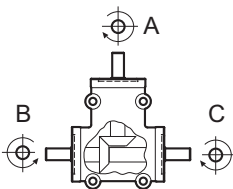

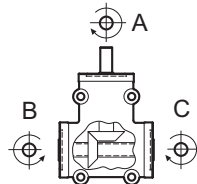
MOD.	ZP		Rapp.	Entrata	Uscita	Modello	Peso
			Ratio	In	Out	Model	Weight
MISURA SIZE	2		1/1	A	B - C	ZP 211-4P3V-	Kg 2
			1/2	A	B - C	ZP 213-4P3V-	
			1/3	A	B - C	ZP 215-4P3V-	

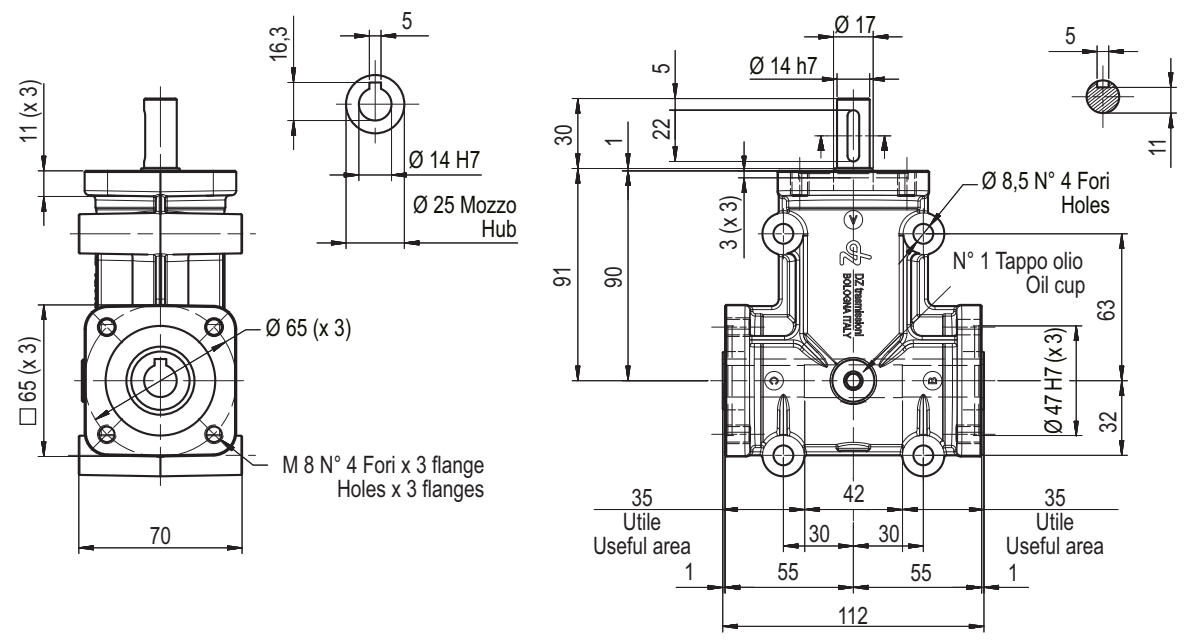

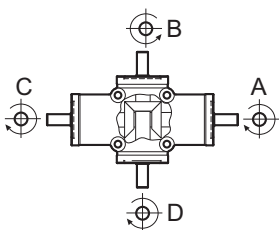
MOD.	ZP		Rapp.	Entrata	Uscita	Modello	Peso
			Ratio	In	Out	Model	Weight
MISURA SIZE	2		1/1	A	B - C	ZP 220S-4PABC	Kg 3.2
			1/1	A	C - D	ZP 220FS4PACD	
			1/2	A	B - C	ZP 222S-4PABC	
			1/2	A	C - D	ZP 222FS4PACD	
			1/3	A	B - C	ZP 224S-4PABC	
			1/3	A	C - D	ZP 224FS4PACD	
			1/1	A	B - C - D	ZP 221-4PABCD	
			1/2	A	B - C - D	ZP 223-4PABCD	
			1/3	A	B - C - D	ZP 225-4PABCD	

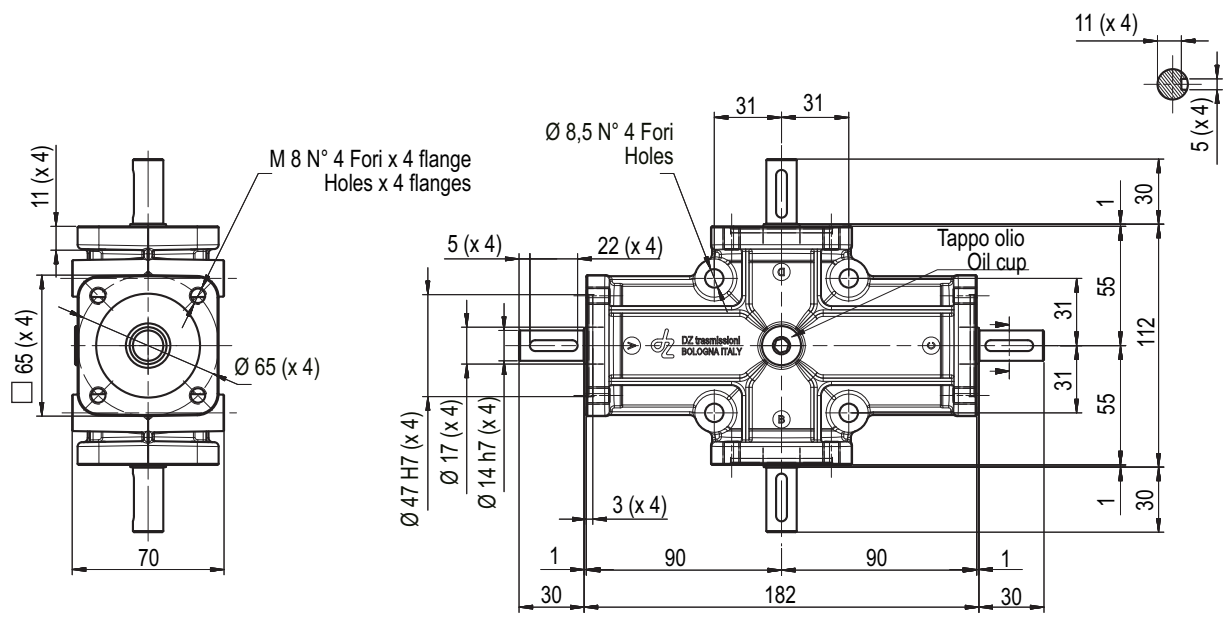



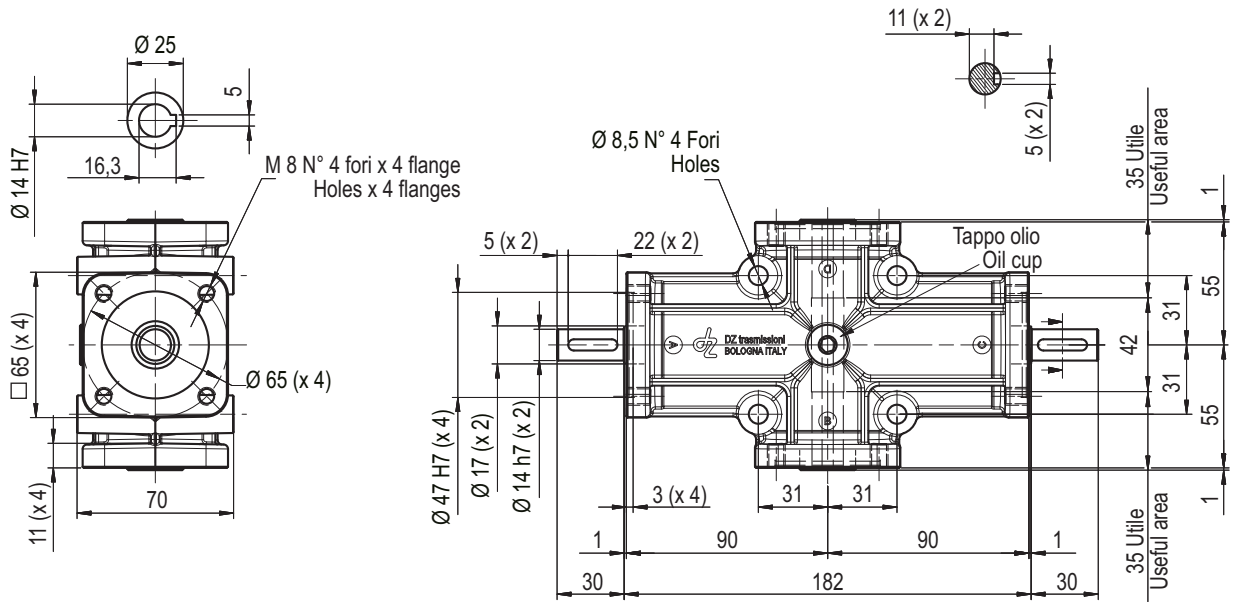

MOD.	ZP		Rapp.	Entrata	Uscita	Modello	Peso	
			Ratio	In	Out	Model	Weight	
MISURA SIZE	2		1/1	A	B - C - D	ZP 211-4P4V-	Kg 3	
			1/2	A	B - C - D	ZP 213-4P4V-		
			1/3	A	B - C - D	ZP 215-4P4V-		

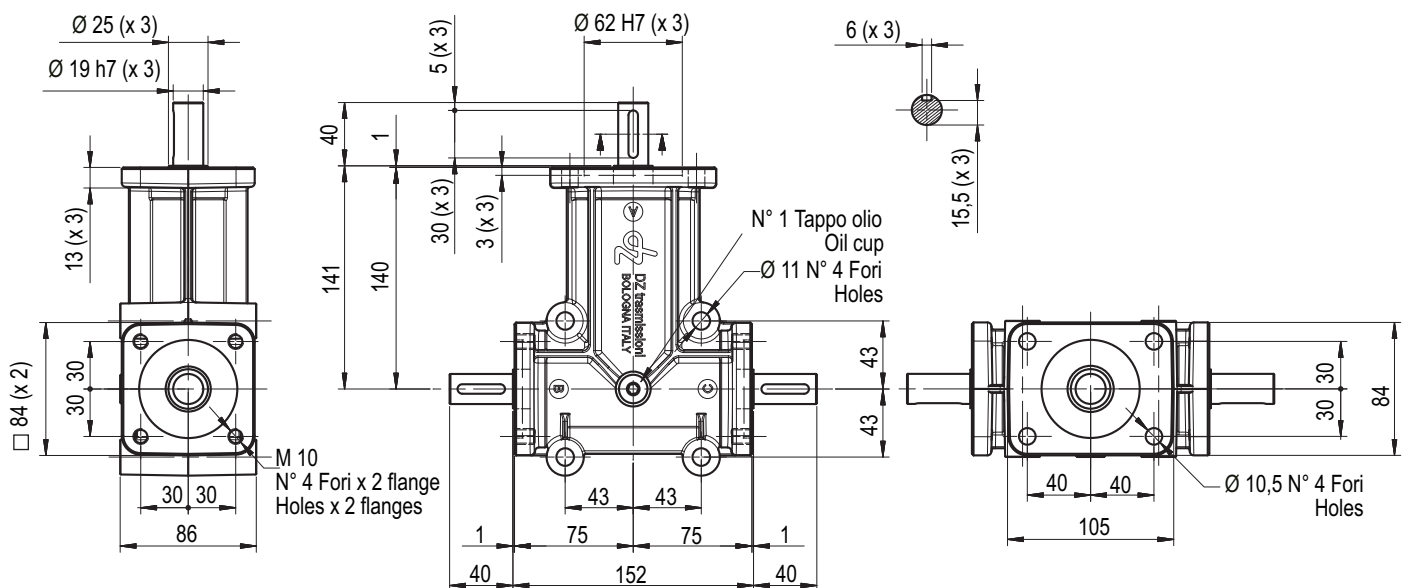

MOD.	ZP		Rapp.	Entrata	Uscita	Modello	Peso	
			Ratio	In	Out	Model	Weight	
MISURA SIZE	3		1/1	A	B	ZP 30S-4PAB-	Kg 4.5	
			1/1	A	C	ZP 30FS4PAC-		
			1/2	A	B	ZP 32S-4PAB-		
			1/2	A	C	ZP 32FS4PAC-		
			1/3	A	B	ZP 34S-4PAB-		
			1/3	A	C	ZP 34FS4PAC-		
			1/1	A	B - C	ZP 31--4PABC		
			1/2	A	B - C	ZP 33--4PABC		
			1/3	A	B - C	ZP 35--4PABC		



MOD.	ZP		Rapp.	Entrata	Uscita	Modello	Peso
MISURA SIZE	3		Ratio	In	Out	Model	Weight
INVERTITORE REVERSER							
			1/1	A	B	ZP 30 – INVERT	Kg 4.5
			1/1	A	B – C	ZP 31 – INVERT	

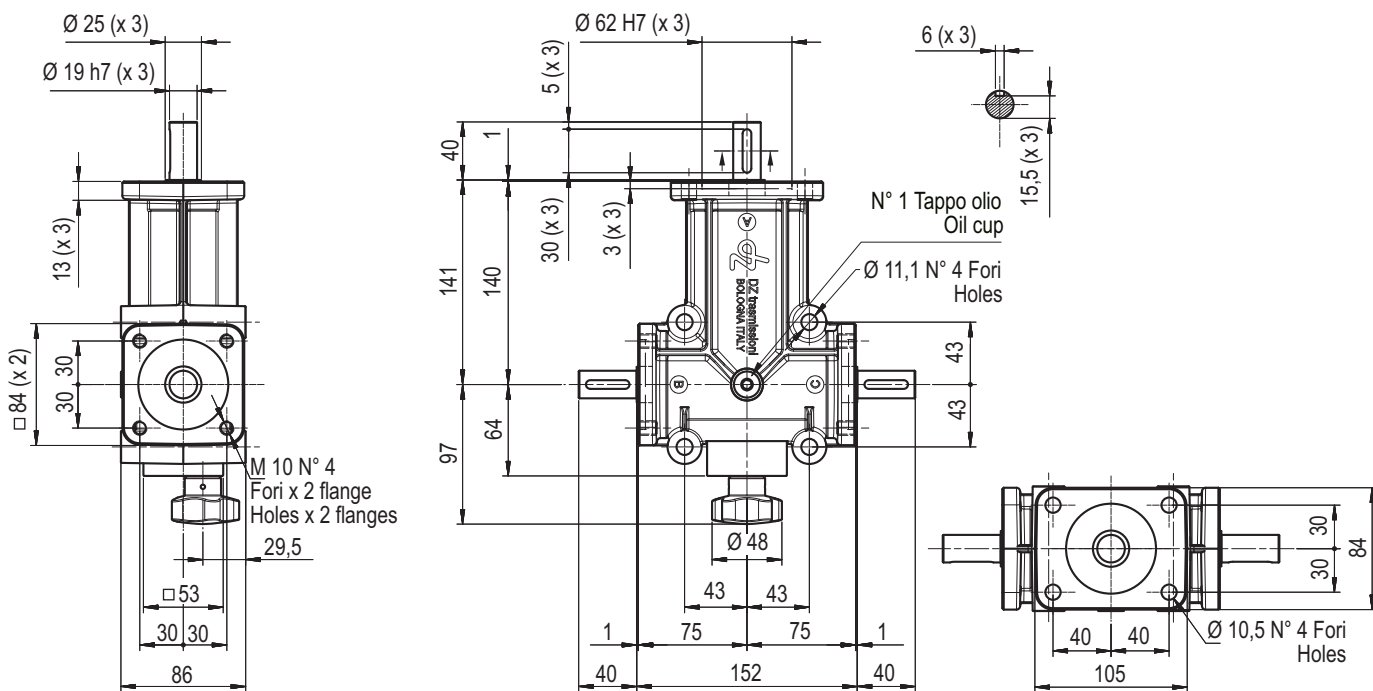

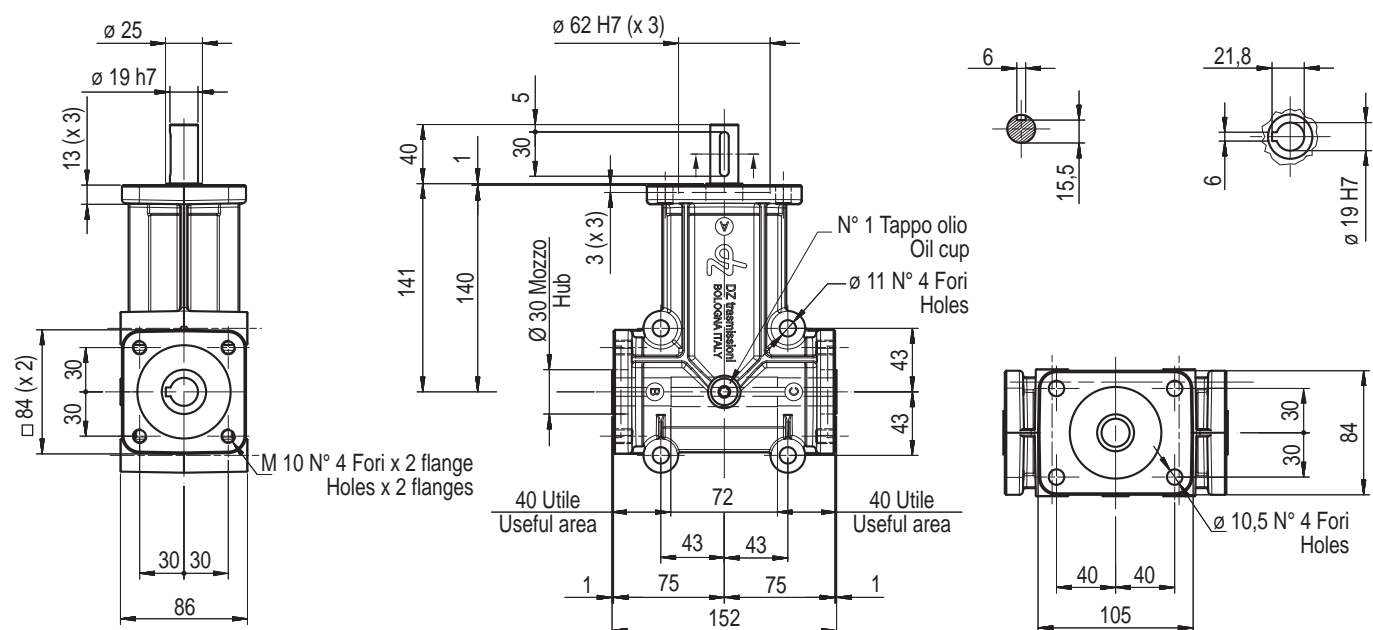

MOD.	ZP		Rapp.	Entrata	Uscita	Modello	Peso
MISURA SIZE	3		Ratio	In	Out	Model	Weight
			1/1	A	B – C	ZP 311 – 4P3V –	Kg 4.5
			1/2	A	B – C	ZP 313 – 4P3V –	
			1/3	A	B – C	ZP 315 – 4P3V –	



MOD.	ZP
MISURA SIZE	4

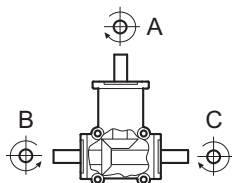

Rapp. Ratio	Entrata In	Uscita Out	Modello Model
1/1	A	B	ZP 40S-4PAB-
1/1	A	C	ZP 40FS4PAC-
1/2	A	B	ZP 42S-4PAB-
1/2	A	C	ZP 42FS4PAC-
1/3	A	B	ZP 44S-4PAB-
1/3	A	C	ZP 44FS4PAC-
1/1	A	B - C	ZP 41--4PABC
1/2	A	B - C	ZP 43--4PABC
1/3	A	B - C	ZP 45--4PABC

Peso
Weight

Kg 4.5

