

SKF Couplings

SKF®



SKF Flex Couplings

SKF Flex Couplings are designed to accommodate misalignment and shock loads and dampen vibration levels. These easy to install, maintenance-free couplings are available with either a machined-to-size or tapered bore.

Couplings with a tapered bore can be Face (F) mounted or Hub (H) mounted. The more versatile Reversible (R) design can be either face or hub mounted depending on the application. These couplings are also available with a taper bushing.

SKF Flex Couplings consist of 2 flanges and 1 tyre. The flanges are phosphate coated for improved corrosion resistance. The addition of a standard sized spacer flange can be used to accommodate applications where it is advantageous to move either shaft axially without disturbing either driving or driven machines.

SKF Flex tyres are available in natural rubber compounds for applications ranging from -50 to $+50$ °C. Chloroprene rubber compounds should be used in applications where exposure to greases and oils are likely. These compounds can accommodate temperatures ranging from -15 to $+70$ °C. The chloroprene tyres should be used where fire-resistance and anti-static (F.R.A.S.) properties are required.

Selection

1 Service factor

Determine the required service factor from **tables 9 and 10** on **pages 87 and 88**.

2 Design power

Multiply the normal running power by the service factor. This gives the design power for coupling selection.

3 Coupling size

Using the data from **table 1** on **page 61**, find the speed rating for a coupling that has a power that is greater than the design power. The required SKF Flex coupling is listed at the head of the column.

4 Bore size

Using product tables on **page 65 and 68**, check if the chosen flanges can accommodate both the driving and driven shafts.

Example

A SKF Flex coupling is required to transmit 30 kW from an electric motor running at 1 440 r/min to a centrifugal pump for 14 hours per day. The diameter of the motor shaft is 30 mm. The diameter of the pump shaft is 25 mm. A tapered bore is required.

1 Service factor

The appropriate service factor is 1. See **tables 9 and 10** on **pages 87 and 88**.

2 Design power

Design power = $30 \times 1 = 30$ kW

3 Coupling size

By searching for 1 440 r/min in **table 1** on **page 61**, the first power figure to exceed the required 30 kW in step (2) is 37,70 kW. The size of the coupling is 70.

4 Bore size

By referring to product tables on **page 65 and 68**, it can be seen that both shaft diameters fall within the bore range available. Please note that for this coupling the bore sizes for the Face and Hub design are different.

Table 1

Power ratings (kW)

Speed	Coupling size														
	40	50	60	70	80	90	100	110	120	140	160	180	200	220	250
r/min	kW														
50	0,13	0,35	0,66	1,31	1,96	2,62	3,53	4,58	6,96	12,17	19,74	32,83	48,82	60,73	76,83
100	0,25	0,69	1,33	2,62	3,93	5,24	7,07	9,16	13,93	24,35	39,48	65,65	97,64	121,47	153,66
200	0,50	1,38	2,66	5,24	7,85	10,47	14,14	18,32	27,85	48,69	78,95	131,31	195,29	242,93	307,33
300	0,75	2,07	3,99	7,85	11,78	15,71	21,20	27,49	41,78	73,04	118,43	196,96	292,93	364,40	460,99
400	1,01	2,76	5,32	10,47	15,71	20,94	28,27	36,65	55,71	97,38	157,91	262,62	390,58	485,86	614,66
500	1,26	3,46	6,65	13,09	19,63	26,18	35,34	45,81	69,63	121,73	197,38	328,27	488,22	607,33	768,32
600	1,51	4,15	7,98	15,71	23,56	31,41	42,41	54,97	83,56	146,07	236,86	393,93	585,86	728,80	921,99
700	1,76	4,84	9,31	18,32	27,49	36,65	49,48	64,14	97,49	170,42	276,34	459,58	683,51	850,26	1 075,65
720	1,81	4,98	9,57	18,85	28,27	37,70	50,89	65,97	100,27	175,29	284,23	472,71	703,04	874,55	1 106,39
800	2,01	5,53	10,64	20,94	31,41	41,88	56,54	73,30	111,41	194,76	315,81	525,24	781,15	971,73	1 229,32
900	2,26	6,22	11,97	23,56	35,34	47,12	63,61	82,46	125,34	219,11	355,29	590,89	878,80	1 093,19	1 382,98
960	2,41	6,63	12,77	25,13	37,70	50,26	67,85	87,96	133,70	233,72	378,97	630,28	937,38	1 166,07	1 475,18
1 000	2,51	6,91	13,30	26,18	39,27	52,36	70,68	91,62	139,27	243,46	394,76	656,54	976,44	1 214,66	1 536,65
1 200	3,02	8,29	15,96	31,41	47,12	62,83	84,82	109,95	167,12	292,15	473,72	787,85	1 171,73	–	–
1 400	3,52	9,68	18,62	36,65	54,97	73,30	98,95	128,27	194,97	340,84	552,67	919,16	–	–	–
1 440	3,62	9,95	19,15	37,70	56,54	75,39	101,78	131,94	200,54	350,58	568,46	945,42	–	–	–
1 600	4,02	11,06	21,28	41,88	62,83	83,77	113,09	146,60	222,83	389,53	631,62	–	–	–	–
1 800	4,52	12,44	23,94	47,12	70,68	94,24	127,23	164,92	250,68	438,22	–	–	–	–	–
2 000	5,03	13,82	26,60	52,36	78,53	104,71	141,36	183,25	278,53	–	–	–	–	–	–
2 200	5,53	15,20	29,26	57,59	86,39	115,18	155,50	201,57	–	–	–	–	–	–	–
2 400	6,03	16,59	31,92	62,83	94,24	125,65	169,63	–	–	–	–	–	–	–	–
2 600	6,53	17,97	34,58	68,06	102,09	136,13	183,77	–	–	–	–	–	–	–	–
2 800	7,04	19,35	37,24	73,30	109,95	146,60	–	–	–	–	–	–	–	–	–
2 880	7,24	19,90	38,30	75,39	113,09	150,79	–	–	–	–	–	–	–	–	–
3 000	7,54	20,73	39,90	78,53	117,80	157,07	–	–	–	–	–	–	–	–	–
3 600	9,05	24,88	47,87	94,24	–	–	–	–	–	–	–	–	–	–	–
Nominal torque (Nm)	24	66	127	250	375	500	675	875	1 330	2 325	3 770	6 270	9 325	11 600	14 675
Max torque (Nm)	64	160	318	487	759	1 096	1 517	2 137	3 547	5 642	9 339	16 455	23 508	33 125	42 740

Table 2

Assembled coupling characteristics

Coupling size	Speed	Mass tyre	Inertia	Torsional stiffness	Misalignment			Nominal torque	Torque	Screw size	Clamping screw torque
	Max.				Angular	Parallel	Axial		Max.		
–	r/min	kg	kg/m ²	Nm/°	°	mm		Nm	–	Nm	
40	4 500	0,1	0,00074	5	4	1,1	1,3	24	64	M6	15
50	4 500	0,3	0,00115	13	4	1,3	1,7	66	160	M6	15
60	4 000	0,5	0,0052	26	4	1,6	2,0	127	318	M6	15
70	3 600	0,7	0,009	41	4	1,9	2,3	250	487	M8	24
80	3 100	1,0	0,017	63	4	2,1	2,6	375	759	M8	24
90	3 000	1,1	0,031	91	4	2,4	3,0	500	1 096	M10	40
100	2 600	1,1	0,054	126	4	2,6	3,3	675	1 517	M10	40
110	2 300	1,4	0,078	178	4	2,9	3,7	875	2 137	M10	40
120	2 050	2,3	0,013	296	4	3,2	4,0	1 330	3 547	M12	50
140	1 800	2,6	0,255	470	4	3,7	4,6	2 325	5 642	M12	55
160	1 600	3,4	0,380	778	4	4,2	5,3	3 770	9 339	M16	80
180	1 500	7,7	0,847	1 371	4	4,8	6,0	6 270	16 455	M16	105
200	1 300	8,0	1,281	1 959	4	5,3	6,6	9 325	23 508	M16	120
220	1 100	10,0	2,104	2 760	4	5,8	7,3	11 600	33 125	M20	165
250	1 000	15,0	3,505	3 562	4	6,6	8,2	14 675	42 740	M20	165

Engineering data

Power ratings

Maximum torque figures should be treated as short duration overload ratings occurring in circumstances such as direct-on-line starting.

For speeds not shown, calculate the nominal torque for the design application using the formula below and select a coupling based on the nominal torque ratings.

$$\text{Nominal torque (Nm)} = \frac{\text{Design power (kW)} \times 9\,550}{\text{r/min}}$$

For additional information about SKF Flex Couplings, see **table 1** and **2** on **page 61**.

Order data

A complete SKF Flex coupling consists of:
2 flanges and 1 tyre.

For additional information about ordering a coupling see **table 3**.

Table 3

Order data										
Coupling type	Flanges	Qty	Element	Qty	Coupling bushing number	Qty	Spacer flange and shaft ¹⁾	Qty	Spacer bushing number	Qty
RSB both sides	PHE F70RSBFLG	2	PHE F70NRTYRE	1	–	–	–	–	–	–
RSB/F combination	PHE F70RSBFLG	1	PHE F70NRTYRE or	1	–	–	–	–	–	–
	PHE F70FTBFLG	1	PHE F70FRTYRE	–	PHF TB2012X...MM	1	PHE SM25-...DBSE	1	PHF 2517X...MM	1
RSB/H combination	PHE F70RSBFLG	1	PHE F70NRTYRE or	1	–	–	–	–	–	–
	PHE F70HTBFLG	1	PHE F70FRTYRE	–	PHF TB1610X...MM	1	PHE SM25-...DBSE	1	PHF 2517X...MM	1
F/F Combination	PHE F70FTBFLG	1	PHE F70NRTYRE or	1	PHF TB2012X...MM	1	PHE SM25-...DBSE	1	PHF 2517X...MM	1
	PHE F70FTBFLG	1	PHE F70FRTYRE	–	PHF TB2012X...MM	1	–	–	–	–
H/H Combination	PHE F70HTBFLG	1	PHE F70NRTYRE or	1	PHF TB1610X...MM	1	PHE SM25-...DBSE	1	PHF 2517X...MM	1
	PHE F70HTBFLG	1	PHE F70FRTYRE	–	PHF TB1610X...MM	1	–	–	–	–
F/H Combination	PHE F70FTBFLG	1	PHE F70NRTYRE or	1	PHF TB1610X...MM	1	PHE SM25-...DBSE	1	PHF 2517X...MM	1
	PHE F70HTBFLG	1	PHE F70FRTYRE	–	PHF TB2012X...MM	1	–	–	–	–
Reversible	PHE F70RTBFLG	2	PHE F70NRTYRE	1	PHF TB1610X...MM	2	–	–	–	–

¹⁾ To complete designation add distance between shaft ends. PHE SM25-100DBSE.

An SKF Flex coupling consists of 2 flanges and 1 tyre. An SKF Flex Spacer Coupling consists of 2 flanges, 1 tyre and 1 spacer (spacer part number consists of spacer shaft and rigid flange).

Installation

- 1 All metal components should be cleaned. Be sure to remove the protective coating on the flange bores. The taper bushings should be placed into the flanges and the screws lightly tightened.
- 2 If internal clamping rings are being used (size 40–60), position them onto the shaft (→ **fig. 1**). Place the flanges next to the clamping ring on each shaft and position them so that dimension M is obtained between the flange faces (→ **table 4, page 64**).
Where taper bushings are used, see separate fitting instructions supplied with the taper bushings.
Flanges with external clamping rings (sizes 70–250) should have the clamping rings fitted when installing, engaging only two or three of the threads of each screw at this time. These flanges should be positioned so that M is obtained by measuring the gap between the flange faces.
- 3 If shaft end float is to occur, locate the shafts at mid-position of end float when checking dimension M. Note that shaft ends may project beyond the faces of the flanges if required. In these cases, allow sufficient space between shaft ends for end float and misalignment.
- 4 Parallel alignment should be checked by placing a straight edge across the flanges at various points around the circumference (→ **fig. 3**). Angular alignment is checked by measuring the gap between the flanges at several positions around the circumference. Align the coupling as accurately as possible, particularly on high-speed applications.
- 5 Spread the tyre side walls apart and fit over the coupling flanges, making sure that the tyre beads seat properly on the flanges and clamping rings. To make sure that the tyre sits properly in position, it may be necessary to strike the outside diameter of the tyre with a small mallet (→ **fig. 4**). When the tyre is correctly positioned there, should be a gap between the ends of the tyre as shown in **table 5** on **page 64** (→ **fig. 5**).

- 6 Tighten clamping ring screws (→ **fig. 6**) alternately and evenly (half turn at a time), working round each flange until the required screw torque is achieved (→ **table 4, page 64**).

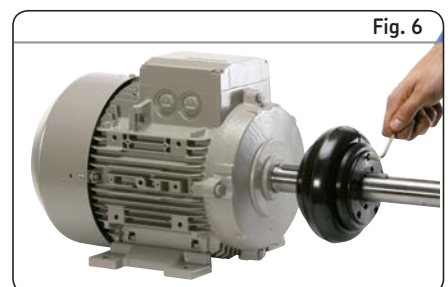
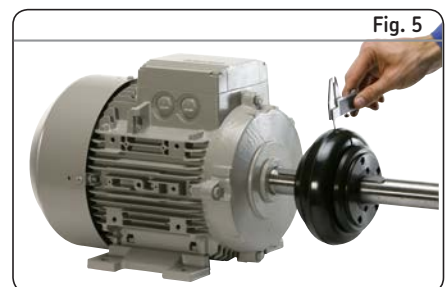
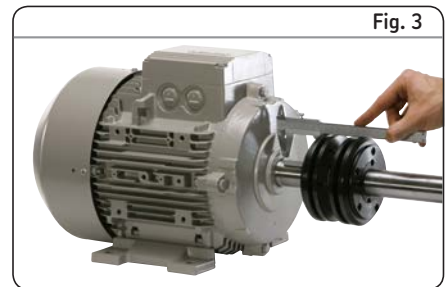
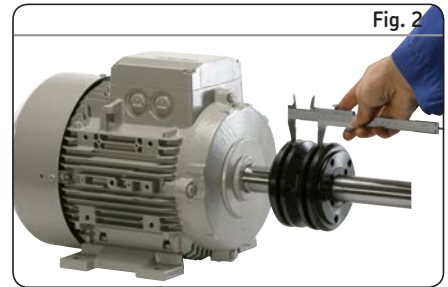
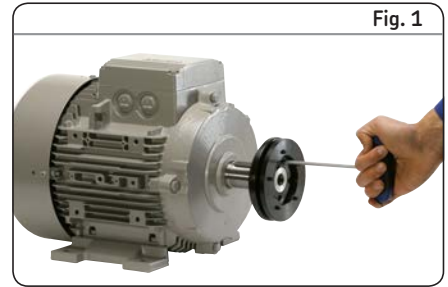

Table 4

SKF Flex coupling assembly data

Coupling size	M size	Screw size	Clamping screw torque
–	mm	–	Nm
F40 ¹⁾	22	M6	15
F50 ¹⁾	25	M6	15
F60 ¹⁾	33	M6	15
F70	23	M8	24
F80	25	M8	24
F90	27	M10	40
F100	27	M10	40
F110	25	M10	40
F120	29	M12	50
F140	32	M12	55
F160	30	M16	80
F180	46	M16	105
F200	48	M16	120
F220	55	M20	165
F250	59	M20	165

Hexagon socket caphead clamping screws on these sizes

Table 5

SKF Flex coupling tyre gap

Coupling size	Tyre gap
–	mm
F40 to F60	2
F70 to F120	3
F140 and F160	5
F180 to F250	6

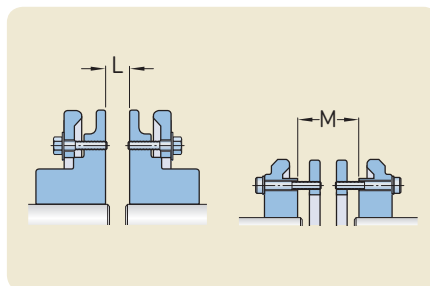

SKF Flex flanges types B, F and H

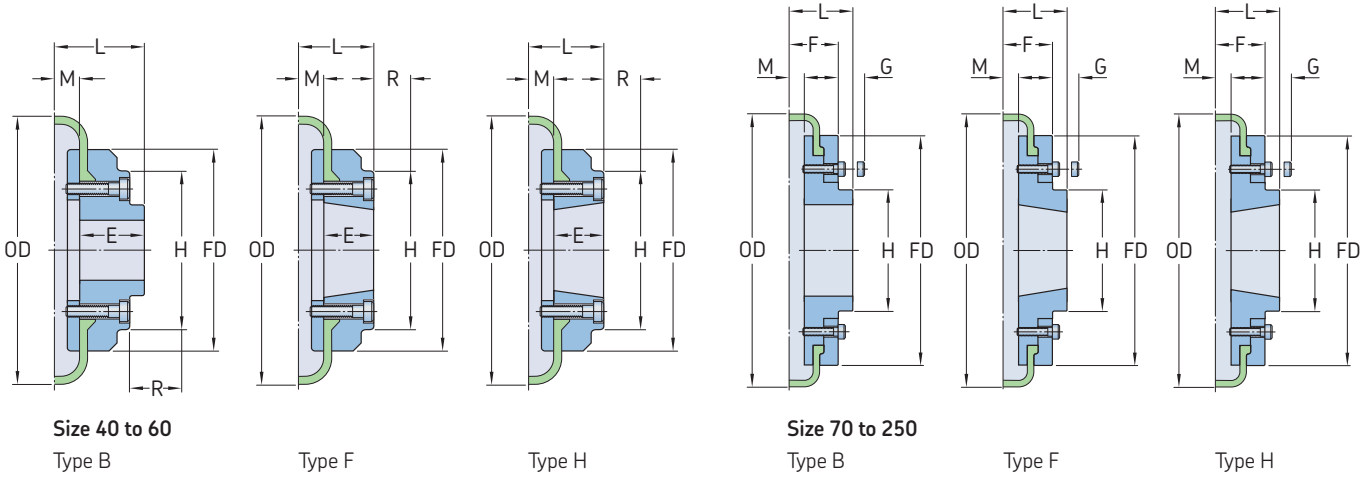

Size	Type	Bushing number	Dimensions Bore		Types F and H		Type B		Key screw	OD	FD	H	F	R ¹⁾	G ²⁾	M	Mass	Inertia	Designation	Tyre designation Natural	F.R.A.S
			Min.	Max.	L	E	L	E													
mm	-	-	mm		mm		mm										kg	kg/m ²	-		
40	B	-	9	30	-	-	33,0	22	M5	104	82	-	-	29	-	11,0	0,80	0,00074	PHE F40RSBFLG	PHE F40NRTYRE	PHE F40FRTYRE
40	F	1008	9	25	33,0	22	-	-	-	104	82	-	-	29	-	11,0	0,80	0,00074	PHE F40FTBFLG	PHE F40NRTYRE	PHE F40FRTYRE
40	H	1008	9	25	33,0	22	-	-	-	104	82	-	-	29	-	11,0	0,80	0,00074	PHE F40HTBFLG	PHE F40NRTYRE	PHE F40FRTYRE
50	B	-	11	38	-	-	45,0	32	M5	133	100	79	-	38	-	12,5	1,20	0,00115	PHE F50RSBFLG	PHE F50NRTYRE	PHE F50FRTYRE
50	F	1210	11	32	37,5	25	-	-	-	133	100	79	-	38	-	12,5	1,20	0,00115	PHE F50FTBFLG	PHE F50NRTYRE	PHE F50FRTYRE
50	H	1210	11	32	37,5	25	-	-	-	133	100	79	-	38	-	12,5	1,20	0,00115	PHE F50HTBFLG	PHE F50NRTYRE	PHE F50FRTYRE
60	B	-	14	45	-	-	55,0	38	M6	165	125	70	-	38	-	16,5	2,00	0,0052	PHE F60RSBFLG	PHE F60NRTYRE	PHE F60FRTYRE
60	F	1610	14	42	41,5	25	-	-	-	165	125	103	-	38	-	16,5	2,00	0,0052	PHE F60FTBFLG	PHE F60NRTYRE	PHE F60FRTYRE
60	H	1610	14	42	41,5	25	-	-	-	165	125	103	-	38	-	16,5	2,00	0,0052	PHE F60HTBFLG	PHE F60NRTYRE	PHE F60FRTYRE
70	B	-	14	60	-	-	47,0	35	M10	187	142	80	50	-	13	11,5	3,10	0,009	PHE F70RSBFLG	PHE F70NRTYRE	PHE F70FRTYRE
70	F	2012	14	50	43,5	32	-	-	-	187	142	80	50	42	13	11,5	3,10	0,009	PHE F70FTBFLG	PHE F70NRTYRE	PHE F70FRTYRE
70	H	1610	14	42	36,5	25	-	-	-	187	142	80	50	38	13	11,5	3,00	0,009	PHE F70HTBFLG	PHE F70NRTYRE	PHE F70FRTYRE
80	B	-	16	63	-	-	55,0	42	M10	211	165	98	54	-	16	12,5	4,90	0,018	PHE F80RSBFLG	PHE F80NRTYRE	PHE F80FRTYRE
80	F	2517	16	60	57,5	45	-	-	-	211	165	97	54	48	16	12,5	4,90	0,018	PHE F80FTBFLG	PHE F80NRTYRE	PHE F80FRTYRE
80	H	2012	14	50	44,5	32	-	-	-	211	165	98	54	32	16	12,5	4,60	0,017	PHE F80HTBFLG	PHE F80NRTYRE	PHE F80FRTYRE
90	B	-	16	75	-	-	62,5	49	M12	235	187	112	60	-	16	13,5	7,10	0,032	PHE F90RSBFLG	PHE F90NRTYRE	PHE F90FRTYRE
90	F	2517	16	60	58,5	45	-	-	-	235	187	108	60	48	16	13,5	7,00	0,031	PHE F90FTBFLG	PHE F90NRTYRE	PHE F90FRTYRE
90	H	2517	16	60	58,5	45	-	-	-	235	187	108	60	48	16	13,5	7,00	0,031	PHE F90HTBFLG	PHE F90NRTYRE	PHE F90FRTYRE
100	B	-	25	80	-	-	69,5	56	M12	254	214	125	62	-	16	13,5	9,90	0,055	PHE F100RSBFLG	PHE F100NRTYRE	PHE F100FRTYRE
100	F	3020	25	75	64,5	51	-	-	-	254	214	120	62	55	16	13,5	9,90	0,055	PHE F100FTBFLG	PHE F100NRTYRE	PHE F100FRTYRE
100	H	2517	16	60	58,5	45	-	-	-	254	214	113	62	48	16	13,5	9,40	0,054	PHE F100HTBFLG	PHE F100NRTYRE	PHE F100FRTYRE
110	B	-	25	90	-	-	75,5	63	M12	279	232	128	62	-	16	12,5	12,50	0,081	PHE F110RSBFLG	PHE F110NRTYRE	PHE F110FRTYRE
110	F	3020	25	75	63,5	51	-	-	-	279	232	134	62	55	16	12,5	11,70	0,078	PHE F110FTBFLG	PHE F110NRTYRE	PHE F110FRTYRE
110	H	3020	25	75	63,5	51	-	-	-	279	232	134	62	55	16	12,5	11,70	0,078	PHE F110HTBFLG	PHE F110NRTYRE	PHE F110FRTYRE
120	B	-	35	100	-	-	84,5	70	M16	314	262	143	67	-	16	14,5	16,90	0,137	PHE F120RSBFLG	PHE F120NRTYRE	PHE F120FRTYRE
120	F	3525	35	100	79,5	65	-	-	-	314	262	140	67	67	16	14,5	16,50	0,137	PHE F120FTBFLG	PHE F120NRTYRE	PHE F120FRTYRE
120	H	3020	25	75	65,5	51	-	-	-	314	262	140	67	55	16	14,5	15,90	0,130	PHE F120HTBFLG	PHE F120NRTYRE	PHE F120FRTYRE
140	B	-	35	125	-	-	110,5	94	M20	359	312,5	180	73	-	17	16,0	22,20	0,254	PHE F140RSBFLG	PHE F140NRTYRE	PHE F140FRTYRE
140	F	3525	35	100	81,0	65	-	-	-	359	312,5	180	73	67	17	16,0	22,30	0,255	PHE F140FTBFLG	PHE F140NRTYRE	PHE F140FRTYRE
140	H	3525	35	100	81,0	65	-	-	-	359	312,5	180	73	67	17	16,0	22,30	0,255	PHE F140HTBFLG	PHE F140NRTYRE	PHE F140FRTYRE
160	B	-	40	140	-	-	117,0	102	M20	402	348	197	78	-	19	15,0	35,80	0,469	PHE F160RSBFLG	PHE F160NRTYRE	PHE F160FRTYRE
160	F	4030	40	115	91,0	76	-	-	-	402	348	197	78	80	19	15,0	32,50	0,380	PHE F160FTBFLG	PHE F160NRTYRE	PHE F160FRTYRE
160	H	4030	40	115	91,0	76	-	-	-	402	348	197	78	80	19	15,0	32,50	0,380	PHE F160HTBFLG	PHE F160NRTYRE	PHE F160FRTYRE
180	B	-	55	150	-	-	137,0	114	M20	470	396	205	94	-	19	23,0	49,10	0,871	PHE F180RSBFLG	PHE F180NRTYRE	PHE F180FRTYRE
180	F	4535	55	125	112,0	89	-	-	-	470	396	205	94	89	19	23,0	42,20	0,847	PHE F180FTBFLG	PHE F180NRTYRE	PHE F180FRTYRE
180	H	4535	55	125	112,0	89	-	-	-	470	396	205	94	89	19	23,0	42,20	0,847	PHE F180HTBFLG	PHE F180NRTYRE	PHE F180FRTYRE
200	B	-	55	150	-	-	138,0	114	M20	508	432	205	103	-	19	24,0	58,20	1,301	PHE F200RSBFLG	PHE F200NRTYRE	PHE F200FRTYRE
200	F	4535	55	125	113,0	89	-	-	-	508	432	205	103	89	19	24,0	53,60	1,281	PHE F200FTBFLG	PHE F200NRTYRE	PHE F200FRTYRE
200	H	4535	55	125	113,0	89	-	-	-	508	432	205	103	89	19	24,0	53,60	1,281	PHE F200HTBFLG	PHE F200NRTYRE	PHE F200FRTYRE
220	B	-	70	160	-	-	154,5	127	M20	562	472	224	118	-	20	27,5	79,60	2,142	PHE F220RSBFLG	PHE F220NRTYRE	PHE F220FRTYRE
220	F	5040	70	125	129,5	102	-	-	-	562	472	224	118	92	20	27,5	72,00	2,104	PHE F220FTBFLG	PHE F220NRTYRE	PHE F220FRTYRE
220	H	5040	70	125	129,5	102	-	-	-	562	472	224	118	92	20	27,5	72,00	2,104	PHE F220HTBFLG	PHE F220NRTYRE	PHE F220FRTYRE
250	B	-	-	190	-	-	161,5	132	M20	628	532	254	125	-	25	29,5	104,00	3,505	PHE F250RSBFLG	PHE F250NRTYRE	PHE F250FRTYRE

¹⁾ Is the clearance required to allow tightening of the clamping screws and the tapered bushing. Use of a shortened wrench will reduce this dimension.

²⁾ The amount by which the clamping screws need to be withdrawn to release the tyre.

For coupling sizes 70, 80, 100 and 120 "F" flanges require a larger bushing than "H" flanges.

Mass and inertia figures are for a single flange with midrange bore and include clamping ring, screws, washers and half tyre.

SKF Flex Spacer Coupling

The SKF Flex coupling spacer is used to join two shaft ends that cannot be positioned close enough to just use a coupling alone.

The spacer also allows removal of a shaft without the need to move either the driving or the driven machine. For example, this allows easy and fast replacement of impellers in pump applications.

Installation

- 1 Place each tapered bushing in the correct flange and tighten the screws lightly.
- 2 If keys are being used, side fitting keys with top clearance should be used.
- 3 Use a straight edge to align the face of the clamping ring for coupling sizes F40–F60 (→ **fig. 1a**) or the flange for coupling sizes F70–F250 (→ **fig. 1b**) with the shaft end. A dial indicator can be used to check that the runout of the spacer flange is within limits indicated in **fig. 1a** and **b**.

Position the SKF Flex flange on the spacer flange shaft to dimension “Y” shown in **table 7** and secure it with a tapered bushing. This will allow for “M” and DBSE dimensions (→ **fig. 1c**) to be maintained when assembling. If necessary, the distance between shaft ends (DBSE) may be extended. The maximum DBSE possible is achieved when the spacer shaft end and driven shaft end are flush with the face of their respective tapered bushings.

- 4 Position the spacer sub-assembly in line with the spacer flange (→ **fig. 1d**), engage spigot align holes and insert screws. The torque values are given in **table 8**. Spread the tyre side walls apart and fit over the coupling flanges making sure that the tyre beads seat properly on the flanges and clamping rings.

To make sure that the tyre sits properly in position, it may be necessary to strike the outside diameter of the tyre with a small mallet. When the tyre is correctly positioned, there should be a gap between the ends of the tyre as shown in **table 5**.

- 5 Tighten the clamping ring screws alternately and evenly (half turn at a time), working around each flange until the required screw torque is achieved, as indicated in **table 8**.

To dismantle

- 1 Place a support underneath the spacer sub-assembly to prevent it from falling.
- 2 Remove clamping ring screws evenly (half turn per screw at a time) to prevent the clamping rings from distorting.
- 3 When the clamping rings are loose, remove the tyre. Then remove the remaining screws and spacer.

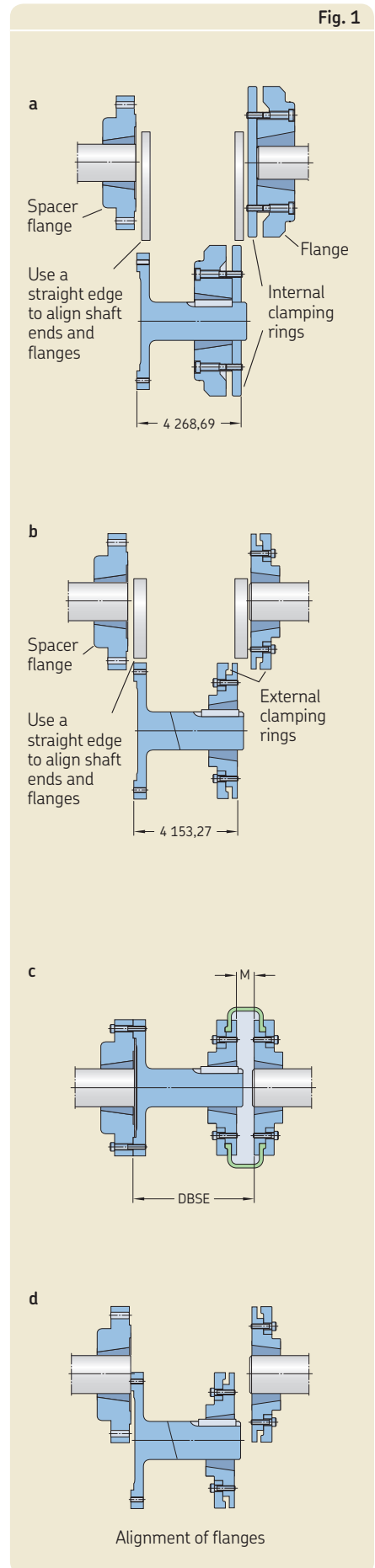

Table 6

Additional dimensions

Coupling size	Distance between shaft ends (DBSE)		Spacer bushing size	Bore		Coupling bushing size	Bore		Designation
	Nominal	Nominal		Min.	Max.		Min.	Max.	
mm	–	–	–	–	–	–	–	–	–
40	80	90	1 210	11	32	1 008	9	25	PHE SM12–80DBSE
40	100	110	1 210	11	32	1 008	9	25	PHE SM12–100DBSE
40	100	113	1 615	14	42	1 008	9	25	PHE SM16–100DBSE
40	140	150	1 615	14	42	1 008	9	25	PHE SM16–140DBSE
50	100	116	1 615	14	42	1 210	11	32	PHE SM16–100DBSE
50	140	156	1 615	14	42	1 210	11	32	PHE SM16–140DBSE
60	100	124	1 615	14	42	1 610	14	42	PHE SM16–100DBSE
60	140	164	1 615	14	42	1 610	14	42	PHE SM16–140DBSE
70	100	114	2 517	16	60	2 012	14	50	PHE SM25–100DBSE
70	140	154	2 517	16	60	2 012	14	50	PHE SM25–140DBSE
70	180	194	2 517	16	60	2 012	14	50	PHE SM25–180DBSE
80	100	117	2 517	16	60	2 517	16	60	PHE SM25–100DBSE
80	140	157	2 517	16	60	2 517	16	60	PHE SM25–140DBSE
80	180	197	2 517	16	60	2 517	16	60	PHE SM25–180DBSE
90	140	158	2 517	16	60	2 517	16	60	PHE SM25–140DBSE
90	180	198	2 517	16	60	2 517	16	60	PHE SM25–180DBSE
100	140	158	3 020	25	75	3 020	25	75	PHE SM30–140DBSE
100	180	198	3 020	25	75	3 020	25	75	PHE SM30–180DBSE
110	140	156	3 020	25	75	3 020	25	75	PHE SM30–140DBSE
110	180	196	3 020	25	75	3 020	25	75	PHE SM30–180DBSE
120	140	160	3 525	35	100	3 525	35	100	PHE SM35–140DBSE
120	180	200	3 525	35	100	3 525	35	100	PHE SM35–180DBSE
140	140	163	3 525	35	100	3 525	35	100	PHE SM35–140DBSE
140	180	203	3 525	35	100	3 525	35	100	PHE SM35–180DBSE

Table 7

Additional assembly data

Size	"Y" for nominal DBSE		
	100	140	180
–	mm		
40	83	123	–
50	82	122	–
60	75	115	155
70	76	116	156
80	74	114	154
90	111	151	–
100	111	151	–
110	115	155	–
120	111	151	–
140	104	144	–

Table 8

Clamping screw torque

Size	Screw size	Torque
–	–	Nm
40	83	123
50	82	122
60	75	115
70	76	116
80	74	114
90	111	151
100	111	151
110	115	155
120	111	151
140	104	144

SKF Flex Spacer Coupling

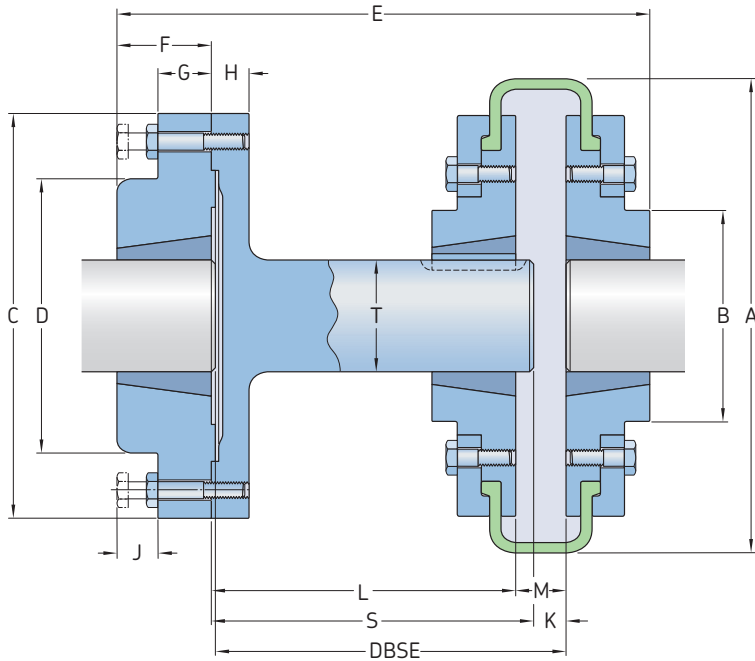

Coupling size	Dimensions														Designation
	A	B	C	D	E	F	G	H	J	K	L	M	S	T	
mm	mm														-
40	104	82	118	83	134	25	14	15	14	6	65	22	77	25	PHE SM12-80DBSE
40	104	82	118	83	140	25	14	15	14	22	77	22	77	25	PHE SM12-100DBSE
40 ¹⁾	104	82	127	80	157	38	18	15	14	9	88	22	94	32	PHE SM16-100DBSE
40 ¹⁾	104	82	127	80	187	38	18	15	14	9	128	22	134	32	PHE SM16-140DBSE
50	133	79	127	80	160	38	18	15	14	9	85	25	94	32	PHE SM16-100DBSE
50	133	79	127	80	200	38	18	15	14	9	125	25	134	32	PHE SM16-140DBSE
60	165	103	127	80	161	38	18	15	14	9	78	33	94	32	PHE SM16-100DBSE
60	165	103	127	80	201	38	18	15	14	9	118	33	134	32	PHE SM16-140DBSE
70 ²⁾	187	80	178	123	180	45	22	16	14	9	80	23	94	48	PHE SM25-100DBSE
70 ²⁾	187	80	178	123	220	45	22	16	14	9	120	23	174	48	PHE SM25-140DBSE
70 ²⁾	187	80	178	123	260	45	22	16	14	9	160	23	174	48	PHE SM25-180DBSE
80	211	95	178	123	193	45	22	16	14	9	78	25	94	48	PHE SM25-100DBSE
80	211	95	178	123	233	45	22	16	14	9	118	25	134	48	PHE SM25-140DBSE
80	211	95	178	123	273	45	22	16	14	9	158	25	174	48	PHE SM25-180DBSE
90	235	108	178	123	233	45	22	16	14	9	116	27	134	48	PHE SM25-140DBSE
90	235	108	178	123	273	45	22	16	14	9	156	27	174	48	PHE SM25-180DBSE
100	254	120	216	146	245	51	29	20	17	9	116	27	134	60	PHE SM30-140DBSE
100	254	120	216	146	285	51	29	20	17	9	156	27	174	60	PHE SM30-180DBSE
110	279	134	216	146	245	51	29	20	17	9	118	25	134	60	PHE SM30-140DBSE
110	279	134	216	146	285	51	29	20	17	9	158	25	174	60	PHE SM30-180DBSE
120	314	140	248	178	272	63	34	20	17	9	114	29	134	80	PHE SM35-140DBSE
120	314	140	248	178	312	63	34	20	17	9	154	29	174	80	PHE SM35-180DBSE
140	359	178	248	178	271	63	34	20	17	9	111	27	134	80	PHE SM35-140DBSE
140	359	178	248	178	312	63	34	20	17	9	151	27	174	80	PHE SM35-180DBSE

¹⁾ "B" Flange must be used to fit spacer shaft

²⁾ "F" Flange must be used to fit spacer shaft