

Pulegge dentate HTD® per bussola conica
HTD® Timing belt pulleys for taper bushes
HTD® Zahnriemenscheiben für Spannbüchsen
Poulies dentées HTD® pour moyeux amovibles
Poleas dentadas HTD® para casquillos cónicos

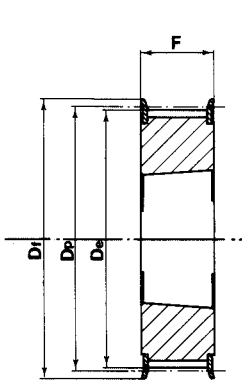

Pulegge dentate HTD® per bussola conica
 HTD® Timing belt pulleys for taper bushes
 HTD® Zahnriemenscheiben für Spannbüchsen
 Poulies dentées HTD® pour moyeux amovibles
 Poleas dentadas HTD® para casquillos cónicos



tipo
type 3F

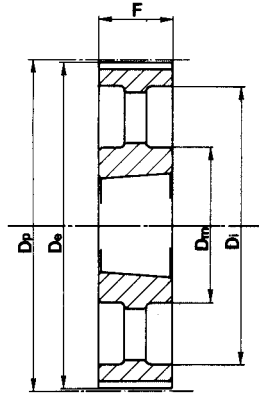

tipo
type 3A

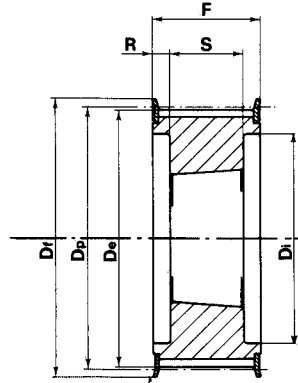

tipo
type 4F

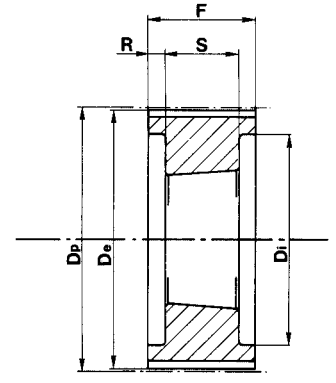

tipo
type 4

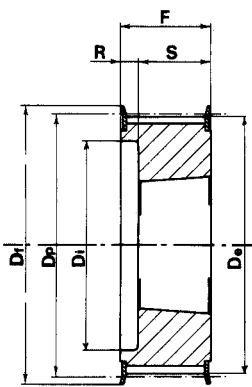

tipo
type 5F

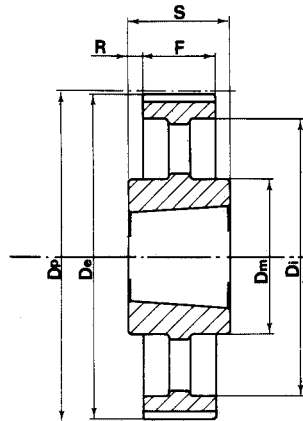

tipo
type 7A

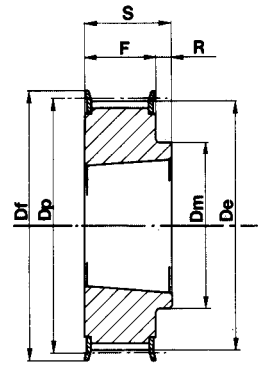

tipo
type 8F

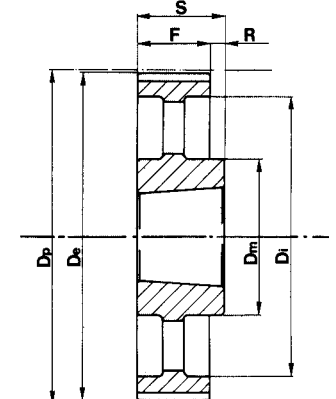

tipo
type 8W

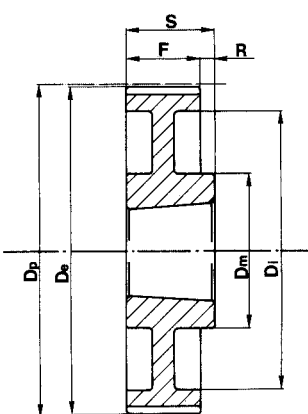

tipo
type 8A

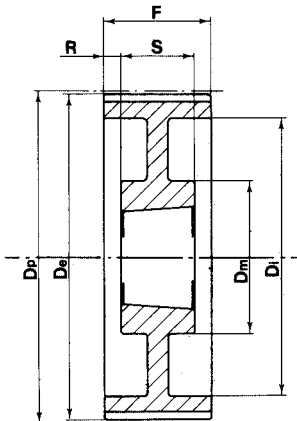

tipo
type 9W

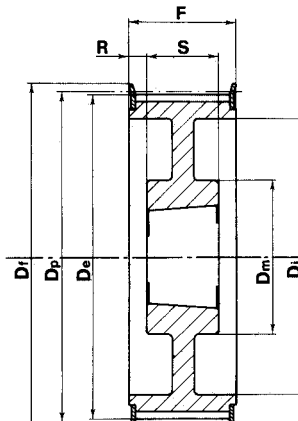

tipo
type 9WF

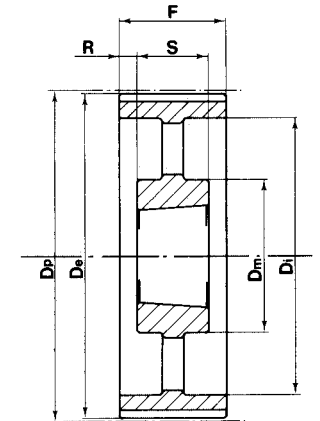

tipo
type 9A

Pulegge dentate HTD® per bussola conica
HTD® Timing belt pulleys for taper bushes
HTD® Zahnriemenscheiben für Spannbüchsen
Poulies dentées HTD® pour moyeux amovibles
Poleas dentadas HTD® para casquillos cónicos



HTD® 5M-15

CARATTERISTICHE FEATURES MERKMALE CARACTERISTIQUES CARACTERÍSTICAS		CODICE CODE SYMBOL FABRIKNUMMER CODE SYMBOLE NUMERO DE FABRICA	NOSTRO CODICE OUR CODE UNSER KODE NOTRE CODE NUESTRO CODIGO	TIPO TYPE TYP TYPE TIPO	TIPO FLANGIA FLANGES TYPE BORDSCHEIBEN TYP TYPE FLASQUES TIPO TAPETAS	BUSSOLA BUSH BUCHSE MOYEU CASQUILLO	FORO MAX. MAX. BORE MAX. BOHRUNG ALESAGE MAX. AGUJERO MAX.	Dp	De	Df	Dm	Di	F	S	R	PESO WEIGHT GEWICHT POIDS PESO Kg
ACCIAIO STEEL STAHL ACIER ACERO	CON FLANGIA WITH FLANGES MIT FLANGES AVEC FLASQUES CON TAPETAS	34-5M-15	0515034	3F	F21	1008	25	54,11	52,97	57	-	-	22	22	-	
		36-5M-15	0515036	3F	F22	1108	25	57,30	56,15	60	-	-	22	22	-	
		38-5M-15	0515038	3F	F25	1108	25	60,48	59,34	66	-	-	22	22	-	
		40-5M-15	0515040	3F	F26	1108	25	63,66	62,52	70	-	-	22	22	-	
		44-5M-15	0515044	3F	F27	1108	25	70,03	68,89	75	-	-	22	22	-	
		48-5M-15	0515048	8F	F29	1210	32	76,39	75,25	83	59	-	22	25	3	
		56-5M-15	0515056	8F	F32	1210	32	89,13	87,39	93	70	-	22	25	3	
		64-5M-15	0515064	8F	F35	1210	32	101,86	100,72	106	80	-	22	25	3	
	SENZA FLANGIA WITHOUT FLANGES OHNE FLANSCHEN SANS FLASQUES SIN TAPETAS	72-5M-15	0515072	8	-	1610	42	114,59	113,45	-	92	-	22	25	3	
		80-5M-15	0515080	8	-	1610	42	127,32	126,18	-	92	-	22	25	3	
		90-5M-15	0515090	8	-	1610	42	143,24	142,10	-	92	-	22	25	3	
		112-5M-15	0515112	8	-	2012	50	178,25	177,11	-	110	-	20	32	12	
		136-5M-15	0515136	7A	-	2012	50	216,45	215,31	-	110	199	20	32	6	

Pulegge dentate HTD® per bussola conica
HTD® Timing belt pulleys for taper bushes
HTD® Zahnriemenscheiben für Spannbüchsen
Poulies dentées HTD® pour moyeux amovibles
Poleas dentadas HTD® para casquillos cónicos

HTD® 8M-20

CARATTERISTICHE FEATURES MERKMALE CARACTERISTIQUES CARACTERÍSTICAS		CODICE CODE SYMBOL FABRIKNUMMER CODE SYMBOLE NUMERO DE FABRICA	NOSTRO CODICE OUR CODE UNSER KODE NOTRE CODE NUESTRO CODIGO	TIPO TYPE TYP TYPE TIPO	TIPO FLANGIA FLANGES TYPE BORDSCHEIBEN TYP TYPE FLASQUES TIPO TAPETAS	BUSSOLA BUSH BUCHSE MOYEU CASQUILLO	FORO MAX. MAX. BORE MAX. BOHRUNG ALESAGE MAX. AGUJERO MAX.	Dp	De	Df	Dm	Di	F	S	R	PESO WEIGHT GEWICHT POIDS PESO Kg
ACCIAIO STEEL STAHL ACIER ACERO	CON FLANGIA WITH FLANGES MIT FLANGES AVEC FLASQUES CON TAPETAS	22-8M-20	0820022	5F	F22	1108	25	56,02	54,65	60	—	37	28	22	6	0,25
		24-8M-20	0820024	5F	F25	1108	25	61,12	59,75	66	—	44	28	22	6	0,30
		26-8M-20	0820026	5F	F26	1108	25	66,21	64,84	70	—	45	28	22	6	0,36
		28-8M-20	0820028	5F	F27	1108	25	71,30	70,08	75	—	50	28	22	6	0,44
		30-8M-20	0820030	5F	F29	1108	25	76,39	75,13	83	—	58	28	22	6	0,53
		32-8M-20	0820032	5F	F30	1610	42	81,49	80,16	87	—	63	28	25	3	0,42
		34-8M-20	0820034	5F	F31	1610	42	86,58	85,22	91	—	64	28	25	3	0,55
		36-8M-20	0820036	5F	F33	1610	42	91,67	90,30	97	—	68	28	25	3	0,68
		38-8M-20	0820038	5F	F34	1610	42	96,77	95,39	102	—	72	28	25	3	0,80
		40-8M-20	0820040	5F	F35	1610	42	101,86	100,49	106	—	76	28	25	3	1,00
		44-8M-20	0820044	8F	F38	2012	50	112,05	110,67	120	93	—	28	32	4	1,20
		48-8M-20	0820048	8F	F40	2012	50	122,23	120,86	128	96	—	28	32	4	1,60
		56-8M-20	0820056	8F	F48	2012	50	142,60	141,23	150	110	—	28	32	4	2,40
		64-8M-20	0820064	8WF	F52	2012	50	162,97	161,60	168	110	137	28	32	4	2,70
72-8M-20	0820072	8WF	F57	2012	50	183,35	181,97	192	110	158	28	32	4	3,30		
GHISA CAST IRON GRAUGUSS FONTE HIERRO FUNDIDO	SENZA FLANGIA WITHOUT FLANGES OHNE FLANSCHEN SANS FLASQUES SIN TAPETAS	80-8M-20	0820080	8W		2012	50	203,72	202,35	—	110	180	28	32	4	3,50
		90-8M-20	0820090	8A		2012	50	229,18	227,81	—	110	204	28	32	4	3,65
		112-8M-20	0820112	8A		2517	60	285,21	283,83	—	125	254	38	45	7	6,20
		144-8M-20	0820144	8A		2517	60	366,69	365,32	—	125	336	28	32	4	4,80

HTD® 8M-30

CARATTERISTICHE FEATURES MERKMALE CARACTERISTIQUES CARACTERÍSTICAS		CODICE CODE SYMBOL FABRIKNUMMER CODE SYMBOLE NUMERO DE FABRICA	NOSTRO CODICE OUR CODE UNSER KODE NOTRE CODE NUESTRO CODIGO	TIPO TYPE TYP TYPE TIPO	TIPO FLANGIA FLANGES TYPE BORDSCHEIBEN TYP TYPE FLASQUES TIPO TAPETAS	BUSSOLA BUSH BUCHSE MOYEU CASQUILLO	FORO MAX. MAX. BORE MAX. BOHRUNG ALESAGE MAX. AGUJERO MAX.	Dp	De	Df	Dm	Di	F	S	R	PESO WEIGHT GEWICHT POIDS PESO Kg
ACCIAIO STEEL STAHL ACIER ACERO	CON FLANGIA WITH FLANGES MIT FLANGES AVEC FLASQUES CON TAPETAS	22-8M-30	0830022	5F	F22	1108	25	56,02	54,65	60	—	37	38	22	16	0,31
		24-8M-30	0830024	5F	F25	1108	25	61,12	59,75	66	—	44	38	22	16	0,38
		26-8M-30	0830026	5F	F26	1108	25	66,21	64,84	70	—	44	38	22	16	0,45
		28-8M-30	0830028	5F	F27	1210	32	71,30	70,08	75	—	50	38	25	13	0,50
		30-8M-30	0830030	3F	F29	1615	42	76,39	75,13	83	—	—	38	38	—	0,55
		32-8M-30	0830032	3F	F30	1615	42	81,49	80,16	87	—	—	38	38	—	0,59
		34-8M-30	0830034	3F	F31	1615	42	86,58	85,22	91	—	—	38	38	—	0,77
		36-8M-30	0830036	3F	F33	1615	42	91,67	90,30	97	—	—	38	38	—	0,96
		38-8M-30	0830038	3F	F34	1615	42	96,77	95,39	102	—	—	38	38	—	1,15
		40-8M-30	0830040	3F	F35	1615	42	101,86	100,49	106	—	—	38	38	—	1,34
		44-8M-30	0830044	4F	F38	2012	50	112,05	110,67	120	—	86	38	32	6	1,33
		48-8M-30	0830048	4F	F40	2012	50	122,23	120,86	128	—	90	38	32	6	1,78
		56-8M-30	0830056	4F	F48	2012	50	142,60	141,23	150	—	110	38	32	6	3,76
		64-8M-30	0830064	8F	F52	2517	60	162,97	161,60	168	—	125	—	38	45	7
72-8M-30	0830072	8WF	F57	2517	60	183,35	181,97	192	—	125	158	38	45	7	4,30	
GHISA CAST IRON GRAUGUSS FONTE HIERRO FUNDIDO	SENZA FLANGIA WITHOUT FLANGES OHNE FLANSCHEN SANS FLASQUES SIN TAPETAS	80-8M-30	0830080	8W		2517	60	203,72	202,35	—	125	180	38	45	7	4,60
		90-8M-30	0830090	8A		2517	60	229,18	227,81	—	125	204	38	45	7	5,00
		112-8M-30	0830112	8A		2517	60	285,21	283,83	—	125	254	38	45	7	6,20
		144-8M-30	0830144	8A		2517	60	366,69	365,32	—	125	336	38	45	7	9,00

Pulegge dentate HTD® per bussola conica
HTD® Timing belt pulleys for taper bushes
HTD® Zahnriemenscheiben für Spannbüchsen
Poulies dentées HTD® pour moyeux amovibles
Poleas dentadas HTD® para casquillos cónicos



HTD® 8M-50

CARATTERISTICHE FEATURES MERKMALE CARACTERISTIQUES CARACTERÍSTICAS		CODICE CODE SYMBOL FABRIKNUMMER CODE SYMBOLE NUMERO DE FABRICA	NOSTRO CODICE OUR CODE UNSER KODE NOTRE CODE NUESTRO CODIGO	TIPO TYPE TYP TYPE TIPO	TIPO FLANGIA FLANGES TYPE BORDSCHEIBEN TYP TYPE FLASQUES TIPO TAPETAS	BUSSOLA BUSH BUCHSE MOYEU CASQUILLO	FORO MAX. MAX. BORE MAX. BOHRUNG ALESAGE MAX. AGUJERO MAX.	Dp	De	Df	Dm	Di	F	S	R	PESO WEIGHT GEWICHT POIDS PESO Kg
ACCIAIO STEEL STAHL ACIER ACERO	CON FLANGIA WITH FLANGES MIT FLANGES AVEC FLASQUES CON TAPETAS	28-8M-50	0850028	4F	F27	1210	32	71,30	70,08	75	—	50	60	25	17,5	0,60
		30-8M-50	0850030	5F	F29	1615	42	76,39	75,13	83	—	58	60	38	22	0,65
		32-8M-50	0850032	5F	F30	1615	42	81,49	80,16	87	—	62	60	38	22	0,82
		34-8M-50	0850034	5F	F31	1615	42	86,58	85,22	91	—	65	60	38	22	1,06
		36-8M-50	0850036	5F	F33	1615	42	91,67	90,30	97	—	68	60	38	22	1,30
		38-8M-50	0850038	5F	F34	1615	42	96,77	95,39	102	—	72	60	38	22	1,60
		40-8M-50	0850040	4F	F35	2012	50	101,86	100,49	106	—	82	60	32	14	1,71
		44-8M-50	0850044	4F	F38	2012	50	112,05	110,67	120	—	91	60	32	14	1,78
		48-8M-50	0850048	4F	F40	2012	50	122,23	120,86	128	—	95	60	32	14	2,30
		56-8M-50	0850056	4F	F48	2517	60	142,60	141,23	150	—	116	60	45	7,5	3,40
		64-8M-50	0850064	4F	F52	2517	60	162,97	161,60	168	—	137	60	45	7,5	5,00
72-8M-50	0850072	9WF	F57	2517	60	183,35	181,97	192	125	158	60	45	7,5	6,70		
GHISA CAST IRON GRAUGUSS FONTE HIERRO FUNDIDO	SENZA FLANGIA WITHOUT FLANGES OHNE FLANSCHEN SANS FLASQUES SIN TAPETAS	80-8M-50	0850080	4		3020	75	203,72	202,35	—	—	180	60	51	4,5	8,80
		90-8M-50	0850090	9W		3020	75	229,18	227,81	—	170	204	60	51	4,5	10,00
		112-8M-50	0850112	9W		3020	75	285,21	283,83	—	170	260	60	51	4,5	12,00
		144-8M-50	0850144	9A		3020	75	366,69	365,32	—	170	341	60	51	2,5	15,20
		168-8M-50	0850168	9A		3020	75	427,81	426,44	—	170	402	60	51	2,5	17,50
		192-8M-50	0850192	9A		3020	75	488,92	487,55	—	170	460	60	51	2,5	24,00

HTD® 8M-85

CARATTERISTICHE FEATURES MERKMALE CARACTERISTIQUES CARACTERÍSTICAS		CODICE CODE SYMBOL FABRIKNUMMER CODE SYMBOLE NUMERO DE FABRICA	NOSTRO CODICE OUR CODE UNSER KODE NOTRE CODE NUESTRO CODIGO	TIPO TYPE TYP TYPE TIPO	TIPO FLANGIA FLANGES TYPE BORDSCHEIBEN TYP TYPE FLASQUES TIPO TAPETAS	BUSSOLA BUSH BUCHSE MOYEU CASQUILLO	FORO MAX. MAX. BORE MAX. BOHRUNG ALESAGE MAX. AGUJERO MAX.	Dp	De	Df	Dm	Di	F	S	R	PESO WEIGHT GEWICHT POIDS PESO Kg
ACCIAIO STEEL STAHL ACIER ACERO	CON FLANGIA WITH FLANGES MIT FLANGES AVEC FLASQUES CON TAPETAS	34-8M-85	0885034	4F	F31	1615	42	86,58	85,22	91	—	65	95	38	28,5	1,43
		36-8M-85	0885036	4F	F33	1615	42	91,67	90,30	97	—	68	95	38	28,5	1,87
		38-8M-85	0885038	4F	F34	1615	42	96,77	95,39	102	—	72	95	38	28,5	2,20
		40-8M-85	0885040	4F	F35	2012	50	101,86	100,49	106	—	82	95	32	31,5	1,80
		44-8M-85	0885044	4F	F38	2012	50	112,05	110,67	120	—	91	95	32	31,5	2,30
		48-8M-85	0885048	4F	F40	2517	60	122,23	120,86	128	—	100	95	45	25	2,66
		56-8M-85	0885056	4F	F48	2517	60	142,60	141,23	150	—	117	95	45	25	4,45
		64-8M-85	0885064	4F	F52	2517	60	162,97	161,60	168	—	137	95	45	25	6,20
72-8M-85	0885072	4F	F57	3020	75	183,35	181,97	192	—	158	95	51	22	8,00		
GHISA CAST IRON GRAUGUSS FONTE HIERRO FUNDIDO	SENZA FLANGIA WITHOUT FLANGES OHNE FLANSCHEN SANS FLASQUES SIN TAPETAS	80-8M-85	0885080	4		3020	75	203,72	202,35	—	—	180	95	51	22	10,00
		90-8M-85	0885090	9W		3020	75	229,18	227,81	—	170	204	95	51	22	10,80
		112-8M-85	0885112	9W		3020	75	285,21	283,83	—	170	260	95	51	22	15,00
		144-8M-85	0885144	9A		3525	90	366,69	365,32	—	198	336	95	65	15	20,00
		168-8M-85	0885168	9A		3525	90	427,81	426,44	—	198	395	95	65	15	22,00
		192-8M-85	0885192	9A		3525	90	488,92	487,55	—	198	455	95	65	15	26,00

Pulegge dentate HTD® per bussola conica
 HTD® Timing belt pulleys for taper bushes
 HTD® Zahnriemenscheiben für Spannbüchsen
 Poulies dentées HTD® pour moyeux amovibles
 Poleas dentadas HTD® para casquillos cónicos

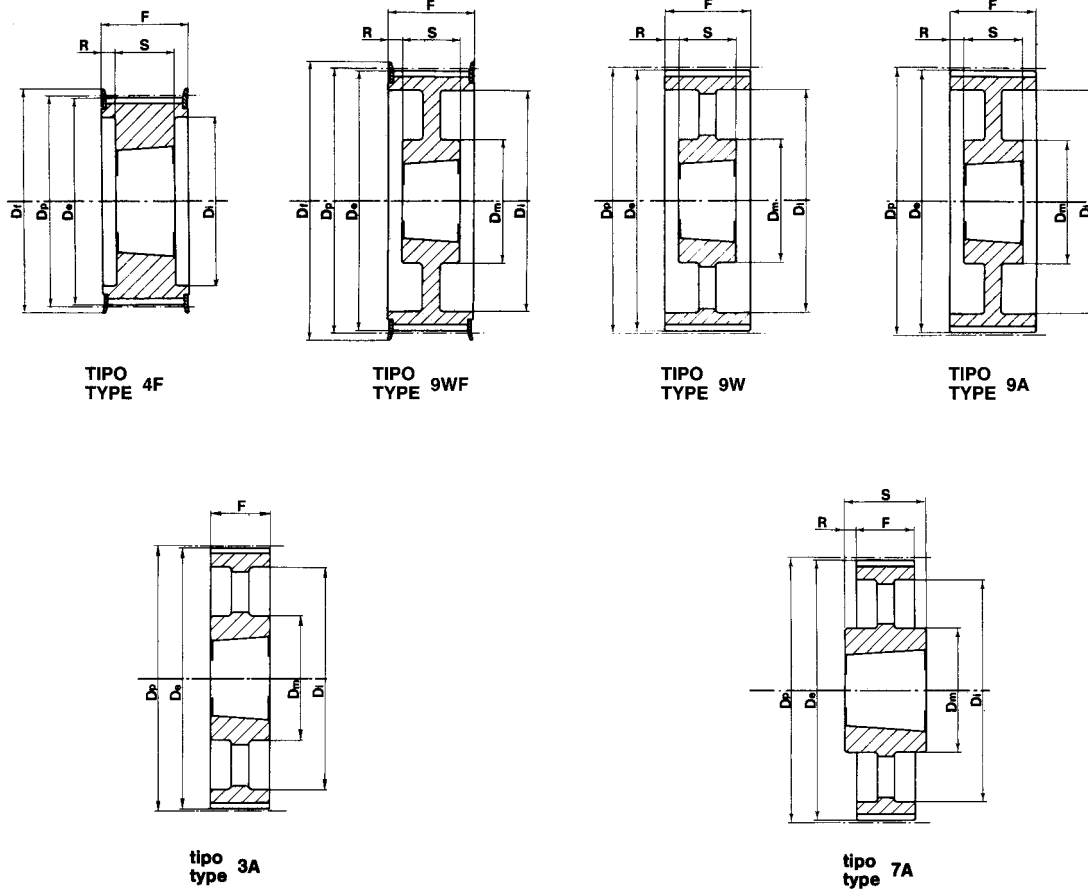

HTD® 14M-40

CARATTERISTICHE FEATURES MERKMALE CARACTERISTIQUES CARACTERÍSTICAS		CODICE CODE SYMBOL FABRIKNUMMER CODE SYMBOLE NUMERO DE FABRICA	NOSTRO CODICE OUR CODE UNSER KODE NOTRE CODE NUESTRO CODIGO	TIPO TYPE TYP TYPE TIPO	TIPO FLANGIA FLANGES TYPE BORDSCHEIBEN TYP TYPE FLASQUES TIPO TAPETAS	BUSSOLA BUSH BUCHSE MOYEU CASQUILLO	FORO MAX. MAX. BORE MAX. BOHRUNG ALESAGE MAX. AGUJERO MAX.	Dp	De	Df	Dm	Di	F	S	R	PESO WEIGHT GEWICHT POIDS PESO Kg
ACCIAIO STEEL STAHL ACIER ACERO	CON FLANGIA WITH FLANGES MIT FLANGES AVEC FLASQUES CON TAPETAS	28 14M-40	1440028	4F	F40	2012	50	124,78	122,12	128	—	94	54	32	11	2,07
		29 14M-40	1440029	4F	F43	2012	50	129,23	126,57	138	—	98	54	32	11	2,38
		30 14M-40	1440030	4F	F43	2012	50	133,69	130,99	138	—	98	54	32	11	2,65
		32 14M-40	1440032	4F	F49	2012	50	142,60	139,88	154	—	108	54	32	11	3,40
		34 14M-40	1440034	4F	F51	2517	60	151,52	148,79	160	—	110	54	45	4,5	3,87
		36 14M-40	1440036	4F	F52	2517	60	160,43	157,68	168	—	120	54	45	4,5	4,80
		38 14M-40	1440038	4F	F55	2517	60	169,34	166,60	184	—	130	54	45	4,5	5,40
		40 14M-40	1440040	4F	F56	2517	60	178,25	175,49	188	—	138	54	45	4,5	6,00
		44 14M-40	1440044	4F	F61	3020	75	196,08	193,28	212	—	155	54	51	1,5	7,80
		48 14M-40	1440048	4F	F62	3020	75	213,90	211,11	226	—	170	54	51	1,5	9,40
GHISA CAST IRON GRAUGUSS FONTE HIERRO FUNDIDO	SENZA FLANGIA WITHOUT FLANGES OHNE FLANSCHEN SANS FLASQUES SIN TAPETAS	56 14M-40	1440056	9WF	F66	3020	75	249,55	246,76	256	170	208	54	51	1,5	10,80
		64 14M-40	1440064	9WF	F70	3020	75	285,21	282,41	296	170	240	54	51	1,5	13,40
		72 14M-40	1440072	9W		3020	75	320,86	318,06	—	170	280	54	51	1,5	15,20
		80 14M-40	1440080	9A		3020	75	356,51	353,71	—	170	315	54	51	1,5	16,00
		90 14M-40	1440090	9A		3020	75	401,07	398,28	—	170	360	54	51	1,5	17,80
		112 14M-40	1440112	9A		3020	75	499,11	496,32	—	170	457	54	51	1,5	25,60
		144 14M-40	1440144	9A		3020	75	641,71	638,92	—	170	600	54	51	1,5	32,00
		168 14M-40	1440168	9A		3020	75	748,66	745,87	—	170	706	54	51	1,5	44,00
		192 14M-40	1440192	9A		3020	75	855,62	852,82	—	170	813	54	51	1,5	49,00
		216 14M-40	1440216	9A		3020	75	962,57	959,76	—	170	920	54	51	1,5	55,00

Pulegge dentate HTD® per bussola conica
HTD® Timing belt pulleys for taper bushes
HTD® Zahnriemenscheiben für Spannbüchsen
Poulies dentées HTD® pour moyeux amovibles
Poleas dentadas HTD® para casquillos cónicos



HTD® 14M-55

CARATTERISTICHE FEATURES MERKMALE CARACTERISTIQUES CARACTERÍSTICAS		CODICE CODE SYMBOL FABRIKNUMMER CODE SYMBOLE NUMERO DE FABRICA	NOSTRO CODICE OUR CODE UNSER KODE NOTRE CODE NUESTRO CODIGO	TIPO TYPE TYP TYPE TIPO	TIPO FLANGIA FLANGES TYPE BORDSCHEIBEN TYP TYPE FLASQUES TIPO TAPETAS	BUSSOLA BUSH BUCHSE MOYEU CASQUILLO	FORO MAX. MAX. BORE MAX. BOHRUNG ALESAGE MAX. AGUJERO MAX.	Dp	De	Df	Dm	Di	F	S	R	PESO WEIGHT GEWICHT POIDS PESO Kg
ACCIAIO STEEL STAHL ACIER ACERO	CON FLANGIA WITH FLANGES MIT FLANGES AVEC FLASQUES CON TAPETAS	28-14M-55	1455028	4F	F40	2012	50	124,78	122,12	128	—	94	70	32	19	2,20
		29-14M-55	1455029	4F	F43	2012	50	129,23	126,57	138	—	100	70	32	19	2,74
		30-14M-55	1455030	4F	F43	2517	60	133,69	130,99	138	—	100	70	45	12,5	2,70
		32-14M-55	1455032	4F	F49	2517	60	142,60	139,88	154	—	108	70	45	12,5	3,66
		34-14M-55	1455034	4F	F51	2517	60	151,52	148,79	160	—	110	70	45	12,5	4,55
		36-14M-55	1455036	4F	F52	2517	60	160,43	157,68	168	—	120	70	45	12,5	5,20
		38-14M-55	1455038	4F	F55	2517	60	169,34	166,60	184	—	130	70	45	12,5	6,20
		40-14M-55	1455040	4F	F56	2517	60	178,25	175,49	188	—	138	70	45	12,5	7,00
		44-14M-55	1455044	4F	F61	3020	75	196,08	193,28	212	—	155	70	51	9,5	8,60
		48-14M-55	1455048	4F	F62	3020	75	213,90	211,11	226	—	170	70	51	9,5	10,40
GHISA CAST IRON GRAUGUSS FONTE HIERRO FUNDIDO	SENZA FLANGIA WITHOUT FLANGES OHNE FLANSCHEN SANS FLASQUES SIN TAPETAS	56-14M-55	1455056	9WF	F66	3020	75	249,55	246,76	256	170	208	70	51	9,5	12,40
		64-14M-55	1455064	9WF	F70	3020	75	285,21	282,41	296	170	240	70	51	9,5	14,50
		72-14M-55	1455072	9W		3020	75	320,86	318,06	—	170	280	70	51	9,5	16,20
		80-14M-55	1455080	9A		3020	75	356,51	353,71	—	170	315	70	51	9,5	17,50
		90-14M-55	1455090	9A		3020	75	401,07	398,28	—	170	360	70	51	9,5	20,10
		112-14M-55	1455112	9A		3020	75	499,11	496,32	—	170	457	70	51	9,5	28,40
		144-14M-55	1455144	9A		3020	75	641,71	638,92	—	170	600	70	51	9,5	36,20
		168-14M-55	1455168	9A		3020	75	748,66	745,87	—	170	706	70	51	9,5	49,00
		192-14M-55	1455192	9A		3020	75	855,62	852,82	—	170	813	70	51	9,5	53,00
		216-14M-55	1455216	7A		3535	90	962,57	959,76	—	190	920	70	89	9,5	65,80

HTD® 14M-85

CARATTERISTICHE FEATURES MERKMALE CARACTERISTIQUES CARACTERÍSTICAS		CODICE CODE SYMBOL FABRIKNUMMER CODE SYMBOLE NUMERO DE FABRICA	NOSTRO CODICE OUR CODE UNSER KODE NOTRE CODE NUESTRO CODIGO	TIPO TYPE TYP TYPE TIPO	TIPO FLANGIA FLANGES TYPE BORDSCHEIBEN TYP TYPE FLASQUES TIPO TAPETAS	BUSSOLA BUSH BUCHSE MOYEU CASQUILLO	FORO MAX. MAX. BORE MAX. BOHRUNG ALESAGE MAX. AGUJERO MAX.	Dp	De	Df	Dm	Di	F	S	R	PESO WEIGHT GEWICHT POIDS PESO Kg
ACCIAIO STEEL STAHL ACIER ACERO	CON FLANGIA WITH FLANGES MIT FLANGES AVEC FLASQUES CON TAPETAS	28-14M-85	1485028	4F	F40	2517	60	124,78	122,12	128	—	98	102	45	28,5	2,70
		29-14M-85	1485029	5F	F43	2517	60	129,23	126,57	138	—	100	102	45	28,5	3,40
		30-14M-85	1485030	5F	F43	2517	60	133,69	130,99	138	—	100	102	45	28,5	3,75
		32-14M-85	1485032	5F	F49	2517	60	142,60	139,88	154	—	108	102	45	28,5	4,80
		34-14M-85	1485034	5F	F51	2517	60	151,52	148,79	160	—	110	102	45	28,5	6,00
		36-14M-85	1485036	5F	F52	3020	75	160,43	157,68	168	—	120	102	51	25,5	5,80
		38-14M-85	1485038	5F	F55	3020	75	169,34	166,60	184	—	130	102	51	25,5	6,80
		40-14M-85	1485040	4F	F56	3020	75	178,25	175,49	188	—	138	102	51	25,5	8,00
		44-14M-85	1485044	4F	F61	3020	75	196,08	193,28	212	—	153	102	51	25,5	11,80
		48-14M-85	1485048	4F	F62	3020	75	213,90	211,11	226	—	170	102	51	25,5	15,10
GHISA CAST IRON GRAUGUSS FONTE HIERRO FUNDIDO	SENZA FLANGIA WITHOUT FLANGES OHNE FLANSCHEN SANS FLASQUES SIN TAPETAS	56-14M-85	1485056	4F	F66	3525	90	249,55	246,76	256	190	210	102	65	18,5	19,00
		64-14M-85	1485064	9WF	F70	3525	90	285,21	282,41	296	190	240	102	65	18,5	23,00
		72-14M-85	1485072	9W		3525	90	320,86	318,06	—	190	280	102	65	18,5	25,00
		80-14M-85	1485080	9A		3525	90	356,51	353,71	—	190	315	102	65	18,5	26,00
		90-14M-85	1485090	9A		3525	90	401,07	398,28	—	190	360	102	65	18,5	27,80
		112-14M-85	1485112	9A		3525	90	499,11	496,32	—	190	457	102	65	18,5	36,50
		144-14M-85	1485144	9A		3525	90	641,71	638,92	—	190	600	102	65	18,5	48,00
		168-14M-85	1485168	9A		3525	90	748,66	745,87	—	190	706	102	65	18,5	60,00
		192-14M-85	1485192	3A		4040	100	855,62	852,82	—	190	813	102	102	—	86,00
		216-14M-85	1485216	3A		4040	100	962,57	959,76	—	190	920	102	102	—	91,50

Pulegge dentate HTD® per bussola conica
HTD® Timing belt pulleys for taper bushes
HTD® Zahnriemenscheiben für Spannbüchsen
Poulies dentées HTD® pour moyeux amovibles
Poleas dentadas HTD® para casquillos cónicos

HTD® 14M-115

CARATTERISTICHE FEATURES MERKMALE CARACTERISTIQUES CARACTERISTICAS		CODICE CODE SYMBOL FABRIKNUMMER CODE SYMBOLE NUMERO DE FABRICA	NOSTRO CODICE OUR CODE UNSER KODE NOTRE CODE NUESTRO CODIGO	TIPO TYPE TYP TYPE TIPO	TIPO FLANGIA FLANGES TYPE BORDSCHEIBEN TYP TYPE FLASQUES TIPO TAPETAS	BUSSOLA BUSH BUCHSE MOYEU CASQUILLO	FORO MAX. MAX. BORE MAX. BOHRUNG ALESAGE MAX. AGUJERO MAX.	Dp	De	Df	Dm	Di	F	S	R	PESO WEIGHT GEWICHT POIDS PESO Kg
ACCIAIO STEEL STAHL ACIER ACERO	CON FLANGIA WITH FLANGES MIT FLANGES AVEC FLASQUES CON TAPETAS	28-14M-115	1411028	4F	F40	2517	60	124,78	122,12	128	—	98	133	45	44	3,77
		29-14M-115	1411029	4F	F43	2517	60	129,23	126,57	138	—	100	133	45	44	4,00
		30-14M-115	1411030	4F	F43	2517	60	133,69	130,99	138	—	100	133	45	44	5,00
		32-14M-115	1411032	4F	F49	2517	60	142,60	139,88	154	—	108	133	45	44	6,80
		34-14M-115	1411034	4F	F51	2517	60	151,52	148,79	160	—	110	133	45	44	6,80
		36-14M-115	1411036	4F	F52	3020	75	160,43	157,68	168	—	125	133	51	41	7,00
		38-14M-115	1411038	4F	F55	3020	75	169,34	166,60	184	—	130	133	51	41	8,40
		40-14M-115	1411040	4F	F56	3020	75	178,25	175,49	188	—	138	133	51	41	9,20
		44-14M-115	1411044	4F	F61	3030	75	196,08	193,28	212	—	155	133	76	28,5	14,00
		48-14M-115	1411048	4F	F62	3030	75	213,90	211,11	226	—	170	133	76	28,5	17,10
	56-14M-115	1411056	4F	F66	3535	90	249,55	246,76	256	—	208	133	89	22	24,80	
	64-14M-115	1411064	9WF	F70	3535	90	285,21	282,41	296	190	240	133	89	22	27,00	
GHISA CAST IRON GRAUGUSS FONTE HIERRO FUNDIDO	SENZA FLANGIA WITHOUT FLANGES OHNE FLANSCHEN SANS FLASQUES SIN TAPETAS	72-14M-115	1411072	9W		3535	90	320,86	318,06	—	190	280	133	89	22	29,00
		80-14M-115	1411080	9A		3535	90	356,51	353,71	—	190	315	133	89	22	32,00
		90-14M-115	1411090	9A		3535	90	401,07	398,28	—	190	360	133	89	22	36,50
		112-14M-115	1411112	9A		3535	90	499,11	496,32	—	190	457	133	89	22	46,00
		144-14M-115	1411144	9A		4040	100	641,71	638,92	—	230	600	133	102	15,5	68,00
		168-14M-115	1411168	9A		4040	100	748,66	745,87	—	230	706	133	102	15,5	82,60
		192-14M-115	1411192	9A		4040	100	855,62	852,82	—	230	813	133	102	15,5	96,00
		216-14M-115	1411216	9A		4040	100	962,57	959,76	—	230	920	133	102	15,5	107,00

HTD® 14M-170

CARATTERISTICHE FEATURES MERKMALE CARACTERISTIQUES CARACTERISTICAS		CODICE CODE SYMBOL FABRIKNUMMER CODE SYMBOLE NUMERO DE FABRICA	NOSTRO CODICE OUR CODE UNSER KODE NOTRE CODE NUESTRO CODIGO	TIPO TYPE TYP TYPE TIPO	TIPO FLANGIA FLANGES TYPE BORDSCHEIBEN TYP TYPE FLASQUES TIPO TAPETAS	BUSSOLA BUSH BUCHSE MOYEU CASQUILLO	FORO MAX. MAX. BORE MAX. BOHRUNG ALESAGE MAX. AGUJERO MAX.	Dp	De	Df	Dm	Di	F	S	R	PESO WEIGHT GEWICHT POIDS PESO Kg
ACCIAIO STEEL STAHL ACIER ACERO	CON FLANGIA WITH FLANGES MIT FLANGES AVEC FLASQUES CON TAPETAS	38-14M-170	1417038	4F	F55	3030	75	169,34	166,60	184	—	130	187	76	55,5	11,70
		40-14M-170	1417040	4F	F56	3030	75	178,25	175,49	188	—	138	187	76	55,5	13,00
		44-14M-170	1417044	4F	F61	3535	90	196,08	193,28	212	—	153	187	89	49	15,00
		48-14M-170	1417048	4F	F62	3535	90	213,90	211,11	226	—	170	187	89	49	19,00
		56-14M-170	1417056	4F	F66	3535	90	249,55	246,76	256	—	208	187	89	49	28,50
	64-14M-170	1417064	4F	F70	4040	100	285,21	282,41	296	—	240	187	102	42,5	41,00	
GHISA CAST IRON GRAUGUSS FONTE HIERRO FUNDIDO	SENZA FLANGIA WITHOUT FLANGES OHNE FLANSCHEN SANS FLASQUES SIN TAPETAS	72-14M-170	1417072	9W		4040	100	320,86	318,06	—	230	280	187	102	42,5	46,90
		80-14M-170	1417080	9W		4040	100	356,51	353,71	—	230	315	187	102	42,5	48,00
		90-14M-170	1417090	9A		4040	100	401,07	398,28	—	230	360	187	102	42,5	52,50
		112-14M-170	1417112	9A		5050	125	499,11	496,32	—	265	457	187	127	30	74,50
		144-14M-170	1417144	9A		5050	125	641,71	638,92	—	265	600	187	127	30	91,00
		168-14M-170	1417168	9A		5050	125	748,66	745,87	—	265	706	187	127	30	116,00
		192-14M-170	1417192	9A		5050	125	855,62	852,82	—	265	813	187	127	30	134,00
		216-14M-170	1417216	9A		5050	125	962,57	959,76	—	265	920	187	127	30	146,50

Pulegge dentate per cinghie HTD®
HTD® Timing belt pulleys
HTD® Zahnriemenscheiben
Poulies dentées HTD®
Poleas para correas dentadas HTD®

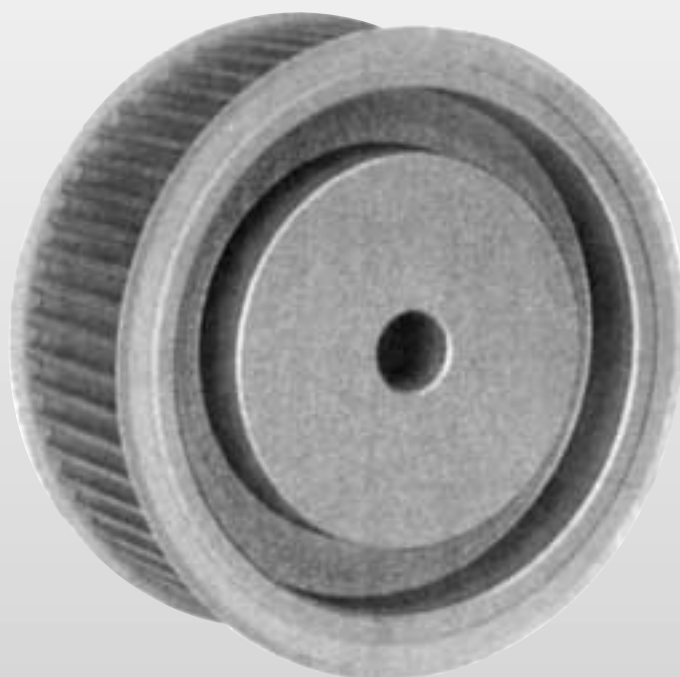

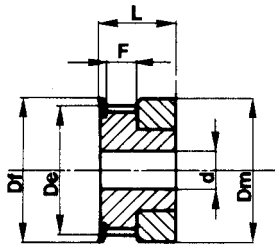

TIPO
TYPE 1F

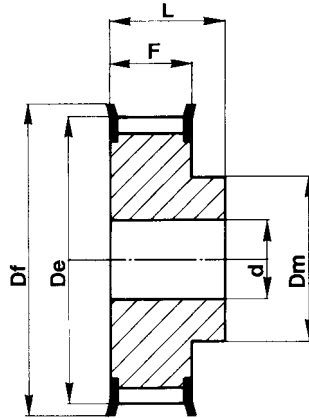

TIPO
TYPE 6F

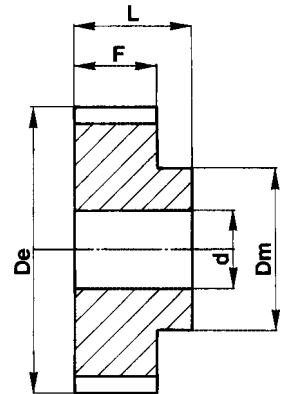

TIPO
TYPE 6

HTD® 3M-06

CARATTERISTICHE FEATURES MERKMALE CARACTERISTIQUES CARACTERÍSTICAS		CODICE CODE SYMBOL FABRIKNUMMER CODE SYMBOLE NUMERO DE FABRICA	NOSTRO CODICE OUR CODE UNSER KODE NOTRE CODE NUESTRO CODIGO	TIPO TYPE TYP TYPE TIPO	TIPO FLANGIA FLANGES TYPE BORDSCHEIBEN TYP TYPE FLASQUES TIPO TAPETAS	Dp	De	Df	Dm	F	L	FORO STOCK STOCK BORE VOR BOHRUNG ALESAGE EN STOCK AGUJERO DE STOCK	PESO WEIGHT GEWICHT POIDS PESO Kg
ALLUMINIO ALUMINIUM ALUMINIUM ALUMINIO	CON FLANGIA WITH FLANGES MIT FLANSCHEN AVEC FLASQUES CON TAPETAS	10-3M-06	03M0610	1F	F01	10	9,55	8,79	13	13	7,2	14,5	4
		12-3M-06	03M0612	1F	F02	12	11,46	10,70	15	15	7,2	14,5	4
		14-3M-06	03M0614	1F	F03	14	13,37	12,61	16	16	7,2	14,5	4
		15-3M-06	03M0615	1F	F04	15	14,32	13,56	17,5	17,5	7,2	14,5	4
		16-3M-06	03M0616	6F	F05	16	15,28	14,52	18	10	9,8	17,5	4
		18-3M-06	03M0618	6F	F06	18	17,19	16,43	20	11	9,8	17,5	6
		20-3M-06	03M0620	6F	F07	20	19,10	18,34	23	13	9,8	17,5	6
		21-3M-06	03M0621	6F	F08	21	20,05	19,29	25	13	9,8	17,5	6
		22-3M-06	03M0622	6F	F08	22	21,01	20,25	25	13	9,8	17,5	6
		24-3M-06	03M0624	6F	F08	24	22,92	22,16	25	13	9,8	17,5	6
		26-3M-06	03M0626	6F	F09	26	24,83	24,07	28	16	9,8	17,5	6
		28-3M-06	03M0628	6F	F10	28	26,74	25,98	32	18	9,8	17,5	6
		30-3M-06	03M0630	6F	F10	30	28,65	27,89	32	20	9,8	17,5	6
		32-3M-06	03M0632	6F	F12	32	30,56	29,80	36	22	9,8	17,5	6
		36-3M-06	03M0636	6F	F14	36	34,38	33,62	38	26	10,3	18	6
		40-3M-06	03M0640	6F	F15	40	38,20	37,44	42	28	10,3	18	6
		44-3M-06	03M0644	6F	F18	44	42,02	41,26	48	33	10,3	18	6
		SENZA FLANGIA WITHOUT FLANGES OHNE FLANSCHEN SANS FLASQUES SIN TAPETAS	48-3M-06	03M0648	6	48	45,84	45,08	—	33	10,3	18,6	8
60-3M-06	03M0660		6	60	57,30	56,54	—	33	10,3	18,6	8		
72-3M-06	03M0672		6	72	68,75	67,99	—	33	10,3	18,6	8		

HTD® 3M-09

CARATTERISTICHE FEATURES MERKMALE CARACTERISTIQUES CARACTERÍSTICAS		NOSTRO CODICE OUR CODE UNSER KODE NOTRE CODE NUESTRO CODIGO	CODICE SATI SATI CODE SATI FABRIKNUMMER CODE SATI NUMERO DE SATI	TIPO TYPE TYP TYPE TIPO	TIPO FLANGIA FLANGES TYPE BORDSCHEIBEN TYP TYPE FLASQUES TIPO TAPETAS		Dp	De	Df	Dm	F	L	FORO STOCK STOCK BORE VOR BOHRUNG ALESAGE EN STOCK AGUJERO DE STOCK	PESO WEIGHT GEWICHT POIDS PESO Kg
ALLUMINIO ALUMINIUM ALUMINIUM ALUMINIUM ALUMINIO	UNI 3571 TA 16 CON FLANGIA WITH FLANGES MIT FLANGES AVEC FLASQUES CON TAPETAS	10-3M-09	03M0910	1F	F01	10	9,55	8,79	13	13	10,2	17,5	4	0,004
		12-3M-09	03M0912	1F	F02	12	11,46	10,70	15	15	10,2	17,5	4	0,006
		14-3M-09	03M0914	1F	F03	14	13,37	12,61	16	16	10,2	17,5	4	0,007
		15-3M-09	03M0915	1F	F04	15	14,32	13,56	17,5	17,5	10,2	17,5	4	0,008
		16-3M-09	03M0916	6F	F05	16	15,28	14,52	18	10	12,8	20,6	4	0,007
		18-3M-09	03M0918	6F	F06	18	17,19	16,43	20	11	12,8	20,6	6	0,008
		20-3M-09	03M0920	6F	F07	20	19,10	18,34	23	13	12,8	20,6	6	0,010
		21-3M-09	03M0921	6F	F08	21	20,05	19,29	25	13	12,8	20,6	6	0,013
		22-3M-09	03M0922	6F	F08	22	21,01	20,25	25	13	12,8	20,6	6	0,014
		24-3M-09	03M0924	6F	F08	24	22,92	22,16	25	13	12,8	20,6	6	0,016
		26-3M-09	03M0926	6F	F09	26	24,83	24,07	28	16	12,8	20,6	6	0,018
		28-3M-09	03M0928	6F	F10	28	26,74	25,98	32	18	12,8	20,6	6	0,024
		30-3M-09	03M0930	6F	F10	30	28,65	27,89	32	20	12,8	20,6	6	0,028
		32-3M-09	03M0932	6F	F12	32	30,56	29,80	36	22	12,8	20,6	6	0,032
		36-3M-09	03M0936	6F	F14	36	34,38	33,62	38	26	13,4	22,2	6	0,045
		40-3M-09	03M0940	6F	F15	40	38,20	37,44	42	28	13,4	22,2	6	0,055
		44-3M-09	03M0944	6F	F18	44	42,02	41,26	48	33	13,4	22,2	6	0,074
		ALLUMINIO ALUMINIUM ALUMINIUM ALUMINIUM ALUMINIO	SENZA FLANGIA WITHOUT FLANGES OHNE FLANSCHEN SANS FLASQUES SIN TAPETAS	48-3M-09	03M0948	6		48	45,84	45,08	—	33	13,4	22,2
60-3M-09	03M0960			6		60	57,30	56,54	—	33	13,4	22,2	8	0,106
72-3M-09	03M0972			6		72	68,75	67,99	—	33	13,4	22,2	8	0,145

HTD® 3M-15

CARATTERISTICHE FEATURES MERKMALE CARACTERISTIQUES CARACTERÍSTICAS		NOSTRO CODICE OUR CODE UNSER KODE NOTRE CODE NUESTRO CODIGO	CODICE SATI SATI CODE SATI FABRIKNUMMER CODE SATI NUMERO DE SATI	TIPO TYPE TYP TYPE TIPO	TIPO FLANGIA FLANGES TYPE BORDSCHEIBEN TYP TYPE FLASQUES TIPO TAPETAS	N. DENTI N. OF TEETH ZAHNEZAHL N. BRE DE DENTS CANTIDAD DE DIENTES	Dp	De	Df	Dm	F	L	FORO STOCK STOCK BORE VOR BOHRUNG ALESAGE EN STOCK AGUJERO DE STOCK	PESO WEIGHT GEWICHT POIDS PESO Kg
ALLUMINIO ALUMINIUM ALUMINIUM ALUMINIUM ALUMINIO	UNI 3571 TA 16 CON FLANGIA WITH FLANGES MIT FLANGES AVEC FLASQUES CON TAPETAS	10-3M-15	03M1510	1F	F01	10	9,55	8,79	13	13	17	26	4	0,006
		12-3M-15	03M1512	1F	F02	12	11,46	10,70	15	15	17	26	4	0,008
		14-3M-15	03M1514	1F	F03	14	13,37	12,61	16	16	17	26	4	0,010
		15-3M-15	03M1515	1F	F04	15	14,32	13,56	17,5	17,5	17	26	4	0,012
		16-3M-15	03M1516	6F	F05	16	15,28	14,52	18	10	19,5	26	4	0,010
		18-3M-15	03M1518	6F	F06	18	17,19	16,43	20	11	19,5	26	6	0,012
		20-3M-15	03M1520	6F	F07	20	19,10	18,34	23	12	19,5	26	6	0,014
		21-3M-15	03M1521	6F	F08	21	20,05	19,29	25	13	19,5	26	6	0,016
		22-3M-15	03M1522	6F	F08	22	21,01	20,25	25	13	19,5	26	6	0,018
		24-3M-15	03M1524	6F	F08	24	22,92	22,16	25	13	19,5	26	6	0,020
		26-3M-15	03M1526	6F	F09	26	24,83	24,07	28	16	19,5	26	6	0,027
		28-3M-15	03M1528	6F	F10	28	26,74	25,98	32	18	19,5	26	6	0,030
		30-3M-15	03M1530	6F	F10	30	28,65	27,89	32	20	19,5	26	6	0,035
		32-3M-15	03M1532	6F	F12	32	30,56	29,80	36	22	19,5	26	6	0,042
		36-3M-15	03M1536	6F	F14	36	34,38	33,62	38	26	20	30	6	0,060
		40-3M-15	03M1540	6F	F15	40	38,20	37,44	42	28	20	30	6	0,075
		44-3M-15	03M1544	6F	F18	44	42,02	41,26	48	33	20	30	6	0,095
		ALLUMINIO ALUMINIUM ALUMINIUM ALUMINIUM ALUMINIO	SENZA FLANGIA WITHOUT FLANGES OHNE FLANSCHEN SANS FLASQUES SIN TAPETAS	48-3M-15	03M1548	6		48	45,84	45,08	—	33	20	30
60-3M-15	03M1560			6		60	57,30	56,54	—	33	20	30	8	0,150
72-3M-15	03M1572			6		72	68,75	67,99	—	33	20	30	8	0,212

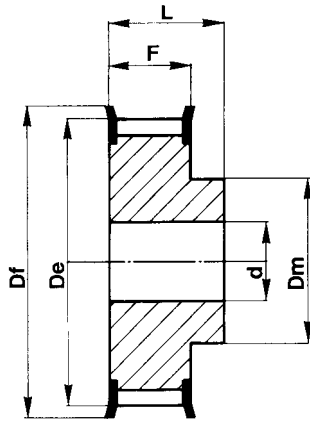

TIPO 6F
TYPE 6F

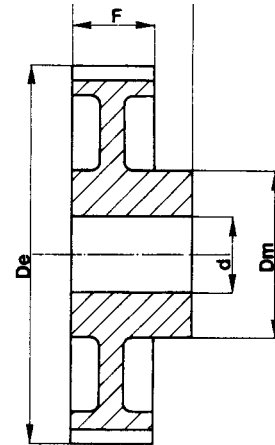

TIPO 6W
TYPE 6W

HTD® 5M-09

CARATTERISTICHE FEATURES MERKMALE CARACTERISTIQUES CARACTERÍSTICAS		CODICE CODE SYMBOL FABRIKNUMMER CODE SYMBOLE NUMERO DE FABRICA	NOSTRO CODICE OUR CODE UNSER KODE NOTRE CODE NUESTRO CODIGO	TIPO TYPE TYP TYPE TIPO	TIPO FLANGIA FLANGES TYPE BORDSCHEIBEN TYP TYPE FLASQUES TIPO TAPETAS	N. DENTI N. OF TEETH ZAHNEZAHL N. BRE DE DENTS CANTIDAD DE DIENTES	Dp	De	Df	Dm	Di	F	L	FORO STOCK STOCK BORE VOR BOHRUNG ALESAGE EN STOCK AGUJERO DE STOCK	PESO WEIGHT GEWICHT POIDS PESO Kg
ACCIAIO STEEL STAHL ACIER ACERO	CON FLANGIA WITH FLANGES MIT FLANGES AVEC FLASQUES CON TAPETAS	12-5M-09	05M0912	6F	F07	12	19,10	17,96	23	12	—	14,5	20	4	0,028
		14-5M-09	05M0914	6F	F08	14	22,28	21,14	25	13	—	14,5	20	6	0,034
		15-5M-09	05M0915	6F	F09	15	23,87	22,73	28	16	—	14,5	20	6	0,042
		16-5M-09	05M0916	6F	F09	16	25,46	24,32	28	16,5	—	14,5	20	6	0,050
		18-5M-09	05M0918	6F	F10	18	28,65	27,51	32	20	—	14,5	20	6	0,070
		20-5M-09	05M0920	6F	F12	20	31,83	30,69	36	23	—	14,5	22,5	6	0,094
		21-5M-09	05M0921	6F	F14	21	33,42	32,28	38	24	—	14,5	22,5	6	0,110
		22-5M-09	05M0922	6F	F14	22	35,01	33,87	38	25,5	—	14,5	22,5	6	0,118
		24-5M-09	05M0924	6F	F15	24	38,20	37,06	42	27	—	14,5	22,5	6	0,145
		26-5M-09	05M0926	6F	F17	26	41,38	40,24	44	30	—	14,5	22,5	6	0,170
		28-5M-09	05M0928	6F	F18	28	44,56	43,42	48	30,5	—	14,5	22,5	6	0,200
		30-5M-09	05M0930	6F	F19	30	47,75	46,60	51	35	—	14,5	22,5	6	0,236
		32-5M-09	05M0932	6F	F20	32	50,93	49,79	54	38	—	14,5	22,5	8	0,210
		36-5M-09	05M0936	6F	F22	36	57,30	56,16	60	38	—	14,5	22,5	8	0,324
		40-5M-09	05M0940	6F	F26	40	63,66	62,52	70	38	—	14,5	22,5	8	0,400
		ALLUMINIO ALUMINIUM ALUMINIUM ALUMINIUM ALUMINIO	SENZA FLANGIA WITHOUT FLANGES OHNE FLANSCHEN SANS FLASQUES SIN TAPETAS	44-5M-09	05M0944	6W		44	70,03	68,89	—	38	54	14,5	25,5
48-5M-09	05M0948			6W		48	76,39	75,25	—	45	61	14,5	25,5	8	0,182
60-5M-09	05M0960			6W		60	95,46	94,35	—	45	80	14,5	25,5	8	0,230
72-5M-09	05M0972			6W		72	114,59	113,45	—	45	100	14,5	25,5	8	0,270

HTD® 5M-15

CARATTERISTICHE FEATURES MERKMALE CARACTERISTIQUES CARACTERÍSTICAS		CODICE CODE SYMBOL FABRIKNUMMER CODE SYMBOLE NUMERO DE FABRICA	NOSTRO CODICE OUR CODE UNSER KODE NOTRE CODE NUESTRO CODIGO	TIPO TYPE TYP TYPE TIPO	TIPO FLANGIA FLANGES TYPE BORDSCHEIBEN TYP TYPE FLASQUES TIPO TAPETAS	N.DENTI N. OF TEETH ZAHNEZAHL N. BRE DE DENTS CANTIDAD DE DIENTES	Dp	De	Df	Dm	Di	F	L	FORO STOCK STOCK BORE VOR BOHRUNG ALESAGE EN STOCK AGUJERO DE STOCK	PESO WEIGHT GEWICHT POIDS PESO Kg
ACCIAIO STEEL STAHL ACIER ACERO	CON FLANGIA WITH FLANGES MIT FLANSCHEN AVEC FLASQUES CON TAPETAS	12-5M-15	05M1512	6F	F07	12	19,10	17,96	23	12	—	20,5	26	4	0,034
		14-5M-15	05M1514	6F	F08	14	22,28	21,14	25	13	—	20,5	26	6	0,046
		15-5M-15	05M1515	6F	F09	15	23,87	22,73	28	16	—	20,5	26	6	0,056
		16-5M-15	05M1516	6F	F09	16	25,46	24,32	28	16,5	—	20,5	26	6	0,064
		18-5M-15	05M1518	6F	F10	18	28,65	27,51	32	20	—	20,5	26	6	0,086
		20-5M-15	05M1520	6F	F12	20	31,83	30,69	36	23	—	20,5	26	6	0,112
		21-5M-15	05M1521	6F	F14	21	33,42	32,28	38	24	—	20,5	26	6	0,130
		22-5M-15	05M1522	6F	F14	22	35,01	33,87	38	25,5	—	20,5	26	6	0,140
		24-5M-15	05M1524	6F	F15	24	38,20	37,06	42	27	—	20,5	28	6	0,180
		26-5M-15	05M1526	6F	F17	26	41,38	40,24	44	30	—	20,5	28	6	0,220
		28-5M-15	05M1528	6F	F18	28	44,56	43,42	48	30,5	—	20,5	28	6	0,250
		30-5M-15	05M1530	6F	F19	30	47,75	46,60	51	35	—	20,5	28	6	0,300
		32-5M-15	05M1532	6F	F20	32	50,93	49,79	54	38	—	20,5	28	8	0,350
		36-5M-15	05M1536	6F	F24	36	57,30	56,16	60	38	—	20,5	28	8	0,426
40-5M-15	05M1540	6F	F26	40	63,66	62,52	70	38	—	20,5	28	8	0,520		
ALLUMINIO ALUMINIUM ALUMINIUM ALUMINIUM ALUMINIO	SENZA FLANGIA WITHOUT FLANGES OHNE FLANSCHEN SANS FLASQUES SIN TAPETAS	44-5M-15	05M1544	6W		44	70,03	68,89	—	38	54	20,5	30	8	0,225
		48-5M-15	05M1548	6W		48	76,39	75,25	—	45	61	20,5	30	8	0,187
		60-5M-15	05M1560	6W		60	95,46	94,35	—	45	80	20,5	30	8	0,305
		72-5M-15	05M1572	6W		72	114,59	113,45	—	45	100	20,5	30	8	0,305

HTD® 5M-25

CARATTERISTICHE FEATURES MERKMALE CARACTERISTIQUES CARACTERÍSTICAS		CODICE CODE SYMBOL FABRIKNUMMER CODE SYMBOLE NUMERO DE FABRICA	NOSTRO CODICE OUR CODE UNSER KODE NOTRE CODE NUESTRO CODIGO	TIPO TYPE TYP TYPE TIPO	TIPO FLANGIA FLANGES TYPE BORDSCHEIBEN TYP TYPE FLASQUES TIPO TAPETAS	N.DENTI N. OF TEETH ZAHNEZAHL N. BRE DE DENTS CANTIDAD DE DIENTES	Dp	De	Df	Dm	Di	F	L	FORO STOCK STOCK BORE VOR BOHRUNG ALESAGE EN STOCK AGUJERO DE STOCK	PESO WEIGHT GEWICHT POIDS PESO Kg
ACCIAIO STEEL STAHL ACIER ACERO	CON FLANGIA WITH FLANGES MIT FLANSCHEN AVEC FLASQUES CON TAPETAS	12-5M-25	05M2512	6F	F07	12	19,10	17,96	23	12	—	30,5	36	4	0,050
		14-5M-25	05M2514	6F	F08	14	22,28	21,14	25	13	—	30,5	36	6	0,070
		15-5M-25	05M2515	6F	F09	15	23,87	22,73	28	16	—	30,5	36	6	0,080
		16-5M-25	05M2516	6F	F09	16	25,46	24,32	28	16,5	—	30,5	36	6	0,100
		18-5M-25	05M2518	6F	F10	18	28,65	27,51	32	20	—	30,5	36	6	0,120
		20-5M-25	05M2520	6F	F12	20	31,83	30,69	36	23	—	30,5	36,5	6	0,160
		21-5M-25	05M2521	6F	F14	21	33,42	32,28	38	24	—	30,5	38,5	6	0,190
		22-5M-25	05M2522	6F	F14	22	35,01	33,87	38	25,5	—	30,5	38,5	6	0,210
		24-5M-25	05M2524	6F	F15	24	38,20	37,06	42	27	—	30,5	38,5	6	0,250
		26-5M-25	05M2526	6F	F17	26	41,38	40,24	44	30	—	30,5	38,5	6	0,300
		28-5M-25	05M2528	6F	F18	28	44,56	43,42	48	30,5	—	30,5	38,5	6	0,350
		30-5M-25	05M2530	6F	F19	30	47,75	46,60	51	35	—	30,5	38,5	6	0,420
		32-5M-25	05M2532	6F	F20	32	50,93	49,79	54	38	—	30,5	38,5	8	0,480
		36-5M-25	05M2536	6F	F22	36	57,30	56,16	60	38	—	30,5	38,5	8	0,590
40-5M-25	05M2540	6F	F26	40	63,66	62,52	70	38	—	30,5	38,5	8	0,740		
ALLUMINIO ALUMINIUM ALUMINIUM ALUMINIUM ALUMINIO	SENZA FLANGIA WITHOUT FLANGES OHNE FLANSCHEN SANS FLASQUES SIN TAPETAS	44-5M-25	05M2544	6W		44	70,03	68,89	—	38	54	30,5	40,5	8	0,320
		48-5M-25	05M2548	6W		48	76,39	75,25	—	45	61	30,5	40,5	8	0,275
		60-5M-25	05M2560	6W		60	95,46	94,35	—	45	80	30,5	40,5	8	0,435
		72-5M-25	05M2572	6W		72	114,59	113,45	—	45	100	30,5	40,5	8	0,525

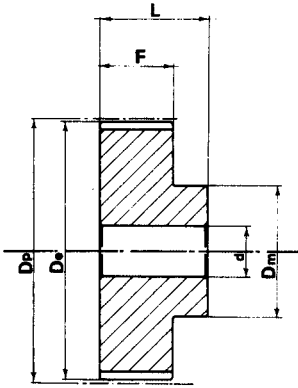

TIPO
TYPE 6

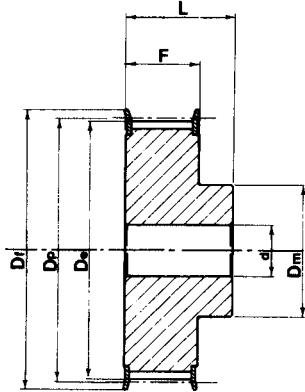

TIPO
TYPE 6F

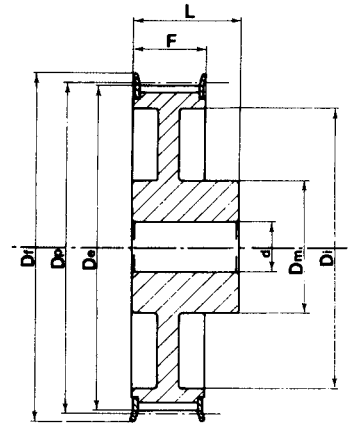

TIPO
TYPE 6WF

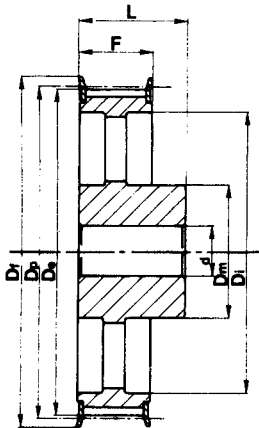

TIPO
TYPE 6AF

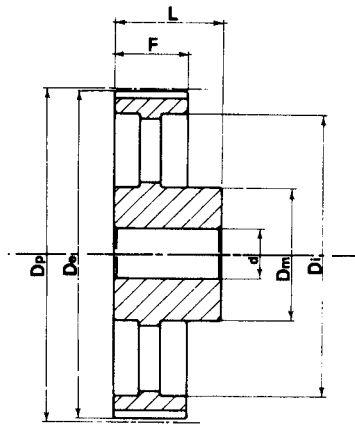

TIPO
TYPE 6A

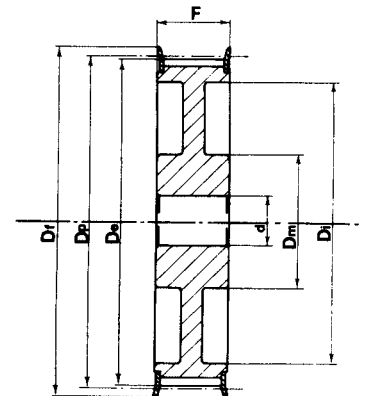

TIPO
TYPE 10WF

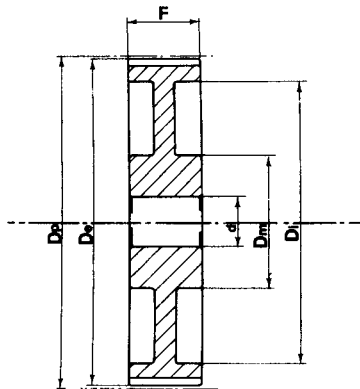

TIPO
TYPE 10W

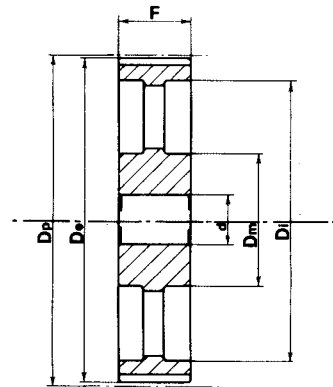

TIPO
TYPE 10A

HTD® 8M-20

CARATTERISTICHE FEATURES MERKMALE CARACTERISTIQUES CARACTERÍSTICAS		CODICE CODE SYMBOL FABRIKNUMMER CODE SYMBOLE NUMERO DE FABRICA	NOSTRO CODICE OUR CODE UNSER KODE NOTRE CODE NUESTRO CODIGO	TIPO TYPE TYP TYPE TIPO	TIPO FLANGIA FLANGES TYPE BORDSCHEIBEN TYP TYPE FLASQUES TIPO TAPETAS	N.DENTI N. OF TEETH ZAHNEZAHL N. BRE DE DENTS CANTIDAD DE DIENTES	Dp	De	Df	Dm	Di	F	L	d	PESO WEIGHT GEWICHT POIDS PESO Kg
ACCIAIO STEEL STAHL ACIER ACERO	CON FLANGIA WITH FLANGES MIT FLANGES AVEC FLASQUES CON TAPETAS	22-8M-20	08M2022	6F	F22	22	56,02	54,65	60	43	—	28	38	12	0,54
		24-8M-20	08M2024	6F	F25	24	61,12	59,75	66	45	—	28	38	12	0,65
		26-8M-20	08M2026	6F	F26	26	66,21	64,84	70	48	—	28	38	12	0,80
		28-8M-20	08M2028	6F	F27	28	71,30	70,08	75	50	—	28	38	15	0,87
		30-8M-20	08M2030	6F	F29	30	76,39	75,13	83	55	—	28	38	15	1,02
		32-8M-20	08M2032	6F	F30	32	81,49	80,16	87	60	—	28	38	15	1,20
		34-8M-20	08M2034	6F	F31	34	86,58	85,22	91	70	—	28	38	15	1,40
		36-8M-20	08M2036	6F	F33	36	91,67	90,30	97	75	—	28	38	15	1,55
		38-8M-20	08M2038	6F	F34	38	96,77	95,39	102	75	—	28	38	15	1,65
		40-8M-20	08M2040	6F	F35	40	101,86	100,49	106	75	—	28	38	15	1,74
		44-8M-20	08M2044	6F	F38	44	112,05	110,67	120	75	—	28	38	15	2,10
		48-8M-20	08M2048	6F	F40	48	122,23	120,86	128	75	—	28	38	15	2,44
		56-8M-20	08M2056	6WF	F48	56	142,60	141,23	150	80	116	28	38	15	2,60
64-8M-20	08M2064	6WF	F52	64	162,97	161,60	168	80	137	28	38	15	2,90		
72-8M-20	08M2072	6WF	F57	72	183,35	181,97	192	80	158	28	38	15	3,10		
GHISA CAST IRON GRAUGUSS FONTE HIERRO FUNDIDO	SENZA FLANGIA WITHOUT FLANGES OHNE FLANSCHEN SANS FLASQUES SIN TAPETAS	80-8M-20	08M2080	6W		80	203,72	202,35	—	90	180	28	38	15	3,80
		90-8M-20	08M2090	6A		90	229,18	227,81	—	90	204	28	38	15	4,20
		112-8M-20	8M20112	6A		112	285,21	283,83	—	90	254	28	38	18	5,20
		144-8M-20	8M20144	6A		144	366,69	365,32	—	90	336	28	38	20	7,50
		168-8M-20	8M20168	6A		168	427,81	426,44	—	100	400	28	38	20	10,00
		192-8M-20	8M20192	6A		192	488,92	487,55	—	100	460	28	38	20	14,40

HTD® 8M-30

CARATTERISTICHE FEATURES MERKMALE CARACTERISTIQUES CARACTERÍSTICAS		CODICE CODE SYMBOL FABRIKNUMMER CODE SYMBOLE NUMERO DE FABRICA	NOSTRO CODICE OUR CODE UNSER KODE NOTRE CODE NUESTRO CODIGO	TIPO TYPE TYP TYPE TIPO	TIPO FLANGIA FLANGES TYPE BORDSCHEIBEN TYP TYPE FLASQUES TIPO TAPETAS	N.DENTI N. OF TEETH ZAHNEZAHL N. BRE DE DENTS CANTIDAD DE DIENTES	Dp	De	Df	Dm	Di	F	L	d	PESO WEIGHT GEWICHT POIDS PESO Kg
ACCIAIO STEEL STAHL ACIER ACERO	CON FLANGIA WITH FLANGES MIT FLANGES AVEC FLASQUES CON TAPETAS	22-8M-30	08M3022	6F	F22	22	56,02	54,65	60	43	—	38	48	12	0,69
		24-8M-30	08M3024	6F	F25	24	61,12	59,75	66	45	—	38	48	12	0,84
		26-8M-30	08M3026	6F	F26	26	66,21	64,84	70	48	—	38	48	12	1,00
		28-8M-30	08M3028	6F	F27	28	71,30	70,08	75	50	—	38	48	15	1,12
		30-8M-30	08M3030	6F	F29	30	76,39	75,13	83	55	—	38	48	15	1,32
		32-8M-30	08M3032	6F	F30	32	81,49	80,16	87	60	—	38	48	15	1,53
		34-8M-30	08M3034	6F	F31	34	86,58	85,22	91	70	—	38	48	15	1,80
		36-8M-30	08M3036	6F	F33	36	91,67	90,30	97	75	—	38	48	15	1,99
		38-8M-30	08M3038	6F	F34	38	96,77	95,39	102	75	—	38	48	15	2,27
		40-8M-30	08M3040	6F	F35	40	101,86	100,49	106	75	—	38	48	15	2,40
		44-8M-30	08M3044	6F	F38	44	112,05	110,67	120	75	—	38	48	15	2,80
		48-8M-30	08M3048	6F	F40	48	122,23	120,86	128	75	—	38	48	15	3,20
		56-8M-30	08M3056	6WF	F48	56	142,60	141,23	150	90	116	38	48	15	3,60
64-8M-30	08M3064	6WF	F52	64	162,97	161,60	168	90	137	38	48	15	4,30		
72-8M-30	08M3072	6WF	F57	72	183,35	181,97	192	95	158	38	48	15	4,80		
GHISA CAST IRON GRAUGUSS FONTE HIERRO FUNDIDO	SENZA FLANGIA WITHOUT FLANGES OHNE FLANSCHEN SANS FLASQUES SIN TAPETAS	80-8M-30	08M3080	6W		80	203,72	202,35	—	100	180	38	48	15	5,10
		90-8M-30	08M3090	6A		90	229,18	227,81	—	100	204	38	48	15	5,70
		112-8M-30	08M3011	6A		112	285,21	283,83	—	100	254	38	48	18	6,80
		144-8M-30	08M3014	6A		144	366,69	365,32	—	100	336	38	48	20	9,30
		168-8M-30	08M3016	6A		168	427,81	426,44	—	100	400	38	48	20	11,40
		192-8M-30	08M3019	6A		192	488,92	487,55	—	100	460	38	48	20	16,00

HTD® 8M-50

CARATTERISTICHE FEATURES MERKMALE CARACTERISTIQUES CARACTERÍSTICAS		CODICE CODE SYMBOL FABRIKNUMMER CODE SYMBOLE NUMERO DE FABRICA	NOSTRO CODICE OUR CODE UNSER KODE NOTRE CODE NUESTRO CODIGO	TIPO TYPE TYP TYPE TIPO	TIPO FLANGIA FLANGES TYPE BORDSCHEIBEN TYP TYPE FLASQUES TIPO TAPETAS	N.DENTI N. OF TEETH ZAHNEZAHL N. BRE DE DENTS CANTIDAD DE DIENTES	Dp	De	Df	Dm	Di	F	L	d	PESO WEIGHT GEWICHT POIDS PESO Kg
ACCIAIO STEEL STAHL ACIER ACERO	CON FLANGIA WITH FLANGES MIT FLANGES AVEC FLASQUES CON TAPETAS	22-8M-50	08M5022	6F	F22	22	56,02	54,65	60	43	—	60	70	12	1,00
		24-8M-50	08M5024	6F	F25	24	61,12	59,75	66	45	—	60	70	12	1,23
		26-8M-50	08M5026	6F	F26	26	66,21	64,84	70	48	—	60	70	15	1,50
		28-8M-50	08M5028	6F	F27	28	71,30	70,08	75	50	—	60	70	15	1,67
		30-8M-50	08M5030	6F	F29	30	76,39	75,13	83	55	—	60	70	15	1,97
		32-8M-50	08M5032	6F	F30	32	81,49	80,16	87	60	—	60	70	15	2,27
		34-8M-50	08M5034	6F	F31	34	86,58	85,22	91	66	—	60	70	15	2,69
		36-8M-50	08M5036	6F	F33	36	91,67	90,30	97	70	—	60	70	15	2,97
		38-8M-50	08M5038	6F	F34	38	96,77	95,39	102	75	—	60	70	15	3,23
		40-8M-50	08M5040	6F	F35	40	101,86	100,49	106	75	—	60	70	18	3,50
		44-8M-50	08M5044	6F	F38	44	112,05	110,67	120	75	—	60	70	18	3,90
		48-8M-50	08M5048	6F	F40	48	122,23	120,86	128	80	—	60	70	18	4,30
		56-8M-50	08M5056	10WF	F48	56	142,60	141,23	150	90	116	60	60	18	5,00
		64-8M-50	08M5064	10WF	F52	64	162,97	161,60	168	100	137	60	60	18	5,60
72-8M-50	08M5072	10WF	F57	72	183,35	181,97	192	100	158	60	60	18	6,80		
GHISA CAST IRON GRAUGUSS FONTE HIERRO FUNDIDO	SENZA FLANGIA WITHOUT FLANGES OHNE FLANSCHEN SANS FLASQUES SIN TAPETAS	80-8M-50	08M5080	10W		80	203,72	202,35	—	110	180	60	60	18	6,90
		90-8M-50	08M5090	10A		90	229,18	227,81	—	110	204	60	60	18	8,60
		112-8M-50	08M5011	10A		112	285,21	283,83	—	110	254	60	60	18	9,60
		144-8M-50	08M5014	10A		144	366,69	365,32	—	110	336	60	60	20	13,80
		168-8M-50	08M5016	10A		168	427,81	426,44	—	120	400	60	60	20	16,00
		192-8M-50	08M5019	10A		192	488,92	487,55	—	130	460	60	60	20	22,40

HTD® 8M-85

CARATTERISTICHE FEATURES MERKMALE CARACTERISTIQUES CARACTERÍSTICAS		CODICE CODE SYMBOL FABRIKNUMMER CODE SYMBOLE NUMERO DE FABRICA	NOSTRO CODICE OUR CODE UNSER KODE NOTRE CODE NUESTRO CODIGO	TIPO TYPE TYP TYPE TIPO	TIPO FLANGIA FLANGES TYPE BORDSCHEIBEN TYP TYPE FLASQUES TIPO TAPETAS	N.DENTI N. OF TEETH ZAHNEZAHL N. BRE DE DENTS CANTIDAD DE DIENTES	Dp	De	Df	Dm	Di	F	L	d	PESO WEIGHT GEWICHT POIDS PESO Kg
ACCIAIO STEEL STAHL ACIER ACERO	CON FLANGIA WITH FLANGES MIT FLANGES AVEC FLASQUES CON TAPETAS	22-8M-85	08M8522	6F	F22	22	56,02	54,65	60	43	—	95	105	12	1,55
		24-8M-85	08M8524	6F	F25	24	61,12	59,75	66	45	—	95	105	12	1,90
		26-8M-85	08M8526	6F	F26	26	66,21	64,84	70	48	—	95	105	12	2,25
		28-8M-85	08M8528	6F	F27	28	71,30	70,08	75	50	—	95	105	15	2,55
		30-8M-85	08M8530	6F	F29	30	76,39	75,13	83	55	—	95	105	15	3,00
		32-8M-85	08M8532	6F	F30	32	81,49	80,16	87	60	—	95	105	15	3,57
		34-8M-85	08M8534	6F	F31	34	86,58	85,22	91	66	—	95	105	15	4,00
		36-8M-85	08M8536	6F	F33	36	91,67	90,30	97	70	—	95	105	15	4,50
		38-8M-85	08M8538	6F	F34	38	96,77	95,39	102	75	—	95	105	15	5,00
		40-8M-85	08M8540	6F	F35	40	101,86	100,49	106	75	—	95	105	18	5,20
		44-8M-85	08M8544	6F	F38	44	112,05	110,67	120	75	—	95	105	18	6,60
		48-8M-85	08M8548	6F	F40	48	122,23	120,86	128	80	—	95	105	18	7,00
		56-8M-85	08M8556	6F	F48	56	142,60	141,23	150	90	—	95	105	18	10,00
		64-8M-85	08M8564	10WF	F52	64	162,97	161,60	168	100	137	95	95	20	10,40
72-8M-85	08M8572	10WF	F57	72	183,35	181,97	192	100	158	95	95	20	11,40		
GHISA CAST IRON GRAUGUSS FONTE HIERRO FUNDIDO	SENZA FLANGIA WITHOUT FLANGES OHNE FLANSCHEN SANS FLASQUES SIN TAPETAS	80-8M-85	08M8580	10W		80	203,72	202,35	—	110	180	95	95	20	11,10
		90-8M-85	08M8590	10A		90	229,18	227,81	—	110	204	95	95	20	12,20
		112-8M-85	08M8511	10A		112	285,21	283,83	—	110	254	95	95	24	15,00
		144-8M-85	08M8514	10A		144	366,69	365,32	—	110	336	95	95	24	21,50
		168-8M-85	08M8516	10A		168	427,81	426,44	—	120	400	95	95	24	24,10
		192-8M-85	08M8519	10A		192	488,92	487,55	—	130	460	95	95	24	30,60

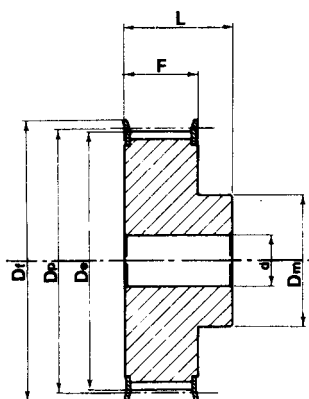

TIPO
TYPE 6F

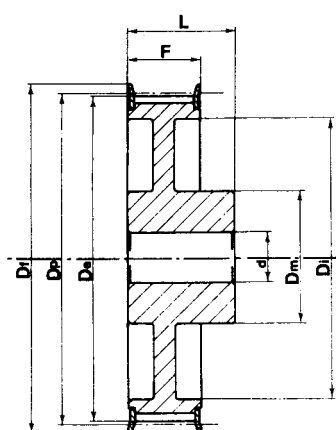

TIPO
TYPE 6WF

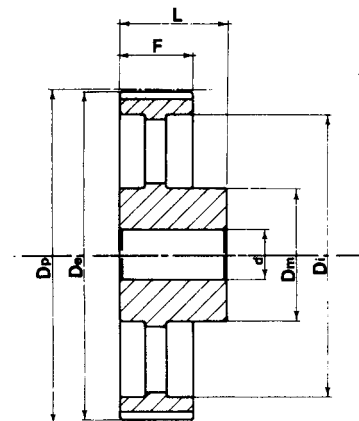

TIPO
TYPE 6A

HTD® 14M-40

CARATTERISTICHE FEATURES MERKMALE CARACTERISTIQUES CARACTERÍSTICAS		CODICE CODE SYMBOL FABRIKNUMMER CODE SYMBOLE NUMERO DE FABRICA	NOSTRO CODICE OUR CODE UNSER KODE NOTRE CODE NUESTRO CODIGO	TIPO TYPE TYP TYPE TIPO	TIPO FLANGIA FLANGES TYPE BORDSCHEIBEN TYP TYPE FLASQUES TIPO TAPETAS	N. DENTI N. OF TEETH ZAHNEZAHL N. BRE DE DENTS CANTIDAD DE DIENTES	Dp	De	Df	Dm	Di	F	L	d	PESO WEIGHT GEWICHT POIDS PESO Kg
ACCIAIO STEEL STAHL ACIER ACERO	CON FLANGIA WITH FLANGES MIT FLANSCHEN AVEC FLASQUES CON TAPETAS	28-14M-40	14M4028	6F	F40	28	124,78	122,12	128	100	—	54	69	24	4,73
		29-14M-40	14M4029	6F	F43	29	129,23	126,57	138	100	—	54	69	24	5,09
		30-14M-40	14M4030	6F	F43	30	133,69	130,99	138	100	—	54	69	24	5,45
		32-14M-40	14M4032	6F	F49	32	142,60	139,88	154	100	—	54	69	24	6,17
		34-14M-40	14M4034	6F	F51	34	151,52	148,79	160	100	—	54	69	24	6,88
		36-14M-40	14M4036	6F	F52	36	160,43	157,68	168	100	—	54	69	24	7,60
		38-14M-40	14M4038	6F	F55	38	169,34	166,60	184	120	—	54	69	24	8,28
		40-14M-40	14M4040	6F	F56	40	178,25	175,49	188	120	—	54	69	24	9,26
		44-14M-40	14M4044	6F	F61	44	196,08	193,28	212	120	—	54	69	24	10,32
		48-14M-40	14M4048	6WF	F62	48	213,90	211,11	226	135	170	54	69	24	11,50
GHISA CAST IRON GRAUGUSS FONTE HIERRO FUNDIDO	SENZA FLANGIA WITHOUT FLANGES OHNE FLANSCHEN SANS FLASQUES SIN TAPETAS	56-14M-40	14M4056	6WF	F66	56	249,55	246,76	256	135	207	54	69	28	13,05
		64-14M-40	14M4064	6WF	F70	64	285,21	282,41	296	135	240	54	69	28	14,40
		72-14M-40	14M4072	6A		72	320,86	318,06	—	135	278	54	69	28	16,90
		80-14M-40	14M4080	6A		80	356,51	353,71	—	135	314	54	69	28	18,50
		90-14M-40	14M4090	6A		90	401,07	398,28	—	135	358	54	69	28	20,00
		112-14M-40	14M4011	6A		112	499,11	496,32	—	135	456	54	69	28	26,70
		144-14M-40	14M4014	6A		144	641,71	638,92	—	135	600	54	69	28	35,00
		168-14M-40	14M4016	6A		168	748,66	745,87	—	135	706	54	69	28	44,20
		192-14M-40	14M4019	6A		192	855,62	852,82	—	135	813	54	69	28	52,20
		216-14M-40	14M4021	6A		216	962,57	959,76	—	150	920	54	69	28	62,50

HTD® 14M-55

CARATTERISTICHE FEATURES MERKMALE CARACTERISTIQUES CARACTERÍSTICAS		CODICE CODE SYMBOL FABRIKNUMMER CODE SYMBOLE NUMERO DE FABRICA	NOSTRO CODICE OUR CODE UNSER KODE NOTRE CODE NUESTRO CODIGO	TIPO TYPE TYP TYPE TIPO	TIPO FLANGIA FLANGES TYPE BORDSCHEIBEN TYP TYPE FLASQUES TIPO TAPETAS	N.DENTI N. OF TEETH ZAHNEZAHL N. BRE DE DENTS CANTIDAD DE DIENTES	Dp	De	Df	Dm	Di	F	L	d	PESO WEIGHT GEWICHT POIDS PESO Kg
ACCIAIO STEEL STAHL ACIER ACERO	CON FLANGIA WITH FLANGES MIT FLANGES AVEC FLASQUES CON TAPETAS	28-14M-55	14M5528	6F	F40	28	124,78	122,12	128	100	—	70	85	24	5,60
		29-14M-55	14M5529	6F	F43	29	129,23	126,57	138	100	—	70	85	24	6,10
		30-14M-55	14M5530	6F	F43	30	133,69	130,99	138	100	—	70	85	24	6,60
		32-14M-55	14M5532	6F	F49	32	142,60	139,88	154	100	—	70	85	24	7,60
		34-14M-55	14M5534	6F	F51	34	151,52	148,79	160	100	—	70	85	24	8,60
		36-14M-55	14M5536	6F	F52	36	160,43	157,68	168	100	—	70	85	24	9,60
		38-14M-55	14M5538	6F	F55	38	169,34	166,60	184	120	—	70	85	24	10,80
		40-14M-55	14M5540	6F	F56	40	178,25	175,49	188	120	—	70	85	24	11,20
		44-14M-55	14M5544	6F	F61	44	196,08	193,28	212	120	—	70	85	24	12,50
		48-14M-55	14M5548	10WF	F62	48	213,90	211,11	226	135	170	70	70	24	13,70
GHISA CAST IRON GRAUGUSS FONTE HIERRO FUNDIDO	SENZA FLANGIA WITHOUT FLANGES OHNE FLANSCHEN SANS FLASQUES SIN TAPETAS	56-14M-55	14M5556	10WF	F66	56	249,55	246,76	256	135	207	70	70	28	14,50
		64-14M-55	14M5564	10WF	F70	64	285,21	282,41	296	135	240	70	70	28	15,60
		72-14M-55	14M5572	10A		72	320,86	318,06	—	135	278	70	70	28	16,90
		80-14M-55	14M5580	10A		80	356,51	353,71	—	135	314	70	70	28	20,00
		90-14M-55	14M5590	10A		90	401,07	398,28	—	135	358	70	70	28	22,60
		112-14M-55	14M5511	10A		112	499,11	496,32	—	135	456	70	70	28	29,50
		144-14M-55	14M5514	10A		144	641,71	638,92	—	135	600	70	70	28	39,00
		168-14M-55	14M5516	10A		168	748,66	745,87	—	135	706	70	70	28	48,50
		192-14M-55	14M5519	10A		192	855,62	852,82	—	135	813	70	70	28	57,80
		216-14M-55	14M5521	10A		216	962,57	959,76	—	150	920	70	70	28	67,00

HTD® 14M-85

CARATTERISTICHE FEATURES MERKMALE CARACTERISTIQUES CARACTERÍSTICAS		CODICE CODE SYMBOL FABRIKNUMMER CODE SYMBOLE NUMERO DE FABRICA	NOSTRO CODICE OUR CODE UNSER KODE NOTRE CODE NUESTRO CODIGO	TIPO TYPE TYP TYPE TIPO	TIPO FLANGIA FLANGES TYPE BORDSCHEIBEN TYP TYPE FLASQUES TIPO TAPETAS	N.DENTI N. OF TEETH ZAHNEZAHL N. BRE DE DENTS CANTIDAD DE DIENTES	Dp	De	Df	Dm	Di	F	L	d	PESO WEIGHT GEWICHT POIDS PESO Kg
ACCIAIO STEEL STAHL ACIER ACERO	CON FLANGIA WITH FLANGES MIT FLANGES AVEC FLASQUES CON TAPETAS	28-14M-85	14M8528	6F	F40	28	124,78	122,12	128	100	—	102	117	24	7,70
		29-14M-85	14M8529	6F	F43	29	129,23	126,57	138	100	—	102	117	24	8,40
		30-14M-85	14M8530	6F	F43	30	133,69	130,99	138	100	—	102	117	24	9,10
		32-14M-85	14M8532	6F	F49	32	142,60	139,88	154	100	—	102	117	24	10,50
		34-14M-85	14M8534	6F	F51	34	151,52	148,79	160	100	—	102	117	24	11,90
		36-14M-85	14M8536	6F	F52	36	160,43	157,68	168	100	—	102	117	32	13,20
		38-14M-85	14M8538	6F	F55	38	169,34	166,60	184	120	—	102	117	32	15,15
		40-14M-85	14M8540	6F	F56	40	178,25	175,49	188	135	—	102	117	32	17,10
		44-14M-85	14M8544	6F	F61	44	196,08	193,28	212	135	—	102	117	32	23,30
		48-14M-85	14M8548	6F	F62	48	213,90	211,11	226	150	—	102	117	32	25,00
GHISA CAST IRON GRAUGUSS FONTE HIERRO FUNDIDO	SENZA FLANGIA WITHOUT FLANGES OHNE FLANSCHEN SANS FLASQUES SIN TAPETAS	56-14M-85	14M8556	10WF	F66	56	249,55	246,76	256	150	207	102	117	32	25,00
		64-14M-85	14M8564	10WF	F70	64	285,21	282,41	296	150	240	102	102	32	30,50
		72-14M-85	14M8572	10A		72	320,86	318,06	—	150	278	102	102	32	28,80
		80-14M-85	14M8580	10A		80	356,51	353,71	—	150	314	102	102	32	30,10
		90-14M-85	14M8590	10A		90	401,07	398,28	—	150	358	102	102	32	33,00
		112-14M-85	14M8511	10A		112	499,11	496,32	—	150	456	102	102	32	41,80
		144-14M-85	14M8514	10A		144	641,71	638,92	—	150	600	102	102	32	52,40
		168-14M-85	14M8516	10A		168	748,66	745,87	—	150	706	102	102	32	60,30
		192-14M-85	14M8519	10A		192	855,62	852,82	—	165	813	102	102	32	70,20
		216-14M-85	14M8521	10A		216	962,57	959,76	—	160	920	102	102	32	81,00

HTD® 14M-115

CARATTERISTICHE FEATURES MERKMALE CARACTERISTIQUES CARACTERÍSTICAS		CODICE CODE SYMBOL FABRIKNUMER CODE SYMBOLE NEMERO DE FABRICA	NOSTRO CODICE OUR CODE UNSER KODE NOTRE CODE NUESTRO CODIGO	TIPO TYPE TYP TYPE TIPO	TIPO FLANGIA FLANGES TYPE BORDSCHEIBEN TYP TYPE FLASQUES TIPO TAPETAS	N. DENTI N. OF TEETH ZAHNEZAHL N. BRE DE DENTS CANTIDAD DE DIENTES	Dp	De	Df	Dm	Di	F	L	d	PESO WEIGHT GEWICHT POIDS PESO Kg		
ACCIAIO STEEL STAHL ACIER ACERO	CON FLANGIA WITH FLANGES MIT FLANGES AVEC FLASQUES CON TAPETAS	28-14M-115	14M1128	6F	F40	28	124,78	122,12	128	100	—	133	148	32	9,20		
		29-14M-115	14M1129	6F	F43	29	129,23	126,57	138	100	—	133	148	32	10,20		
		30-14M-115	14M1130	6F	F43	30	133,69	130,99	138	100	—	133	148	32	11,20		
		32-14M-115	14M1132	6F	F49	32	142,60	139,88	154	100	—	133	148	32	13,20		
		34-14M-115	14M1134	6F	F51	34	151,52	148,79	160	100	—	133	148	32	14,80		
		36-14M-115	14M1136	6F	F52	36	160,43	157,68	168	100	—	133	148	32	16,60		
		38-14M-115	14M1138	6F	F55	38	169,34	166,60	184	120	—	133	148	32	19,20		
		40-14M-115	14M1140	6F	F56	40	178,25	175,49	188	135	—	133	148	32	20,56		
		44-14M-115	14M1144	6F	F61	44	196,08	193,28	212	140	—	133	148	32	21,93		
		48-14M-115	14M1148	6F	F62	48	213,90	211,11	226	150	—	133	148	32	25,00		
		56-14M-115	14M1156	6F	F66	56	249,55	246,76	256	150	—	133	148	32	27,50		
		64-14M-115	14M1164	10WF	F70	64	285,21	282,41	296	150	240	133	133	32	30,10		
		GHISA CAST IRON GRAUGUSS FONTE HIERRO FUNDIDO	SENZA FLANGIA WITHOUT FLANGES OHNE FLANSCHEN SANS FLASQUES SIN TAPETAS	72-14M-115	14M1172	10A		72	320,86	318,06	—	150	278	133	133	32	32,83
				80-14M-115	14M1180	10A		80	356,51	353,71	—	150	314	133	133	32	35,55
90-14M-115	14M1190			10A		90	401,07	398,28	—	150	358	133	133	32	41,00		
112-14M-115	14M1111			10A		112	499,11	496,32	—	150	456	133	133	32	54,40		
144-14M-115	14M1114			10A		144	641,71	638,92	—	165	600	133	133	32	67,80		
168-14M-115	14M1116			10A		168	748,66	745,87	—	165	706	133	133	32	75,80		
192-14M-115	14M1119			10A		192	855,62	852,82	—	165	813	133	133	32	88,30		
216-14M-115	14M1121			10A		216	962,57	959,76	—	165	920	133	133	32	98,00		

HTD® 14M-170

CARATTERISTICHE FEATURES MERKMALE CARACTERISTIQUES CARACTERÍSTICAS		CODICE CODE SYMBOL FABRIKNUMER CODE SYMBOLE NEMERO DE FABRICA	NOSTRO CODICE OUR CODE UNSER KODE NOTRE CODE NUESTRO CODIGO	TIPO TYPE TYP TYPE TIPO	TIPO FLANGIA FLANGES TYPE BORDSCHEIBEN TYP TYPE FLASQUES TIPO TAPETAS	N. DENTI N. OF TEETH ZAHNEZAHL N. BRE DE DENTS CANTIDAD DE DIENTES	Dp	De	Df	Dm	Di	F	L	d	PESO WEIGHT GEWICHT POIDS PESO Kg		
ACCIAIO STEEL STAHL ACIER ACERO	CON FLANGIA WITH FLANGES MIT FLANGES AVEC FLASQUES CON TAPETAS	28-14M-170	14M1728	6F	F40	28	124,78	122,12	128	100	—	133	148	32	9,20		
		29-14M-170	14M1729	6F	F43	29	129,23	126,57	138	100	—	133	148	32	10,20		
		30-14M-170	14M1730	6F	F43	30	133,69	130,99	138	100	—	133	148	32	11,20		
		32-14M-170	14M1732	6F	F49	32	142,60	139,88	154	100	—	133	148	32	13,20		
		34-14M-170	14M1734	6F	F51	34	151,52	148,79	160	100	—	133	148	32	14,80		
		36-14M-170	14M1736	6F	F52	36	160,43	157,68	168	100	—	133	148	32	16,60		
		38-14M-170	14M1738	6F	F55	38	169,34	166,60	184	120	—	133	148	32	19,20		
		40-14M-170	14M1740	6F	F56	40	178,25	175,49	188	135	—	133	148	32	20,56		
		44-14M-170	14M1744	6F	F61	44	196,08	193,28	212	140	—	133	148	32	21,93		
		48-14M-170	14M1748	6F	F62	48	213,90	211,11	226	150	—	133	148	32	25,00		
		56-14M-170	14M1756	6F	F66	56	249,55	246,76	256	150	—	133	148	32	27,50		
		64-14M-170	14M1764	10WF	F70	64	285,21	282,41	296	150	240	133	133	32	30,10		
		GHISA CAST IRON GRAUGUSS FONTE HIERRO FUNDIDO	SENZA FLANGIA WITHOUT FLANGES OHNE FLANSCHEN SANS FLASQUES SIN TAPETAS	72-14M-170	14M1772	10A		72	320,86	318,06	—	150	278	133	133	32	32,83
				80-14M-170	14M1780	10A		80	356,51	353,71	—	150	314	133	133	32	35,55
90-14M-170	14M1790			10A		90	401,07	398,28	—	150	358	133	133	32	41,00		
112-14M-170	14M1711			10A		112	499,11	496,32	—	150	456	133	133	32	54,40		
144-14M-170	14M1714			10A		144	641,71	638,92	—	165	600	133	133	32	67,80		
168-14M-170	14M1716			10A		168	748,66	745,87	—	165	706	133	133	32	75,80		
192-14M-170	14M1719			10A		192	855,62	852,82	—	165	813	133	133	32	88,30		
216-14M-170	14M1721			10A		216	962,57	959,76	—	165	920	133	133	32	98,00		

HTD® 20M-115

CARATTERISTICHE FEATURES MERKMALE CARACTERISTIQUES CARACTERÍSTICAS		CODICE CODE SYMBOL FABRIKNUMER CODE SYMBOLE NEMERO DE FABRICA	NOSTRO CODICE OUR CODE UNSER KODE NOTRE CODE NUESTRO CODIGO	TIPO TYPE TYP TYPE TIPO	TIPO FLANGIA FLANGES TYPE BORDSCHEIBEN TYP TYPE FLASQUES TIPO TAPETAS	N.DENTI N. OF TEETH ZAHNEZAHL N. BRE DE DENTS CANTIDAD DE DIENTES	Dp	De	Df	Dm	Di	F	L	e	d	PESO WEIGHT GEWICHT POIDS PESO Kg
GHISA CAST IRON GRAUGUSS FONTE HIERRO FUNDIDO	CON FLANGIA WITH FLANGES MIT FLANSCHEN AVEC FLASQUES CON TAPETAS	34-20M-115	20M1134	6F	F64	34	216.45	212.13	240	165	-	136,5	168,5	-	32	39
		36-20M-115	20M1136	6F	F65	36	229.18	224.87	250	178	-	136,5	168,5	-	32	44
		38-20M-115	20M1138	6F	F67	38	241.92	237.60	265	181	-	136,5	168,5	-	32	49
		40-20M-115	20M1140	6F	F68	40	254.65	250.33	275	203	-	136,5	168,5	-	32	
		44-20M-115	20M1144	6F	F71	44	280.11	275.79	300	210	-	136,5	168,5	-	32	
		48-20M-115	20M1148	6F	F72	48	305.58	301.26	325	228	-	136,5	168,5	-	32	
		52-20M-115	20M1152	6F	F73	52	331.04	326.72	350	228	-	136,5	168,5	-	32	
		56-20M-115	20M1156	6F	F74	56	356.51	352.19	375	228	-	136,5	168,5	-	32	
		60-20M-115	20M1160	6WF	F75	60	381.97	377.65	405	228	318	136,5	168,5	-	38	
		64-20M-115	20M1164	6WF	F76	64	407.44	403.12	430	228	343	136,5	168,5	-	38	
	68-20M-115	20M1168	6WF	F77	68	432.90	428.58	455	228	366	136,5	168,5	-	38		
	72-20M-115	20M1172	6AF	F78	72	458.37	454.05	480	228	435	136,5	168,5	-	38		
	80-20M-115	20M1180	6AF	F79	80	509.30	504.98	530	280	445	136,5	168,5	-	38		
	90-20M-115	20M1190	6AF	F80	90	572.96	568.64	595	280	508	136,5	168,5	-	38		
	SENZA FLANGIA WITHOUT FLANGES OHNE FLANSCHEN SANS FLASQUES SIN TAPETAS	112-20M-115	20M1111	6A		112	713,01	708,70	-	280	648	136,5	168,5	-	38	
		144-20M-115	20M1114	6A		144	916,73	912,41	-	300	852	136,5	168,5	-	44	
		168-20M-115	20M1116	6A		168	1069,52	1065,21	-	300	1005	136,5	168,5	-	44	
		192-20M-115	20M1119	6A		192	1222,31	1218,00	-	300	1158	136,5	168,5	-	48	
		216-20M-115	20M1121	6A		216	1375,10	1370,78	-	300	1300	136,5	168,5	-	48	

HTD® 20M-170

CARATTERISTICHE FEATURES MERKMALE CARACTERISTIQUES CARACTERÍSTICAS		CODICE CODE SYMBOL FABRIKNUMER CODE SYMBOLE NEMERO DE FABRICA	NOSTRO CODICE OUR CODE UNSER KODE NOTRE CODE NUESTRO CODIGO	TIPO TYPE TYP TYPE TIPO	TIPO FLANGIA FLANGES TYPE BORDSCHEIBEN TYP TYPE FLASQUES TIPO TAPETAS	N.DENTI N. OF TEETH ZAHNEZAHL N. BRE DE DENTS CANTIDAD DE DIENTES	Dp	De	Df	Dm	Di	F	L	e	d	PESO WEIGHT GEWICHT POIDS PESO Kg
GHISA CAST IRON GRAUGUSS FONTE HIERRO FUNDIDO	CON FLANGIA WITH FLANGES MIT FLANSCHEN AVEC FLASQUES CON TAPETAS	34-20M-170	20M1734	6F	F64	34	216.45	212.13	240	165	-	190,5	222,5	-	32	44,8
		36-20M-170	20M1736	6F	F65	36	229.18	224.87	250	178	-	190,5	222,5	-	32	50,5
		38-20M-170	20M1738	6F	F67	38	241.92	237.60	265	181	-	190,5	222,5	-	32	55,0
		40-20M-170	20M1740	6F	F68	40	254.65	250.33	275	203	-	190,5	222,5	-	32	
		44-20M-170	20M1744	6F	F71	44	280.11	275.79	300	210	-	190,5	222,5	-	32	
		48-20M-170	20M1748	6F	F72	48	305.58	301.26	325	240	-	190,5	222,5	-	32	
		52-20M-170	20M1752	6F	F73	52	331.04	326.72	350	280	-	190,5	222,5	-	32	
		56-20M-170	20M1756	6F	F74	56	356.51	352.19	375	280	-	190,5	222,5	-	32	
		60-20M-170	20M1760	6F	F75	60	381.97	377.65	405	280	-	190,5	222,5	-	38	
		64-20M-170	20M1764	6F	F76	64	407.44	403.12	430	280	-	190,5	222,5	-	38	
	68-20M-170	20M1768	6F	F77	68	432.90	428.58	455	280	-	190,5	222,5	-	38		
	72-20M-170	20M1772	10AF	F78	72	458.37	454.05	480	280	394	190,5	190,5	-	38		
	80-20M-170	20M1780	10AF	F79	80	509.30	504.98	530	280	445	190,5	190,5	-	38		
	90-20M-170	20M1790	10AF	F80	90	572.96	568.64	595	280	508	190,5	190,5	-	38		
	SENZA FLANGIA WITHOUT FLANGES OHNE FLANSCHEN SANS FLASQUES SIN TAPETAS	112-20M-170	20M1711	10A		112	713,01	708,70	-	300	648	190,5	190,5	-	38	
		144-20M-170	20M1714	10A		144	916,73	912,41	-	300	852	190,5	190,5	-	44	
		168-20M-170	20M1716	10A		168	1069,52	1065,21	-	350	1005	190,5	190,5	-	44	
		192-20M-170	20M1719	10A		192	1222,31	1218,00	-	350	1158	190,5	190,5	-	48	
		216-20M-170	20M1721	10A		216	1375,10	1370,78	-	350	1300	190,5	190,5	-	48	

HTD® 20M-230

CARATTERISTICHE FEATURES MERKMALE CARACTERISTIQUES CARACTERÍSTICAS		CODICE CODE SYMBOL FABRIKNUMER CODE SYMBOLE NEMERO DE FABRICA	NOSTRO CODICE OUR CODE UNSER KODE NOTRE CODE NUESTRO CODIGO	TIPO TYPE TYP TYPE TIPO	TIPO FLANGIA FLANGES TYPE BORDSCHEIBEN TYP TYPE FLASQUES TIPO TAPETAS	N.DENTI N. OF TEETH ZAHNEZAHL N. BRE DE DENTS CANTIDAD DE DIENTES	Dp	De	Df	Dm	Di	F	L	e	d	PESO WEIGHT GEWICHT POIDS PESO Kg
GHISA CAST IRON GRAUGUSS FONTE HIERRO FUNDIDO	CON FLANGIA WITH FLANGES MIT FLANGES AVEC FLASQUES CON TAPETAS	38-20M-230	20M2338	6F	F67	38	241.92	237.60	265	181	-	250,8	282,8	-	38	67,5
		40-20M-230	20M2340	6F	F68	40	254.65	250.33	275	203	-	250,8	282,8	-	38	
		44-20M-230	20M2344	6F	F71	44	280.11	275.79	300	210	-	250,8	282,8	-	38	
		48-20M-230	20M2348	6F	F72	48	305.58	301.26	325	228	-	250,8	282,8	-	38	
		52-20M-230	20M2352	6F	F73	52	331.04	326.72	350	280	-	250,8	282,8	-	38	
		56-20M-230	20M2356	6F	F74	56	356.51	352.19	375	280	-	250,8	282,8	-	32	
		60-20M-230	20M2360	6F	F75	60	381.97	377.65	405	280	-	250,8	282,8	-	38	
		64-20M-230	20M2364	6F	F76	64	407.44	403.12	430	300	-	250,8	282,8	-	38	
		68-20M-230	20M2368	6F	F77	68	432.90	428.58	455	300	-	250,8	282,8	-	38	
		72-20M-230	20M2372	6F	F78	72	458.37	454.05	480	300	-	250,8	282,8	-	38	
	80-20M-230	20M2380	10WF	F79	80	509,30	504,98	530	300	445	250,8	250,8	-	38		
	90-20M-230	20M2390	10AF	F80	90	572,96	568,64	595	300	508	250,8	250,8	-	38		
	SENZA FLANGIA WITHOUT FLANGES OHNE FLANSCHEN SANS FLASQUES SIN TAPETAS	112-20M-230	20M2311		10A		112	713,01	708,70	-	300	648	250,8	250,8	-	38
		144-20M-230	20M2314		10A		144	916,73	912,41	-	350	852	250,8	250,8	-	44
		168-20M-230	20M2316		10A		168	1069,52	1065,21	-	350	1005	250,8	250,8	-	44
		192-20M-230	20M2319		10A		192	1222,31	1218,00	-	400	1158	250,8	250,8	-	48
		216-20M-230	20M2321		10A		216	1375,10	1370,78	-	400	1300	250,8	250,8	-	48

HTD® 20M-290

CARATTERISTICHE FEATURES MERKMALE CARACTERISTIQUES CARACTERÍSTICAS		CODICE CODE SYMBOL FABRIKNUMER CODE SYMBOLE NEMERO DE FABRICA	NOSTRO CODICE OUR CODE UNSER KODE NOTRE CODE NUESTRO CODIGO	TIPO TYPE TYP TYPE TIPO	TIPO FLANGIA FLANGES TYPE BORDSCHEIBEN TYP TYPE FLASQUES TIPO TAPETAS	N.DENTI N. OF TEETH ZAHNEZAHL N. BRE DE DENTS CANTIDAD DE DIENTES	Dp	De	Df	Dm	Di	F	L	e	d	PESO WEIGHT GEWICHT POIDS PESO Kg
GHISA CAST IRON GRAUGUSS FONTE HIERRO FUNDIDO	CON FLANGIA WITH FLANGES MIT FLANGES AVEC FLASQUES CON TAPETAS	52-20M-170	20M2952	6F	F73	52	331.04	326.72	350	280	-	311,2	343	-	38	
		56-20M-170	20M2956	6F	F74	56	356.51	352.19	375	280	-	311,2	343	-	38	
		60-20M-170	20M2960	6F	F75	60	381.97	377.65	405	300	-	311,2	343	-	38	
		64-20M-170	20M2964	6F	F76	64	407.44	403.12	430	300	-	311,2	343	-	38	
		68-20M-170	20M2968	6F	F77	68	432.90	428.58	455	300	-	311,2	343	-	38	
		72-20M-170	20M2972	6F	F78	72	458.37	454.05	480	300	-	311,2	343	-	44	
		80-20M-170	20M2980	6F	F79	80	509,30	504,98	530	300	-	311,2	343	-	44	
		90-20M-170	20M2990	10WF	F80	90	572,96	568,64	595	300	508	311,2	311,2	-	44	
	SENZA FLANGIA WITHOUT FLANGES OHNE FLANSCHEN SANS FLASQUES SIN TAPETAS	112-20M-170	20M2911		10A		112	713,01	708,70	-	350	648	311,2	311,2	-	48
		144-20M-170	20M2914		10A		144	916,73	912,41	-	350	852	311,2	311,2	-	48
		168-20M-170	20M2916		10A		168	1069,52	1065,21	-	400	1005	311,2	311,2	-	48
		192-20M-170	20M2919		10A		192	1222,31	1218,00	-	400	1158	311,2	311,2	-	48
		216-20M-170	20M2921		10A		216	1375,10	1370,78	-	400	1300	311,2	311,2	-	48

HTD® 20M-340

CARATTERISTICHE FEATURES MERKMALE CARACTERISTIQUES CARACTERÍSTICAS		CODICE CODE SYMBOL FABRIKNUMMER CODE SYMBOLE NEMERO DE FABRICA	NOSTRO CODICE OUR CODE UNSER KODE NOTRE CODE NUESTRO CODIGO	TIPO TYPE TYP TYPE TIPO	TIPO FLANGIA FLANGES TYPE BORDSCHEIBEN TYP TYPE FLASQUES TIPO TAPETAS	N.DENTI N. OF TEETH ZAHNEZAHL N. BRE DE DENTS CANTIDAD DE DIENTES	Dp	De	Df	Dm	Di	F	L	e	d	PESO WEIGHT GEWICHT POIDS PESO Kg	
GHISA CAST IRON GRAUGUSS FONTE HIERRO FUNDIDO	CON FLANGIA WITH FLANGES MIT FLANGES AVEC FLASQUES CON TAPETAS	52-20M-340	20M3452	6F	F73	52	331.04	326.72	350	280	-	362	394	-	38		
		56-20M-340	20M3456	6F	F74	56	356.51	352.19	375	280	-	362	394	-	38		
		60-20M-340	20M3460	6F	F75	60	381.97	377.65	405	300	-	362	394	-	38		
		64-20M-340	20M3464	6F	F76	64	407.44	403.12	430	300	-	362	394	-	44		
		68-20M-340	20M3468	6F	F77	68	432.90	428.58	455	300	-	362	394	-	44		
		72-20M-340	20M3472	6F	F78	72	458.37	454.05	480	300	-	362	394	-	44		
		80-20M-340	20M3480	6F	F79	80	509,30	504,98	530	300	-	362	394	-	44		
		90-20M-340	20M3490	10WF	F80	90	572,96	568,64	595	300	508	362	394	-	48		
		112-20M-340	20M3411	10A		112	713,01	708,70	-	350	648	362	362	-	48		
	144-20M-340	20M3414	10A		144	916,73	912,41	-	350	852	362	362	-	48			
	168-20M-340	20M3416	10A		168	1069,52	1065,21	-	400	1005	362	362	-	48			
	192-20M-340	20M3419	10A		192	1222,31	1218,00	-	400	1158	362	362	-	48			
	216-20M-340	20M3421	10A		216	1375,10	1370,78	-	400	1300	362	362	-	48			
	SENZA FLANGIA WITHOUT FLANGES OHNE FLANSCHEN SANS FLASQUES SIN TAPETAS																

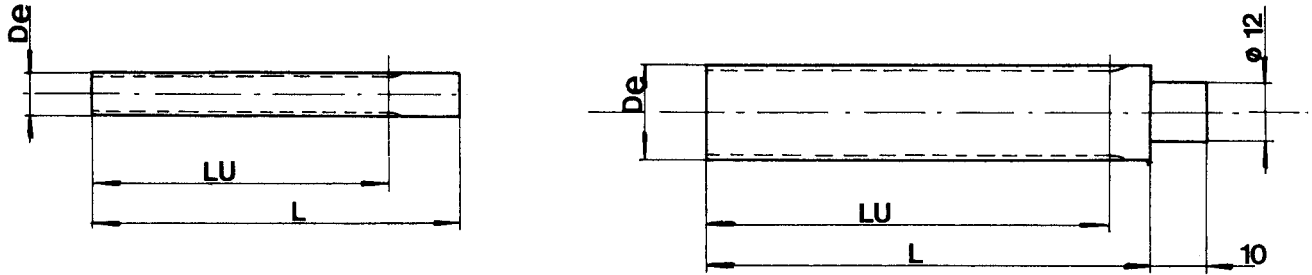

Materiale: alluminio UNI 3571 TA 16 adatto al trattamento anodico
 Material: aluminium UNI 3571 TA 16 suitable for anodic treatment
 Material: aluminium UNI 3571 TA 16 geeignet für anodischen oxydation
 Material:aluminium UNI 3571 TA 16 apte au traitement anodique
 Material: aluminio UNI 3571 TA 16 apto para la oxidacion anodica

HTD® 3M

CODICE CODE SYMBOL FABRIKNUMER CODE SYMBOLE NEMERO DE FABRICA	NOSTRO CODICE OUR CODE UNSER KODE NOTRE CODE NUESTRO CODIGO	N. DENTI N. OF TEETH ZAHNEZAHL N. BRE DE DENTS CANTIDAD DE DIENTES	Dp	De	Lu	L
9 - 3M	B03M009	9	8,59	7,83	75	100
10 - 3M	B03M010	10	9,55	8,79	75	100
11 - 3M	B03M011	11	10,50	9,74	75	100
12 - 3M	B03M012	12	11,46	10,70	100	125
13 - 3M	B03M013	13	12,41	11,65	100	125
14 - 3M	B03M014	14	13,37	12,61	100	125
15 - 3M	B03M015	15	14,32	13,56	100	125
16 - 3M	B03M016	16	15,28	14,52	125	155
17 - 3M	B03M017	17	16,23	15,47	125	155
18 - 3M	B03M018	18	17,19	16,43	125	155
19 - 3M	B03M019	19	18,14	17,38	125	155
20 - 3M	B03M020	20	19,10	18,34	150	165
21 - 3M	B03M021	21	20,05	19,25	150	165
22 - 3M	B03M022	22	21,01	20,25	150	165
23 - 3M	B03M023	23	21,96	21,20	150	165
24 - 3M	B03M024	24	22,92	22,16	150	165
25 - 3M	B03M025	25	23,87	23,11	150	165
26 - 3M	B03M026	26	24,83	24,07	150	165
27 - 3M	B03M027	27	25,78	25,02	150	165
28 - 3M	B03M028	28	26,74	25,98	150	165
29 - 3M	B03M029	29	27,69	26,93	150	165
30 - 3M	B03M030	30	28,65	27,89	175	183
31 - 3M	B03M031	31	29,60	28,84	175	183
32 - 3M	B03M032	32	30,56	29,80	175	183

CODICE CODE SYMBOL FABRIKNUMER CODE SYMBOLE NEMERO DE FABRICA	NOSTRO CODICE OUR CODE UNSER KODE NOTRE CODE NUESTRO CODIGO	N. DENTI N. OF TEETH ZAHNEZAHL N. BRE DE DENTS CANTIDAD DE DIENTES	Dp	De	Lu	L
33 - 3M	B03M033	33	31,54	30,75	175	183
34 - 3M	B03M034	34	32,47	31,71	175	183
35 - 3M	B03M035	35	33,42	32,66	175	183
36 - 3M	B03M036	36	34,38	33,62	200	200
37 - 3M	B03M037	37	35,33	34,57	200	200
38 - 3M	B03M038	38	36,29	35,53	200	200
39 - 3M	B03M039	39	37,24	36,48	200	200
40 - 3M	B03M040	40	38,20	37,44	200	200
42 - 3M	B03M042	42	40,11	39,34	200	200
44 - 3M	B03M044	44	42,02	41,26	200	200
45 - 3M	B03M045	45	42,97	42,21	200	200
48 - 3M	B03M048	48	45,84	45,08	200	200
50 - 3M	B03M050	50	47,75	46,99	200	200
52 - 3M	B03M052	52	49,66	48,90	200	200
54 - 3M	B03M054	54	51,57	50,81	200	200
56 - 3M	B03M056	56	53,48	52,72	200	200
60 - 3M	B03M060	60	57,30	56,54	200	200
62 - 3M	B03M062	62	59,21	58,45	200	200
64 - 3M	B03M064	64	61,12	60,36	200	200
66 - 3M	B03M066	66	63,03	62,27	200	200
68 - 3M	B03M068	68	64,94	64,18	200	200
70 - 3M	B03M070	70	66,85	66,09	200	200
72 - 3M	B03M072	72	68,75	67,99	200	200

HTD® 5M

CODICE CODE SYMBOL FABRIKNUMER CODE SYMBOLE NEMERO DE FABRICA	NOSTRO CODICE OUR CODE UNSER KODE NOTRE CODE NUESTRO CODIGO	N. DENTI N. OF TEETH ZAHNEZAHL N. BRE DE DENTS CANTIDAD DE DIENTES	Dp	De	Lu	L
12 - 5M	B05M012	12	19,10	17,96	150	165
13 - 5M	B05M013	13	20,69	19,55	150	165
14 - 5M	B05M014	14	22,28	21,14	175	183
15 - 5M	B05M015	15	23,87	22,73	175	183
16 - 5M	B05M016	16	25,46	24,32	175	183
17 - 5M	B05M017	17	27,06	25,92	175	183
18 - 5M	B05M018	18	28,65	27,51	200	200
19 - 5M	B05M019	19	30,24	29,10	200	200
20 - 5M	B05M020	20	31,83	30,69	200	200
21 - 5M	B05M021	21	33,42	32,28	200	200
22 - 5M	B05M022	22	35,01	33,87	200	200
23 - 5M	B05M023	23	36,61	35,47	200	200
24 - 5M	B05M024	24	38,20	37,06	200	200
25 - 5M	B05M025	25	39,79	38,65	200	200
26 - 5M	B05M026	26	41,38	40,24	200	200
27 - 5M	B05M027	27	42,97	41,83	200	200
28 - 5M	B05M028	28	44,56	43,42	200	200
29 - 5M	B05M029	29	46,15	45,01	200	200
30 - 5M	B05M030	30	47,75	46,60	200	200

CODICE CODE SYMBOL FABRIKNUMER CODE SYMBOLE NEMERO DE FABRICA	NOSTRO CODICE OUR CODE UNSER KODE NOTRE CODE NUESTRO CODIGO	N. DENTI N. OF TEETH ZAHNEZAHL N. BRE DE DENTS CANTIDAD DE DIENTES	Dp	De	Lu	L
31 - 5M	B05M031	31	49,34	48,20	200	200
32 - 5M	B05M032	32	50,93	49,79	200	200
33 - 5M	B05M033	33	52,52	51,38	200	200
34 - 5M	B05M034	34	54,11	52,97	200	200
35 - 5M	B05M035	35	55,70	54,56	200	200
36 - 5M	B05M036	36	57,30	56,16	200	200
38 - 5M	B05M038	38	60,48	59,34	200	200
40 - 5M	B05M040	40	63,66	62,52	200	200
42 - 5M	B05M042	42	66,85	65,71	200	200
44 - 5M	B05M044	44	70,03	68,89	200	200
45 - 5M	B05M045	45	71,62	70,48	200	200
46 - 5M	B05M046	46	73,21	72,07	200	200
48 - 5M	B05M048	48	76,39	75,25	200	200
50 - 5M	B05M050	50	79,58	78,43	200	200
54 - 5M	B05M054	54	85,94	84,80	200	200
60 - 5M	B05M060	60	95,49	94,35	200	200
62 - 5M	B05M062	62	98,68	97,54	200	200
72 - 5M	B05M072	72	114,59	113,45	200	200



N. DENTI N. OF TEETH ZÄHNEZAHL NOMBRE DE DENTS CANTIDAD DE DIENTES	FLANGIA - FLANGES - BORDSCHEIBEN - FLASQUES - TAPETAS					TIPO FLANGIA FLANGES TYPE BORDSCHEIBEN TYP TYPE FLASQUES TIPO TAPETAS			
	d = 0,5 mm	d = 1 mm	d = 1,5 mm	d = 2,5 mm	d = 4 mm				
	HTD® 3M	HTD® 5M	HTD® 8M	HTD® 14M	HTD® 20M				
10	F 01	-	-	-	-	F 01	13	10	6
11	-	-	-	-	-	F 02	15	12	8
12	F 02	F 07	-	-	-	F 03	16	13	9,5
13	-	-	-	-	-	F 04	17,5	14,5	11,6
14	F 03	F 08	-	-	-	F 05	18	15	11,5
15	F 04	F 09	-	-	-	F 06	20	16,5	12,2
16	F 05	F 09	-	-	-	F 07	23	18	12,5
17	-	-	-	-	-	F 08	25	21,5	15
18	F 06	F 10	-	-	-	F 09	28	24	17,8
19	-	-	-	-	-	F 10	32	27,5	23
20	F 07	F 12	-	-	-	F 11	35	30,5	23
21	F 08	F 14	-	-	-	F 12	36	31	25
22	F 08	F 14	F 22	-	-	F 13	37	33	25
23	-	-	-	-	-	F 14	38	34	26,5
24	F 08	F 15	F 25	-	-	F 15	42	38	30,5
25	-	-	-	-	-	F 16	43	39	31
26	F 09	F 17	F 26	-	-	F 17	44	40,5	32,5
27	-	-	-	-	-	F 18	48	43,5	37
28	F 10	F 18	F 27	F 40	-	F 19	51	47	40
29	-	-	-	F 43	-	F 20	54	50,5	43
30	F 10	F 19	F 29	F 43	-	F 21	57	52	46
31	-	-	-	-	-	F 22	60	57	47
32	F 12	F 20	F 30	F 49	-	F 23	61	56,5	49
33	-	-	-	-	-	F 24	64	57	47
34	-	F 21	F 31	F 51	F 64	F 25	66	63	52
35	-	-	-	-	-	F 26	70	66,5	53
36	F 14	F 22	F 33	F 52	F 65	F 27	75	68,5	60
37	-	-	-	-	-	F 28	79	72,5	60
38	-	F 25	F 34	F 55	F 67	F 29	83	78	68
39	-	-	-	-	-	F 30	87	82,5	72
40	F 15	F 26	F 35	F 56	F 68	F 31	91	85,5	76
41	-	-	-	-	-	F 32	93	89	80
42	-	-	-	-	-	F 33	97	93,8	83
43	-	-	-	-	-	F 34	102	97	82,5
44	F 18	F 27	F 38	F 61	F 71	F 35	106	101	90
45	-	-	-	-	-	F 36	112	105,5	91
46	-	-	-	-	-	F 37	115	109	94
47	-	-	-	-	-	F 38	120	112,5	99,5
48	-	F 29	F 40	F 62	F 72	F 39	123	117,5	107
49	-	-	-	-	-	F 40	128	124	107
50	-	-	-	-	-	F 41	131	125,5	115
51	-	-	-	-	-	F 42	135	128,5	115
52	-	-	-	-	F 73	F 43	138	132	121
53	-	-	-	-	-	F 44	140	125	107
54	-	-	-	-	-	F 45	142	137	120
55	-	-	-	-	-	F 46	146	133	107
56	-	F 32	F 48	F 66	F 74	F 47	148	143	132
57	-	-	-	-	-	F 48	150	145	130
58	-	-	-	-	-	F 49	154	142	122
59	-	-	-	-	-	F 50	158	153	138,5
60	-	-	-	-	-	F 51	160	148	120
61	-	-	-	-	-	F 52	168	161	148
62	-	-	-	-	-	F 53	175	170	157
63	-	-	-	-	-	F 54	180	174	154
64	-	F 35	F 52	F 70	F 76	F 55	184	168	135
65	-	-	-	-	-	F 56	188	176	150
66	-	-	-	-	-	F 57	192	187	173
67	-	-	-	-	-	F 58	198	180	150
68	-	-	-	-	F 77	F 59	200	193	180
69	-	-	-	-	-	F 60	205	189	160
70	-	-	-	-	-	F 61	212	200	162
71	-	-	-	-	-	F 62	226	214	190
72	-	-	F 57	-	F 78	F 63	230	222	200
80	-	-	-	-	F 79	F 64	240	224	192
90	-	-	-	-	F 80	F 65	250	228	200
						F 66	256	240	220
						F 67	265	240	213
						F 68	275	253	225
						F 69	286	277	242
						F 70	296	287	260
						F 71	300	280	252
						F 72	325	305	278
						F 73	350	330	302
						F 74	375	355	328
						F 75	405	380	354
						F 76	430	406	380
						F 77	455	432	405
						F 78	480	457	430
						F 79	530	508	481
						F 80	595	572	544

Pulegge dentate per cinghie passo metrico
Timing belt pulleys metric pitch
Zahnriemenscheiben metrische teilung
Poulies dentées pour courroies pas métrique
Poleas dentadas para correas con
paso en mm

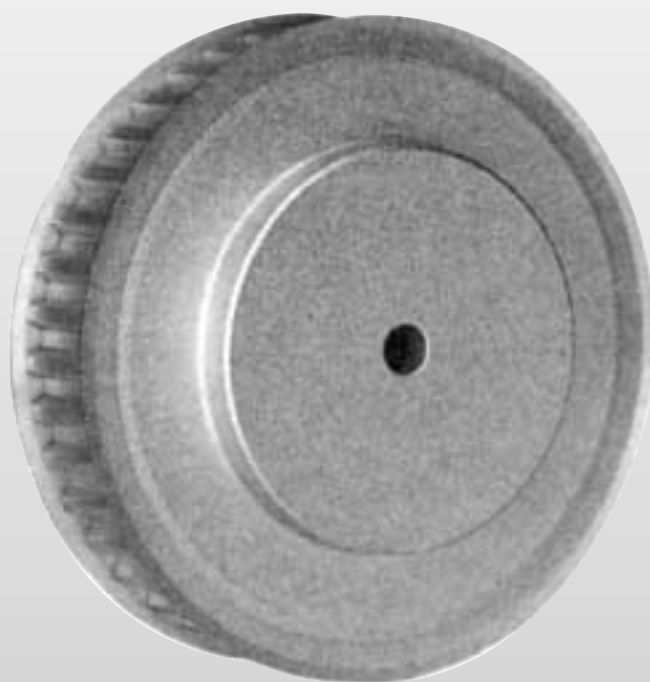

Istruzioni per l'identificazione e la classificazione delle pulegge a passo metrico
Instructions for the identification and classification of timing belt pulleys metric pitch
Leitfaden zur suche und Klassifizierung der Zahnriemenscheiben metrische Teilung
Instructions pour la recherche et la classification des poulies dentées pas métrique
Guia a la busca y clasificación de las poleas dentadas en paso en mm

Esempio:
ALTEZZA 40 T 10/32-2
 40 = Larghezza totale della puleggia 40 mm (L)
 T 10 = Passo 10 mm
 30 = N. denti
 2 = N. della flangia

Example:
PULLEY 40 T 10/32-2
 40 = Total width of pulley 40 mm (L)
 T 10 = Pitch 10 mm
 30 = No. of teeth
 2 = No. of flanges

Beispiel:
SCHIBE 40 T 10/32-2
 40 = Gesamtbreite der Scheibe 40 mm (L)
 T 10 = Teilung 10 mm
 30 = Zähnezahl
 2 = Anzahl der Bordscheiben

Exemple:
POULIE 40 T 10/32-2
 40 = Largeur totale de la poulie 40 mm (L)
 T 10 = Pas 10 mm
 30 = N. de dents
 2 = N. de flasques

Ejemplo:
POLEA 40 T 10/32-2
 40 = Ancho total de la polea 40 mm (L)
 T 10 = Paso 10 mm
 30 = Cantidad de dientes
 2 = Cantidad de tapetas

Materiale:
alluminio 6082 T6
UNI 9006/4 adatto al trattamento anodico

Material:
aluminium 6082 T6
UNI 9006/4 suitable for anodic treatment

Material:
aluminium 6082 T6
UNI 9006/4 geeignet für anodischen oxydation

Material:
aluminium 6082 T6
UNI 9006/4 apte au traitement anodique

Material:
aluminio 6082 T6
UNI 9006/4 apto para la oxidación anodica

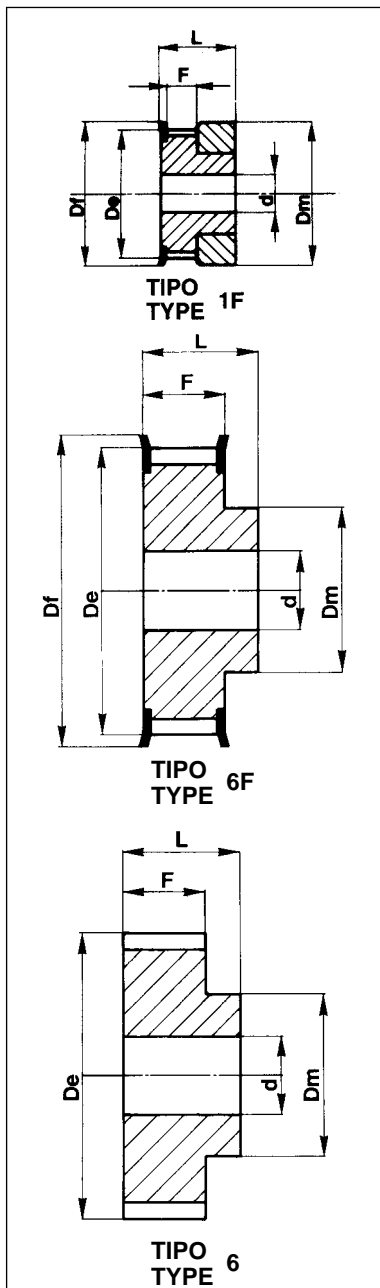

Pulegge dentate per cinghie passo metrico
Timing belt pulleys metric pitch
Zahnriemenscheiben metrische teilung
Poulies dentées pour courroies pas métrique
Poleas dentadas para correas con paso en mm

T 2,5

(PASSO 2,5 mm) PER CINGHIA LARGHEZZA 6 mm
 (PITCH 2,5 mm) FOR BELT WIDTH 6 mm
 (TEILUNG 2,5 mm) FUER RIEMENBREITE 6 mm
 (PAS 2,5 mm) POUR COURROIES LARGEUR 6 mm
 (PASO 2,5 mm) PARA CORREAS ANCHO 6 mm

CODICE CODE SYMBOL FABRIKNUMMER CODE SYMBOLE NUMERO DE FABRICA	NOSTRO CODICE OUR CODE UNSER KODE NOTRE CODE NUESTRO CODIGO	TIPO TYPE TYP TIPO TIPO	TIPO FLANGIA FLANGES TYPE BORDSCHEIBEN TYP TIPO FLASQUES TIPO TAPETAS	N.DENTI N. OF TEETH ZAHNEZAHL N. BRE DE DENTS CANTIDAD DE DIENTES	Dp	De	Df	Dm	F	L	d	PESO WEIGHT POIDS PESO Kg
16T2,5/12-2	16T2012	1F	F01	12	9,60	9,00	13,0	13	9	16	4	0,004
16T2,5/14-2	16T2014	1F	F02	14	11,20	10,60	15,0	15	9	16	4	0,006
16T2,5/15-2	16T2015	1F	F02	15	12,00	11,40	15,0	15	9	16	4	0,006
16T2,5/16-2	16T2016	1F	F03	16	12,80	12,20	16,0	16	9	16	4	0,006
16T2,5/18-2	16T2018	6F	F04	18	14,40	13,80	17,5	10	10	16	4	0,006
16T2,5/19-2	16T2019	6F	F05	19	15,20	14,60	18,0	10	10	16	4	0,007
16T2,5/20-2	16T2020	6F	F06	20	16,00	15,40	20,0	11	10	16	4	0,008
16T2,5/22-2	16T2022	6F	F07	22	16,60	17,00	23,0	11	10	16	4	0,010
16T2,5/24-2	16T2024	6F	F07	24	19,15	18,55	23,0	12	10	16	4	0,012
16T2,5/25-2	16T2025	6F	F07	25	19,95	19,35	23,0	13	10	16	4	0,013
16T2,5/26-2	16T2026	6F	F09	26	20,75	20,15	25,0	14	10	16	4	0,015
16T2,5/28-2	16T2028	6F	F09	28	22,35	21,75	25,0	14	10	16	4	0,016
16T2,5/30-2	16T2030	6F	F09	30	23,95	23,35	28,0	16	10	16	6	0,018
16T2,5/32-2	16T2032	6F	F10	32	25,95	24,95	32,0	16	10	16	6	0,020
16T2,5/36-2	16T2036	6F	F12	36	28,75	28,10	36,0	20	10	16	6	0,026
16T2,5/40-2	16T2040	6F	F14	40	31,90	31,30	38,0	22	10	16	6	0,032
16T2,5/44-0	16T2044	6F	F15	44	35,10	34,50	42,0	24	10	16	6	0,038
16T2,5/48-0	16T2048	6	—	48	38,30	37,70	—	26	10	16	6	0,048
16T2,5/60-0	16T2060	6	—	60	47,85	47,25	—	34	10	16	8	0,073

PER PULEGGE AVENTI UN NUMERO DI DENTI DIVERSO DALLA TABELLA, CONSULTATECI.
 FOR PULLEYS WITH A NUMBER OF TEETH NOT INCLUDED IN THESE TABLES PLEASE ASK FOR OUR QUOTATION.
 VERLAGEN SIE ANGEBOUOT FUER ZAHNSCHEIBEN MIT ANZHAL VON ZAEHNEN DIE NICHT IN DIESEN TAFELN AUFGEFUEHRT SIND.
 POUR LES POULIES AVEC UN NOMBRE DE DENTS DIFFERENT DU TABLEAU, NOUS CONSULTER.
 PIDAN OFERTA POR LO QUE CONCIERNE UNA CANTIDAD DE DIENTES NO INCLUIDA EN ESTAS TABLAS.

Pulegge dentate per cinghie passo metrico
Timing belt pulleys metric pitch
Zahnriemenscheiben metrische Teilung
Poulies dentées pour courroies pas métrique
Poleas dentadas para correas con paso en mm

Materiale: alluminio 6082 T6 UNI 9006/4 adatto al trattamento anodico

Material: aluminium 6082 T6 UNI 9006/4 suitable for anodic treatment

Material: aluminium 6082 T6 UNI 9006/4 geeignet für anodischen oxydation

Material: aluminium 6082 T6 UNI 9006/4 apte au traitement anodique

Material: aluminio 6082 T6 UNI 9006/4 apto para la oxidacion anodica

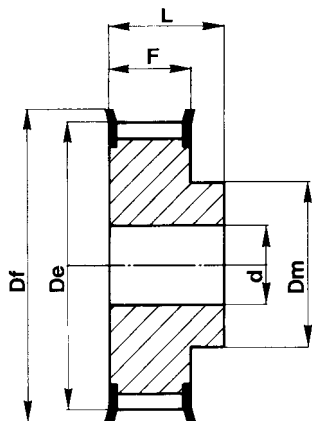

TIPO TYPE 6F

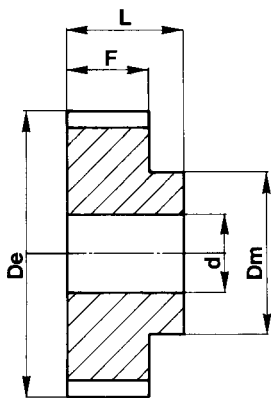

TIPO TYPE 6

(PASSO 5 mm) PER CINGHIA LARGHEZZA 10 mm
(PITCH 5 mm) FOR BELT WIDTH 10 mm
(Teilung 5 mm) fuer RIEMENBREITE 10 mm
(PAS 5 mm) POUR COURROIES LARGEUR 10 mm
(PASO 5 mm) PARA CORREAS ANCHO 10 mm

T 5

CODICE CODE SYMBOL FABRIKNUMMER CODE SYMBOLE NUMERO DE FABRICA	NOSTRO CODICE OUR CODE UNSER KODE NOTRE CODE NUESTRO CODIGO	TIPO TYPE TYP TYPE TIPO	TIPO FLANGIA FLANGES TYPE BORDSCHEIBEN TYP TYPE FLASQUES TIPO TAPETAS	N.DENTI N. OF TEETH ZAHNEZAHL N. BRE DE DENTS CANTIDAD DE DIENTES	Dp	De	Df	Dm	F	L	d	PESO WEIGHT GEWICHT POIDS PESO Kg
21T5/10-2	21T5010	6F	F06	10	16,05	15,05	20,0	8	15	21	4	0,012
21T5/12-2	21T5012	6F	F07	12	19,25	18,25	23,0	11	15	21	4	0,016
21T5/14-2	21T5014	6F	F08	14	22,45	21,45	25,0	13	15	21	4	0,019
21T5/15-2	21T5015	6F	F09	15	24,05	23,05	28,0	16	15	21	6	0,021
21T5/16-2	21T5016	6F	F10	16	25,06	24,60	32,0	18	15	21	6	0,025
21T5/18-2	21T5018	6F	F10	18	28,80	27,80	32,0	20	15	21	6	0,031
21T5/19-2	21T5019	6F	F12	19	30,40	29,40	36,0	22	15	21	6	0,036
21T5/20-2	21T5020	6F	F12	20	32,00	31,00	36,0	23	15	21	6	0,038
21T5/22-2	21T5022	6F	F14	22	35,15	34,15	38,0	24	15	21	6	0,054
21T5/24-2	21T5024	6F	F15	24	38,40	37,40	42,0	26	15	21	6	0,056
21T5/25-2	21T5025	6F	F17	25	39,95	38,95	44,0	26	15	21	6	0,058
21T5/26-2	21T5026	6F	F17	26	41,60	40,60	44,0	26	15	21	6	0,064
21T5/27-2	21T5027	6F	F18	27	43,20	42,20	48,0	30	15	21	8	0,070
21T5/28-2	21T5028	6F	F18	28	44,75	43,75	48,0	32	15	21	8	0,075
21T5/30-2	21T5030	6F	F19	30	47,95	46,95	51,0	34	15	21	8	0,081
21T5/32-2	21T5032	6F	F20	32	51,10	50,10	54,0	38	15	21	8	0,088
21T5/36-2	21T5036	6F	F24	36	57,45	56,45	64,0	38	15	21	8	0,114
21T5/40-2	21T5040	6F	F25	40	63,85	62,85	66,0	40	15	21	8	0,138
21T5/42-2	21T5042	6F	F26	42	67,00	66,00	70,0	40	15	21	8	0,165
21T5/44-0	21T5044	6	—	44	70,20	69,20	—	45	15	21	8	0,200
21T5/48-0	21T5048	6	—	48	76,55	75,55	—	50	15	21	8	0,307
21T5/60-0	21T5060	6	—	60	95,65	94,65	—	65	15	21	8	0,180

(PASSO 5 mm) PER CINGHIA LARGHEZZA 16 mm
(PITCH 5 mm) FOR BELT WIDTH 16 mm
(Teilung 5 mm) fuer RIEMENBREITE 16 mm
(PAS 5 mm) POUR COURROIES LARGEUR 16 mm
(PASO 5 mm) PARA CORREAS ANCHO 16 mm

T 5

CODICE CODE SYMBOL FABRIKNUMMER CODE SYMBOLE NUMERO DE FABRICA	NOSTRO CODICE OUR CODE UNSER KODE NOTRE CODE NUESTRO CODIGO	TIPO TYPE TYP TYPE TIPO	TIPO FLANGIA FLANGES TYPE BORDSCHEIBEN TYP TYPE FLASQUES TIPO TAPETAS	N.DENTI N. OF TEETH ZAHNEZAHL N. BRE DE DENTS CANTIDAD DE DIENTES	Dp	De	Df	Dm	F	L	d	PESO WEIGHT GEWICHT POIDS PESO Kg
27T5/10-2	27T5010	6F	F06	10	16,05	15,05	20,0	8	21	27	4	0,016
27T5/12-2	27T5012	6F	F07	12	19,25	18,25	23,0	11	21	27	4	0,022
27T5/14-2	27T5014	6F	F08	14	22,45	21,45	25,0	13	21	27	4	0,026
27T5/15-2	27T5015	6F	F09	15	24,05	23,05	28,0	16	21	27	6	0,029
27T5/16-2	27T5016	6F	F10	16	25,06	24,60	32,0	18	21	27	6	0,035
27T5/18-2	27T5018	6F	F10	18	28,80	27,80	32,0	20	21	27	6	0,043
27T5/19-2	27T5019	6F	F12	19	30,40	29,40	36,0	22	21	27	6	0,049
27T5/20-2	27T5020	6F	F12	20	32,00	31,00	36,0	23	21	27	6	0,053
27T5/22-2	27T5022	6F	F14	22	35,15	34,15	38,0	24	21	27	6	0,062
27T5/24-2	27T5024	6F	F15	24	38,40	37,40	42,0	26	21	27	6	0,076
27T5/25-2	27T5025	6F	F17	25	39,95	38,95	44,0	26	21	27	6	0,081
27T5/26-2	27T5026	6F	F17	26	41,60	40,60	44,0	26	21	27	6	0,085
27T5/27-2	27T5027	6F	F18	27	43,20	42,20	48,0	30	21	27	8	0,090
27T5/28-2	27T5028	6F	F18	28	44,75	43,75	48,0	32	21	27	8	0,095
27T5/30-2	27T5030	6F	F19	30	47,95	46,95	51,0	34	21	27	8	0,105
27T5/32-2	27T5032	6F	F20	32	51,10	50,10	54,0	38	21	27	8	0,123
27T5/36-2	27T5036	6F	F24	36	57,45	56,45	64,0	38	21	27	8	0,160
27T5/40-2	27T5040	6F	F25	40	63,85	62,85	66,0	40	21	27	8	0,193
27T5/42-2	27T5042	6F	F26	42	67,00	66,00	70,0	40	21	27	8	0,245
27T5/44-0	27T5044	6	—	44	70,20	69,20	—	45	21	27	8	0,280
27T5/48-0	27T5048	6	—	48	76,55	75,55	—	50	21	27	8	0,430
27T5/60-0	27T5060	6	—	60	95,65	94,65	—	65	21	27	8	0,108

(PASSO 5 mm) PER CINGHIA LARGHEZZA 25 mm
(PITCH 5 mm) FOR BELT WIDTH 25 mm
(Teilung 5 mm) fuer RIEMENBREITE 25 mm
(PAS 5 mm) POUR COURROIES LARGEUR 25 mm
(PASO 5 mm) PARA CORREAS ANCHO 25 mm

T 5

CODICE CODE SYMBOL FABRIKNUMMER CODE SYMBOLE NUMERO DE FABRICA	NOSTRO CODICE OUR CODE UNSER KODE NOTRE CODE NUESTRO CODIGO	TIPO TYPE TYP TYPE TIPO	TIPO FLANGIA FLANGES TYPE BORDSCHEIBEN TYP TYPE FLASQUES TIPO TAPETAS	N.DENTI N. OF TEETH ZAHNEZAHL N. BRE DE DENTS CANTIDAD DE DIENTES	Dp	De	Df	Dm	F	L	d	PESO WEIGHT GEWICHT POIDS PESO Kg
36T5/10-2	36T5010	6F	F06	10	16,05	15,05	20,0	8	30	36	4	0,023
36T5/12-2	36T5012	6F	F07	12	19,25	18,25	23,0	11	30	36	4	0,031
36T5/14-2	36T5014	6F	F08	14	22,45	21,45	25,0	13	30	36	4	0,037
36T5/15-2	36T5015	6F	F09	15	24,05	23,05	28,0	16	30	36	6	0,041
36T5/16-2	36T5016	6F	F10	16	25,06	24,60	32,0	18	30	36	6	0,050
36T5/18-2	36T5018	6F	F10	18	28,80	27,80	32,0	20	30	36	6	0,061
36T5/19-2	36T5019	6F	F12	19	30,40	29,40	36,0	22	30	36	6	0,070
36T5/20-2	36T5020	6F	F12	20	32,00	31,00	36,0	23	30	36	6	0,076
36T5/22-2	36T5022	6F	F14	22	35,15	34,15	38,0	24	30	36	6	0,092
36T5/24-2	36T5024	6F	F15	24	38,40	37,40	42,0	26	30	36	8	0,109
36T5/25-2	36T5025	6F	F17	25	39,95	38,95	44,0	26	30	36	8	0,116
36T5/26-2	36T5026	6F	F17	26	41,60	40,60	44,0	26	30	36	8	0,121
36T5/27-2	36T5027	6F	F18	27	43,20	42,20	48,0	30	30	36	8	0,128
36T5/28-2	36T5028	6F	F18	28	44,75	43,75	48,0	32	30	36	8	0,142
36T5/30-2	36T5030	6F	F19	30	47,95	46,95	51,0	34	30	36	8	0,150
36T5/32-2	36T5032	6F	F20	32	51,10	50,10	54,0	38	30	36	8	0,176
36T5/36-2	36T5036	6F	F24	36	57,45	56,45	64,0	38	30	36	8	0,230
36T5/40-2	36T5040	6F	F25	40	63,85	62,85	66,0	40	30	36	8	0,276
36T5/42-2	36T5042	6F	F26	42	67,00	66,00	70,0	40	30	36	8	0,352
36T5/44-0	36T5044	6	—	44	70,20	69,20	—	45	30	36	8	0,400
36T5/48-0	36T5048	6	—	48	76,55	75,55	—	50	30	36	8	0,614
36T5/60-0	36T5060	6	—	60	95,65	94,65	—	65	30	36	8	0,180

Pulegge dentate per cinghie passo metrico
Timing belt pulleys metric pitch
Zahnriemenscheiben metrische Teilung
Poulies dentées pour courroies pas métrique
Poleas dentadas para correas con paso en mm

Materiale: alluminio 6082 T6 UNI 9006/4 adatto al trattamento anodico

Material: aluminium 6082 T6 UNI 9006/4 suitable for anodic treatment

Material: aluminium 6082 T6 UNI 9006/4 geeignet für anodischen oxydation

Material: aluminium 6082 T6 UNI 9006/4 apte au traitement anodique

Material: aluminio 6082 T6 UNI 9006/4 apto para la oxidacion anodica

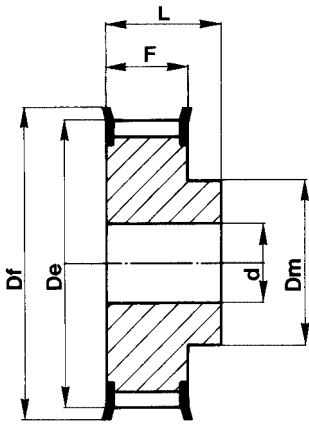

TIPO 6F
TYPE 6F

(PASSO 10 mm) PER CINGHIA LARGHEZZA 16 mm
 (PITCH 10 mm) FOR BELT WIDTH 16 mm
 (TEILUNG 10 mm) FUER RIEMENBREITE 16 mm
 (PAS 10 mm) POUR COURROIES LARGEUR 16 mm
 (PASO 10 mm) PARA CORREAS ANCHO 16 mm

T 10

CODICE CODE SYMBOL FABRIKNUMMER CODE SYMBOLE NUMERO DE FABRICA	NOSTRO CODICE OUR CODE UNSER KODE NOTRE CODE NUESTRO CODIGO	TIPO TYPE TYP TYPE TIPO	TIPO FLANGIA FLANGES TYPE BORDSCHEIBEN TYP TYPE FLASQUES TIPO TAPETAS	N.DENTI N. OF TEETH ZAHNEZAHL N. BRE DE DENTS CANTIDAD DE DIENTES	Dp	De	Df	Dm	F	L	d	PESO WEIGHT GEWICHT POIDS PESO Kg
31T10/12-2	31T1012	6F	F15	12	38,35	36,35	42	28	21	31	6	0,076
31T10/14-2	31T1014	6F	F18	14	44,70	42,70	48	32	21	31	8	0,104
31T10/15-2	31T1015	6F	F19	15	47,90	45,90	51	32	21	31	8	0,116
31T10/16-2	31T1016	6F	F20	16	51,10	49,10	54	35	21	31	8	0,134
31T10/18-2	31T1018	6F	F22	18	57,45	55,45	60	40	21	31	8	0,167
31T10/19-2	31T1019	6F	F25	19	60,65	58,65	66	44	21	31	8	0,184
31T10/20-2	31T1020	6F	F25	20	63,80	61,80	66	46	21	31	8	0,208
31T10/22-2	31T1022	6F	F27	22	70,20	68,20	75	52	21	31	8	0,240
31T10/24-2	31T1024	6F	F29	24	76,55	74,55	83	58	21	31	8	0,288
31T10/25-2	31T1025	6F	F29	25	79,75	77,75	83	60	21	31	8	0,295
31T10/26-2	31T1026	6F	F30	26	82,90	80,90	87	60	21	31	8	0,310
31T10/27-2	31T1027	6F	F31	27	86,10	84,10	91	60	21	31	8	0,364
31T10/28-2	31T1028	6F	F32	28	89,25	87,25	93	60	21	31	8	0,441
31T10/30-2	31T1030	6F	F33	30	95,65	93,65	97	60	21	31	8	0,493
31T10/32-2	31T1032	6F	F35	32	102,00	100,00	106	65	21	31	10	0,623
31T10/36-2	31T1036	6F	F38	36	114,75	112,75	120	70	21	31	10	0,767
31T10/40-2	31T1040	6F	F41	40	127,45	125,45	131	80	21	31	10	0,950
31T10/44-0	31T1044	6	—	44	140,20	138,20	—	88	21	31	10	1,090
31T10/48-0	31T1048	6	—	48	152,95	150,95	—	95	21	31	16	1,704
31T10/60-0	31T1060	6	—	60	191,15	189,10	—	110	21	31	16	1,704

(PASSO 10 mm) PER CINGHIA LARGHEZZA 25 mm
 (PITCH 10 mm) FOR BELT WIDTH 25 mm
 (TEILUNG 10 mm) FUER RIEMENBREITE 25 mm
 (PAS 10 mm) POUR COURROIES LARGEUR 25 mm
 (PASO 10 mm) PARA CORREAS ANCHO 25 mm

T 10

CODICE CODE SYMBOL FABRIKNUMMER CODE SYMBOLE NUMERO DE FABRICA	NOSTRO CODICE OUR CODE UNSER KODE NOTRE CODE NUESTRO CODIGO	TIPO TYPE TYP TYPE TIPO	TIPO FLANGIA FLANGES TYPE BORDSCHEIBEN TYP TYPE FLASQUES TIPO TAPETAS	N.DENTI N. OF TEETH ZAHNEZAHL N. BRE DE DENTS CANTIDAD DE DIENTES	Dp	De	Df	Dm	F	L	d	PESO WEIGHT GEWICHT POIDS PESO Kg
40T10/12-2	40T1012	6F	F15	12	38,35	36,35	42	28	30	40	6	0,099
40T10/14-2	40T1014	6F	F18	14	44,70	42,70	48	32	30	40	8	0,134
40T10/15-2	40T1015	6F	F19	15	47,90	45,90	51	32	30	40	8	0,152
40T10/16-2	40T1016	6F	F20	16	51,10	49,10	54	35	30	40	8	0,176
40T10/18-2	40T1018	6F	F22	18	57,45	55,45	60	40	30	40	8	0,224
40T10/19-2	40T1019	6F	F25	19	60,65	58,65	66	44	30	40	8	0,247
40T10/20-2	40T1020	6F	F25	20	63,80	61,80	66	46	30	40	8	0,276
40T10/22-2	40T1022	6F	F27	22	70,20	68,20	75	52	30	40	8	0,310
40T10/24-2	40T1024	6F	F29	24	76,55	74,55	83	58	30	40	8	0,392
40T10/25-2	40T1025	6F	F29	25	79,75	77,75	83	60	30	40	8	0,422
40T10/26-2	40T1026	6F	F30	26	82,90	80,90	87	60	30	40	8	0,480
40T10/27-2	40T1027	6F	F31	27	86,10	84,10	91	60	30	40	8	0,536
40T10/28-2	40T1028	6F	F32	28	89,25	87,25	93	60	30	40	8	0,590
40T10/30-2	40T1030	6F	F33	30	95,65	93,65	97	60	30	40	8	0,640
40T10/32-2	40T1032	6F	F35	32	102,00	100,00	106	65	30	40	10	0,693
40T10/36-2	40T1036	6F	F38	36	114,75	112,75	120	70	30	40	10	0,873
40T10/40-2	40T1040	6F	F41	40	127,45	125,45	131	80	30	40	10	1,067
40T10/44-0	40T1044	6	—	44	140,20	138,20	—	88	30	40	10	1,310
40T10/48-0	40T1048	6	—	48	152,95	150,95	—	95	30	40	16	1,516
40T10/60-0	40T1060	6	—	60	191,15	189,10	—	110	30	40	16	2,339

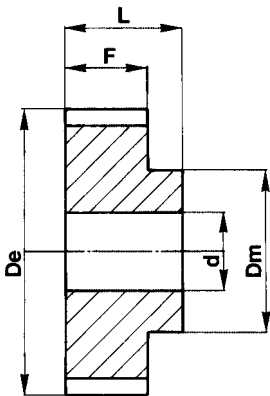

TIPO 6
TYPE 6

Pulegge dentate per cinghie passo metrico
Timing belt pulleys metric pitch
Zahnriemenscheiben metrische Teilung
Poulies dentées pour courroies pas métrique
Poleas dentadas para correas con paso en mm

Materiale: alluminio 6082 T6 UNI 9006/4 adatto al trattamento anodico

Material: aluminium 6082 T6 UNI 9006/4 suitable for anodic treatment

Material: aluminium 6082 T6 UNI 9006/4 geeignet für anodischen oxydation

Material: aluminium 6082 T6 UNI 9006/4 apte au traitement anodique

Material: aluminio 6082 T6 UNI 9006/4 apto para la oxidacion anodica

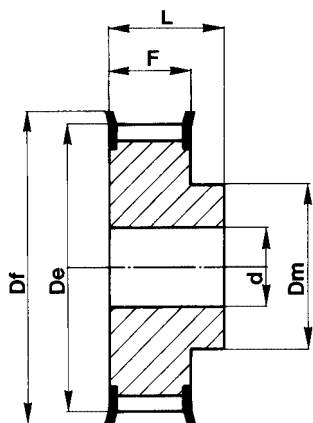

TIPO 6F
TYPE 6F

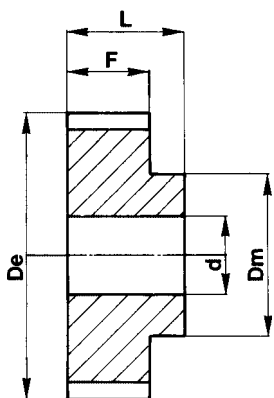

TIPO 6
TYPE 6

(PASSO 10 mm) PER CINGHIA LARGHEZZA 32 mm
(PITCH 10 mm) FOR BELT WIDTH 32 mm
(Teilung 10 mm) FUER RIEMENBREITE 32 mm
(PAS 10 mm) POUR COURROIES LARGEUR 32 mm
(PASO 10 mm) PARA CORREAS ANCHO 32 mm

T 10

CODICE CODE SYMBOL FABRIKNUMMER CODE SYMBOLE NUMERO DE FABRICA	NOSTRO CODICE OUR CODE UNSER KODE NOTRE CODE NUESTRO CODIGO	TIPO TYPE TYP TYPE TIPO	TIPO FLANGIA FLANGES TYPE BORDSCHEIBEN TYP TYPE FLASQUES TIPO TAPETAS	N.DENTI N. OF TEETH ZAHNEZAHL N. BRE DE DENTS CANTIDAD DE DIENTES	Dp	De	Df	Dm	F	L	d	PESO WEIGHT GEWICHT POIDS PESO Kg
47T10/18-2	47T1018	6F	F22	18	57,45	55,45	60	40	37	47	10	0,253
47T10/19-2	47T1019	6F	F25	19	60,65	58,65	66	44	37	47	10	0,286
47T10/20-2	47T1020	6F	F25	20	63,80	61,80	66	46	37	47	12	0,322
47T10/22-2	47T1022	6F	F27	22	70,20	68,20	75	52	37	47	12	0,393
47T10/24-2	47T1024	6F	F29	24	76,55	74,55	83	58	37	47	12	0,475
47T10/25-2	47T1025	6F	F29	25	79,75	77,70	83	60	37	47	12	0,527
47T10/26-2	47T1026	6F	F30	26	82,90	80,90	87	60	37	47	12	0,564
47T10/27-2	47T1027	6F	F31	27	86,10	84,10	91	60	37	47	12	0,602
47T10/28-2	47T1028	6F	F32	28	89,25	87,25	93	60	37	47	12	0,642
47T10/30-2	47T1030	6F	F33	30	95,65	93,65	97	60	37	47	12	0,740
47T10/32-2	47T1032	6F	F35	32	102,00	100,00	106	65	37	47	12	0,844
47T10/36-2	47T1036	6F	F38	36	114,75	112,45	120	70	37	47	16	1,063
47T10/40-2	47T1040	6F	F41	40	127,45	125,45	131	80	37	47	16	1,371
47T10/44-0	47T1044	6	—	44	140,20	138,20	—	88	37	47	16	1,611
47T10/48-0	47T1048	6	—	48	152,95	150,95	—	95	37	47	16	1,913
47T10/60-0	47T1060	6	—	60	191,10	189,10	—	110	37	47	16	3,004

(PASSO 10 mm) PER CINGHIA LARGHEZZA 50 mm
(PITCH 10 mm) FOR BELT WIDTH 50 mm
(Teilung 10 mm) FUER RIEMENBREITE 50 mm
(PAS 10 mm) POUR COURROIES LARGEUR 50 mm
(PASO 10 mm) PARA CORREAS ANCHO 50 mm

T 10

CODICE CODE SYMBOL FABRIKNUMMER CODE SYMBOLE NUMERO DE FABRICA	NOSTRO CODICE OUR CODE UNSER KODE NOTRE CODE NUESTRO CODIGO	TIPO TYPE TYP TYPE TIPO	TIPO FLANGIA FLANGES TYPE BORDSCHEIBEN TYP TYPE FLASQUES TIPO TAPETAS	N.DENTI N. OF TEETH ZAHNEZAHL N. BRE DE DENTS CANTIDAD DE DIENTES	Dp	De	Df	Dm	F	L	d	PESO WEIGHT GEWICHT POIDS PESO Kg
66T10/18-2	66T1018	6F	F22	18	57,45	55,45	60	40	56	66	10	0,422
66T10/19-2	66T1019	6F	F25	19	60,65	58,65	66	44	56	66	10	0,466
66T10/20-2	66T1020	6F	F25	20	63,80	61,80	66	46	56	66	12	0,520
66T10/22-2	66T1022	6F	F27	22	70,20	68,20	75	52	56	66	12	0,640
66T10/24-2	66T1024	6F	F29	24	76,55	74,55	83	58	56	66	12	0,736
66T10/25-2	66T1025	6F	F29	25	79,75	77,70	83	60	56	66	12	0,766
66T10/26-2	66T1026	6F	F30	26	82,90	80,90	87	60	56	66	12	0,845
66T10/27-2	66T1027	6F	F31	27	86,10	84,10	91	60	56	66	12	0,946
66T10/28-2	66T1028	6F	F32	28	89,25	87,25	93	60	56	66	12	0,110
66T10/30-2	66T1030	6F	F33	30	95,65	93,65	97	60	56	66	12	1,169
66T10/32-2	66T1032	6F	F35	32	102,00	100,00	106	65	56	66	12	1,300
66T10/36-2	66T1036	6F	F38	36	114,75	112,75	120	70	56	66	16	1,637
66T10/40-2	66T1040	6F	F41	40	127,45	125,45	131	80	56	66	16	1,999
66T10/44-0	66T1044	6	—	44	140,20	138,20	—	88	56	66	16	2,420
66T10/48-0	66T1048	6	—	48	152,95	150,95	—	95	56	66	16	2,830
66T10/60-0	66T1060	6	—	60	191,10	189,10	—	110	56	66	16	4,366

Pulegge dentate per cinghie passo metrico
Timing belt pulleys metric pitch
Zahnriemenscheiben metrische Teilung
Poulies dentées pour courroies pas métrique
Poleas dentadas para correas con paso en mm

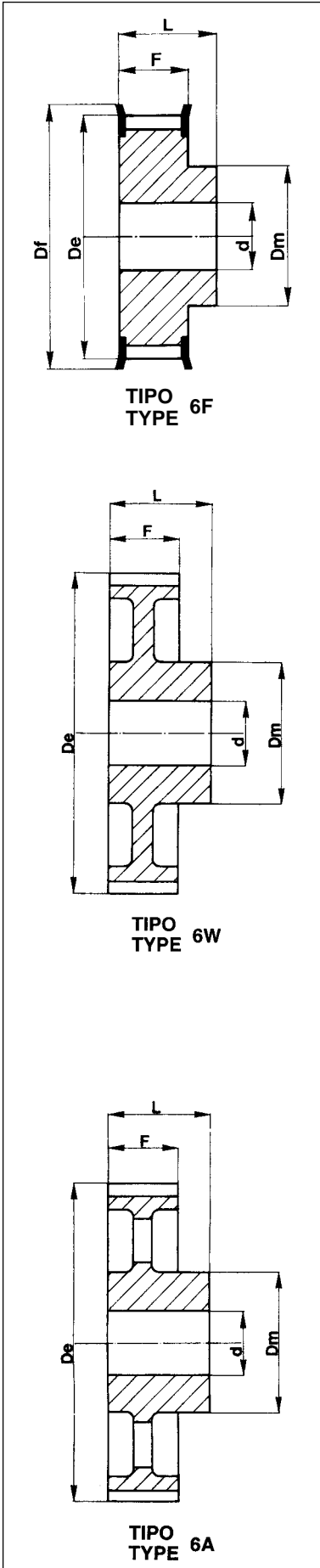

(PASSO 20 mm) PER CINGHIA LARGHEZZA 32 mm
(PITCH 20 mm) FOR BELT WIDTH 32 mm
(Teilung 20 mm) fuer RIEMENBREITE 32 mm
(PAS 20 mm) POUR COURROIES LARGEUR 32 mm
(PASO 20 mm) PARA CORREAS ANCHO 32 mm

T 20

	CODICE CODE SYMBOL FABRIKNUMMER CODE SYMBOLE NUMERO DE FABRICA	NOSTRO CODICE OUR CODE UNSER KODE NOTRE CODE NUESTRO CODIGO	TIPO TYPE TYP TYPE TIPO	TIPO FLANGIA FLANGES TYPE BORDSCHEIBEN TYP TYPE FLASQUES TIPO TAPETAS	N.DENTI N. OF TEETH ZAHNEZAHL N. BRE DE DENTS CANTIDAD DE DIENTES	De	Df	Dm	F	L	d	PESO WEIGHT GEWICHT POIDS PESO Kg
GHISA - CAST IRON - GUESSEISEN FONTE - FUNDICION	53T20/18-2	53T2018	6F	F38	18	111,75	120	80	38	53	15	
	53T20/20-2	53T2020	6F	F43	20	124,50	138	90	38	53	15	
	53T20/22-2	53T2022	6F	F46	22	137,20	146	90	38	53	15	
	53T20/24-2	53T2024	6F	F50	24	149,95	158	95	38	53	15	
	53T20/25-2	53T2025	6F	F52	25	156,30	168	95	38	53	15	
	53T20/30-2	53T2030	6F	F59	30	188,15	200	110	38	53	15	
	53T20/32-2	53T2032	6W		32	200,85	-	110	38	53	18	
	53T20/36-2	53T2036	6W		36	226,35	-	110	38	53	18	
	53T20/40-2	53T2040	6A		40	251,80	-	110	38	53	20	
	53T20/48-2	53T2048	6A		48	302,70	-	130	38	53	20	
	53T20/60-2	53T2060	6A		60	379,10	-	130	38	53	20	
	53T20/72-2	53T2072	6A		72	455,50	-	140	38	53	20	

(PASSO 20 mm) PER CINGHIA LARGHEZZA 50 mm
(PITCH 20 mm) FOR BELT WIDTH 50 mm
(Teilung 20 mm) fuer RIEMENBREITE 50 mm
(PAS 20 mm) POUR COURROIES LARGEUR 50 mm
(PASO 20 mm) PARA CORREAS ANCHO 50 mm

T 20

	CODICE CODE SYMBOL FABRIKNUMMER CODE SYMBOLE NUMERO DE FABRICA	NOSTRO CODICE OUR CODE UNSER KODE NOTRE CODE NUESTRO CODIGO	TIPO TYPE TYP TYPE TIPO	TIPO FLANGIA FLANGES TYPE BORDSCHEIBEN TYP TYPE FLASQUES TIPO TAPETAS	N.DENTI N. OF TEETH ZAHNEZAHL N. BRE DE DENTS CANTIDAD DE DIENTES	De	Df	Dm	F	L	d	PESO WEIGHT GEWICHT POIDS PESO Kg
GHISA - CAST IRON - GUESSEISEN FONTE - FUNDICION	71T20/18-2	71T2018	6F	F38	18	111,75	120	80	56	71	18	
	71T20/20-2	71T2020	6F	F43	20	124,50	138	90	56	71	18	
	71T20/22-2	71T2022	6F	F46	22	137,20	146	90	56	71	18	
	71T20/24-2	71T2024	6F	F50	24	149,95	158	95	56	71	18	
	71T20/25-2	71T2025	6F	F52	25	156,30	168	95	56	71	18	
	71T20/30-2	71T2030	6F	F59	30	188,15	200	110	56	71	18	
	71T20/32-2	71T2032	6W		32	200,85	-	110	56	71	20	
	71T20/36-2	71T2036	6W		36	226,35	-	110	56	71	20	
	71T20/40-2	71T2040	6A		40	251,80	-	110	56	71	20	
	71T20/48-2	71T2048	6A		48	302,70	-	130	56	71	24	
	71T20/60-2	71T2060	6A		60	379,10	-	130	56	71	24	
	71T20/72-2	71T2072	6A		72	455,50	-	140	56	71	24	

(PASSO 20 mm) PER CINGHIA LARGHEZZA 100 mm
(PITCH 20 mm) FOR BELT WIDTH 100 mm
(Teilung 20 mm) fuer RIEMENBREITE 100 mm
(PAS 20 mm) POUR COURROIES LARGEUR 100 mm
(PASO 20 mm) PARA CORREAS ANCHO 100 mm

T 20

	CODICE CODE SYMBOL FABRIKNUMMER CODE SYMBOLE NUMERO DE FABRICA	NOSTRO CODICE OUR CODE UNSER KODE NOTRE CODE NUESTRO CODIGO	TIPO TYPE TYP TYPE TIPO	TIPO FLANGIA FLANGES TYPE BORDSCHEIBEN TYP TYPE FLASQUES TIPO TAPETAS	N.DENTI N. OF TEETH ZAHNEZAHL N. BRE DE DENTS CANTIDAD DE DIENTES	De	Df	Dm	F	L	d	PESO WEIGHT GEWICHT POIDS PESO Kg
GHISA - CAST IRON - GUESSEISEN FONTE - FUNDICION	123T20/18-2	123T2018	6F	F38	18	111,75	120	80	108	123	24	
	123T20/20-2	123T2020	6F	F43	20	124,50	138	90	108	123	24	
	123T20/22-2	123T2022	6F	F46	22	137,20	146	90	108	123	24	
	123T20/24-2	123T2024	6F	F50	24	149,95	158	95	108	123	24	
	123T20/25-2	123T2025	6F	F52	25	156,30	168	95	108	123	24	
	123T20/30-2	123T2030	6F	F59	30	188,15	200	110	108	123	24	
	123T20/32-2	123T2032	6W		32	200,85	-	110	108	123	32	
	123T20/36-2	123T2036	6W		36	226,35	-	110	108	123	32	
	123T20/40-2	123T2040	6A		40	251,80	-	110	108	123	32	
	123T20/48-2	123T2048	6A		48	302,70	-	130	108	123	32	
	123T20/60-2	123T2060	6A		60	379,10	-	130	108	123	32	
	123T20/72-2	123T2072	6A		72	455,50	-	140	108	123	32	

Barre dentate standard
Standard toothed bars
Standard Zahnriemensstagen
Barreaux dentés standard
Barras dentadas de serie

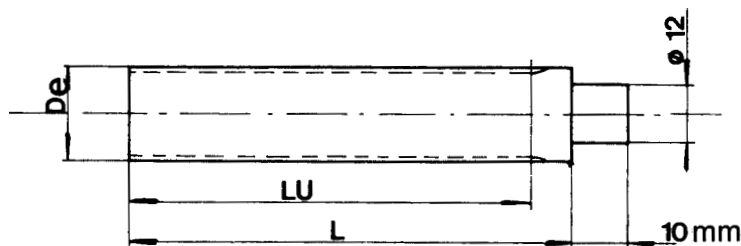

Materiale: alluminio 6082 T6 UNI 9006/4 adatto al trattamento anodico
Material: aluminium 6082 T6 UNI 9006/4 suitable for anodic treatment
Material: aluminium 6082 T6 UNI 9006/4 geeignet für anodischen oxydation
Material: aluminium 6082 T6 UNI 9006/4 apte au traitement anodique
Material: aluminio 6082 T6 UNI 9006/4 apto para la oxidacion anodica

T 2,5 (PASSO 2,5 mm) (PITCH 2,5 mm) (TEILUNG 2,5 mm) (PAS 2,5 mm) (PASO 2,5 mm)				T 5 (PASSO 5 mm) (PITCH 5 mm) (TEILUNG 5 mm) (PAS 5 mm) (PASO 5 mm)				T 10 (PASSO 10 mm) (PITCH 10 mm) (TEILUNG 10 mm) (PAS 10 mm) (PASO 10 mm)									
CODICE CODE SYMBOL FABRIKNUMMER CODE SYMBOLE NUMERO DE FABRICA	NOSTRO CODICE OUR CODE UNSER KODE NOTRE CODE NUESTRO CODIGO	N.DENTI N. OF TEETH ZAHNEZAHL N. BRE DE DENTS CANTIDAD DE DIENTES	De	Lu	L	CODICE CODE SYMBOL FABRIKNUMMER CODE SYMBOLE NUMERO DE FABRICA	NOSTRO CODICE OUR CODE UNSER KODE NOTRE CODE NUESTRO CODIGO	N.DENTI N. OF TEETH ZAHNEZAHL N. BRE DE DENTS CANTIDAD DE DIENTES	De	Lu	L	CODICE CODE SYMBOL FABRIKNUMMER CODE SYMBOLE NUMERO DE FABRICA	NOSTRO CODICE OUR CODE UNSER KODE NOTRE CODE NUESTRO CODIGO	N.DENTI N. OF TEETH ZAHNEZAHL N. BRE DE DENTS CANTIDAD DE DIENTES	De	Lu	L
T2,5-10	BT25010	10	7,42	50	75	T5-10	BT05010	10	15,05	125	140	T10-10	BT10010	10	29,98	140	140
T2,5-12	BT25012	12	9,00	50	75	T5-11	BT05011	11	16,65	125	140	T10-11	BT10011	11	33,16	140	140
T2,5-13	BT25013	13	9,80	50	75	T5-12	BT05012	12	18,25	125	140	T10-12	BT10012	12	36,35	140	140
T2,5-14	BT25014	14	10,60	50	75	T5-13	BT05013	13	19,85	125	140	T10-13	BT10013	13	39,50	140	140
T2,5-15	BT25015	15	11,40	50	75	T5-14	BT05014	14	21,45	132	140	T10-14	BT10014	14	42,70	160	160
T2,5-16	BT25016	16	12,20	50	75	T5-15	BT05015	15	23,05	132	140	T10-15	BT10015	15	45,90	160	160
T2,5-17	BT25017	17	13,00	50	75	T5-16	BT05016	16	24,60	140	140	T10-16	BT10016	16	49,10	160	160
T2,5-18	BT25018	18	13,80	50	75	T5-17	BT05017	17	26,20	140	140	T10-17	BT10017	17	52,25	160	160
T2,5-19	BT25019	19	14,60	90	120	T5-18	BT05018	18	27,80	140	140	T10-18	BT10018	18	55,45	160	160
T2,5-20	BT25020	20	15,40	90	120	T5-19	BT05019	19	29,40	140	140	T10-19	BT10019	19	58,65	160	160
T2,5-21	BT25021	21	16,20	90	120	T5-20	BT05020	20	31,00	160	160	T10-20	BT10020	20	61,80	160	160
T2,5-22	BT25022	22	17,00	125	140	T5-21	BT05021	21	32,70	160	160	T10-21	BT10021	21	65,00	160	160
T2,5-24	BT25024	24	18,55	125	140	T5-22	BT05022	22	34,15	160	160	T10-22	BT10022	22	68,20	160	160
T2,5-26	BT25026	26	20,15	125	140	T5-23	BT05023	23	35,85	160	160	T10-23	BT10023	23	71,35	160	160
T2,5-27	BT25027	27	20,95	125	140	T5-24	BT05024	24	37,40	160	160	T10-24	BT10024	24	74,55	160	160
T2,5-28	BT25028	28	21,75	125	140	T5-25	BT05025	25	38,95	160	160	T10-26	BT10026	26	80,90	160	160
T2,5-29	BT25029	29	22,55	125	140	T5-26	BT05026	26	40,60	160	160	T10-28	BT10028	28	87,25	160	160
T2,5-30	BT25030	30	23,35	125	140	T5-27	BT05027	27	42,20	160	160	T10-30	BT10030	30	93,65	160	160
T2,5-32	BT25032	32	24,95	125	140	T5-28	BT05028	28	43,75	160	160	T10-32	BT10032	32	100,00	160	160
T2,5-34	BT25034	34	26,55	125	140	T5-29	BT05029	29	45,35	160	160	T10-34	BT10034	34	106,40	160	160
T2,5-35	BT25035	35	27,35	132	140	T5-30	BT05030	30	46,95	160	160	T10-36	BT10036	36	112,75	160	160
T2,5-36	BT25036	36	28,10	132	140	T5-32	BT05032	32	50,10	160	160	T10-38	BT10038	38	119,10	160	160
T2,5-38	BT25038	38	29,70	132	140	T5-34	BT05034	34	53,25	160	160	T10-40	BT10040	40	125,45	160	160
T2,5-40	BT25040	40	31,30	132	140	T5-35	BT05035	35	54,85	160	160	T10-45	BT10045	45	141,40	160	160
T2,5-42	BT25042	42	32,90	140	140	T5-36	BT05036	36	56,45	160	160	T10-48	BT10048	48	150,95	160	160
T2,5-44	BT25044	44	34,50	140	140	T5-37	BT05037	37	58,06	160	160	T10-60	BT10060	60	189,10	160	160
T2,5-45	BT25045	45	35,30	140	140	T5-38	BT05038	38	59,65	160	160	T10-72	BT10072	72	227,29	160	160
T2,5-48	BT25048	48	37,70	140	140	T5-40	BT05040	40	62,85	160	160						
T2,5-50	BT25050	50	39,29	160	160	T5-42	BT05042	42	66,00	160	160						
T2,5-60	BT25060	60	47,25	160	160	T5-44	BT05044	44	69,20	160	160						
T2,5-65	BT25065	65	51,20	160	160	T5-45	BT05045	45	70,80	160	160						
T2,5-70	BT25070	70	55,20	160	160	T5-46	BT05046	46	72,40	160	160						
T2,5-72	BT25072	72	56,80	160	160	T5-48	BT05048	48	75,55	160	160						
T2,5-90	BT25090	90	71,12	160	160	T5-50	BT05050	50	78,75	160	160						
T2,5-100	BT25100	100	79,08	160	160	T5-60	BT05060	60	94,65	160	160						
						T5-72	BT05072	72	113,75	160	160						
						T5-80	BT05080	80	126,48	160	160						
						T5-90	BT05090	90	142,40	160	160						
						T5-100	BT05100	100	158,31	160	160						

PER BARRE CON N. DI DENTI NON INCLUSI IN QUESTE TAVOLE, CHIEDERE PER QUOTAZIONE
 FOR BARS WITH A NUMBER OF TEETH NOT INCLUDED IN THESE TABLES PLEASE ASK FOR OUR QUOTATION
 VERLANGEN SIE ANGEBOET FUER STANGEN MIT ANZAHL VON ZAEHNEN DIE NICHT IN DIESEN TAFELN AUFGEFUEHRT SIND
 POUR LES BARREAUX AVEC UN NOMBRE DE DENTS DIFFERENT DU TABLEAU, NOUS CONSULTER
 PIDAN OFERTA POR LO QUE CONCIERNE UNA CANDIDAD DE DIENTES NO INCLUIDA EN ESTAS TABLAS



N. DENTI N. OF TEETH ZÄHNEZAHL NOMBRE DE DENTS CANTIDAD DE DIENTES	FLANGIA - FLANGES - BORDSCHEIBEN - FLASQUES - TAPETAS				TIPO FLANGIA FLANGES TYPE BORDSCHEIBEN TYP TYPE FLASQUES TIPO TAPETAS			
	d = 0,5 mm	d = 1 mm	d = 1 mm	d = 1,5 mm				
	T 2,5	T 5	T 10	T 20				
8	-	-	-	-	F 01	13	10	6
9	-	-	-	-	F 02	15	12	8
10	-	F 06	-	-	F 03	16	13	9,5
11	-	-	-	-	F 04	17,5	14,5	11,6
12	F 01	F 07	F 15	-	F 05	18	15	11,5
13	-	-	-	-	F 06	20	16,5	12,2
14	F 02	F 08	F 18	-	F 07	23	18	12,5
15	F 02	F 09	F 19	-	F 08	25	21,5	15
16	F 03	F 10	F 20	-	F 09	28	24	17,8
17	-	-	-	-	F 10	32	27,5	23
18	F 04	F 10	F 22	F 38	F 11	35	30,5	23
19	F 05	F 12	F 25	-	F 12	36	31	25
20	F 06	F 12	F 25	F 43	F 13	37	33	25
21	-	-	-	-	F 14	38	34	26,5
22	F 07	F 14	F 27	F 46	F 15	42	38	30,5
23	-	-	-	-	F 16	43	39	31
24	F 07	F 15	F 29	F 50	F 17	44	40,5	32,5
25	F 07	F 17	F 29	F 52	F 18	48	43,5	37
26	F 08	F 17	F 30	-	F 19	51	47	40
27	-	F 18	F 31	-	F 20	54	50,5	43
28	F 08	F 18	F 32	-	F 21	57	52	46
29	-	-	-	-	F 22	60	57	47
30	F 09	F 19	F 33	F 59	F 23	61	56,5	49
31	-	-	-	-	F 24	64	57	47
32	F 10	F 20	F 35	-	F 25	66	63	52
33	-	-	-	-	F 26	70	66,5	53
34	-	-	-	-	F 27	75	68,5	60
35	-	-	-	-	F 28	79	72,5	60
36	F 12	F 24	F 38	-	F 29	83	78	68
37	-	-	-	-	F 30	87	82,5	72
38	-	-	-	-	F 31	91	85,5	76
39	-	-	-	-	F 32	93	89	80
40	F 14	F 25	F 41	-	F 33	97	93,8	83
41	-	-	-	-	F 34	102	97	82,5
42	-	F 26	-	-	F 35	106	101	90
43	-	-	-	-	F 36	112	105,5	91
44	F 15	-	-	-	F 37	115	109	94
45	-	-	-	-	F 38	120	112,5	99,5
46	-	-	-	-	F 39	123	117,5	107
47	-	-	-	-	F 40	128	124	107
48	-	-	-	-	F 41	131	125,5	115
49	-	-	-	-	F 42	135	128,5	115
50	-	-	-	-	F 43	138	132	121
51	-	-	-	-	F 44	140	125	107
52	-	-	-	-	F 45	142	137	120
53	-	-	-	-	F 46	146	133	107
54	-	-	-	-	F 47	148	143	132
55	-	-	-	-	F 48	150	145	130
56	-	-	-	-	F 49	154	142	122
57	-	-	-	-	F 50	158	153	138,5
58	-	-	-	-	F 51	160	148	120
59	-	-	-	-	F 52	168	161	148
60	-	-	-	-	F 53	175	170	157
61	-	-	-	-	F 54	180	174	154
62	-	-	-	-	F 55	184	168	135
63	-	-	-	-	F 56	188	176	150
64	-	-	-	-	F 57	192	187	173
65	-	-	-	-	F 58	198	180	150
66	-	-	-	-	F 59	200	193	180
					F 60	205	189	160
					F 61	212	200	162
					F 62	226	214	190
					F 63	230	222	200
					F 64	240	224	192
					F 65	250	228	200
					F 66	256	240	220
					F 67	265	240	213
					F 68	275	253	225
					F 69	286	277	242
					F 70	296	287	260
					F 71	300	280	252
					F 72	325	305	278
					F 73	350	330	302
					F 74	375	355	328
					F 75	405	380	354
					F 76	430	406	380
					F 77	455	432	405
					F 78	480	457	430
					F 79	530	508	481
					F 80	595	572	544

**Pulegge per cinghie dentate
passo metrico ST per cinghie «AT»
ST Timing belt pulleys metric pitch for «AT» belts
ST Zahnriemenscheiben metrische Teilung für «AT»
Poulies dentées ST
pour courroies «AT» pas métrique
Poleas dentadas ST para correas «AT» paso en mm**

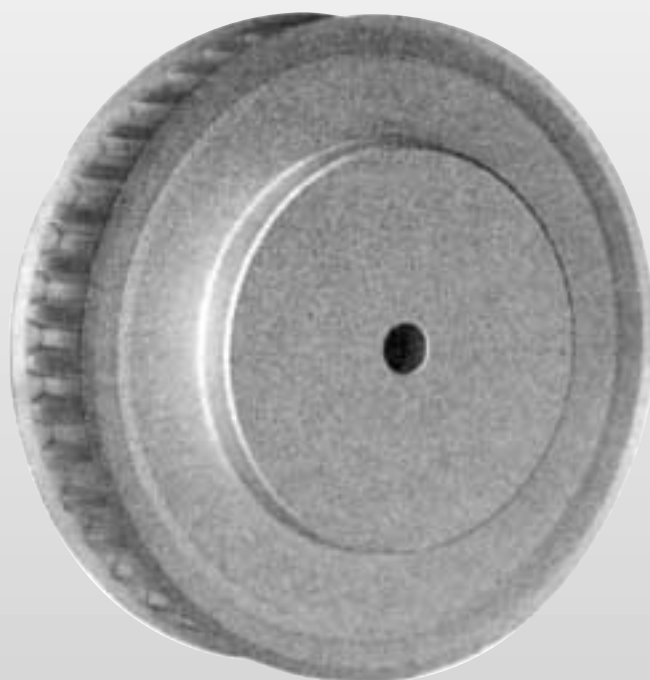

Pulegge per cinghie dentate passo metrico ST per cinghie " AT "
ST Timing belt pulleys metric pitch for " AT " belts
ST Zahnriemenscheiben metrische Teilung für " AT "
Poules dentées ST pour courroies " AT " pas métrique
Poleas dentadas ST para correas " AT " paso en mm

Materiale: alluminio 6082 T6 UNI 9006/4 adatto al trattamento anodico

Material: aluminium 6082 T6 UNI 9006/4 suitable for anodic treatment

Material: aluminium 6082 T6 UNI 9006/4 geeignet für anodischen oxydation

Material: aluminium 6082 T6 UNI 9006/4 apte au traitement anodique

Material: aluminio 6082 T6 UNI 9006/4 apto para la oxidacion anodica

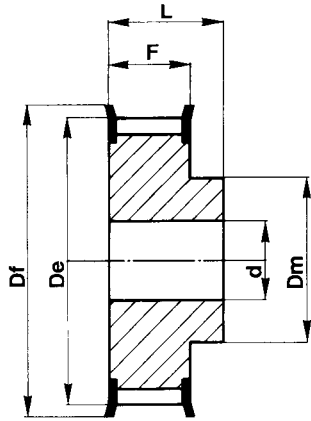

TIPO 6F
TYPE 6F

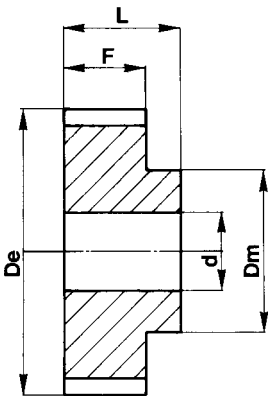

TIPO 6
TYPE 6

(PASSO 5 mm) PER CINGHIA LARGHEZZA 10 mm - (PITCH 5 mm) FOR BELT WIDTH 10 mm
 (TEILUNG 5 mm) FUER RIEMENBREITE 10 mm - (PAS 5 mm) POUR COURROIES LARGEUR 10 mm
 (PASO 5 mm) PARA CORREAS ANCHO 10 mm

ST 5

CODICE CODE SYMBOL FABRIKNUMMER CODE SYMBOLE NUMERO DE FABRICA	NOSTRO CODICE OUR CODE UNSER KODE NOTRE CODE NUESTRO CODIGO	TIPO TYPE TYP TYPE TIPO	TIPO FLANGIA FLANGES TYPE BORDSCHEIBEN TYP TYPE FLASQUES TIPO TAPETAS	N.DENTI N. OF TEETH ZAHNEZAHL N. BRE DE DENTS CANTIDAD DE DIENTES	De	Df	Dm	F	L	d	PESO WEIGHT GEWICHT POIDS PESO Kg
21 ST5/12-2	21ST512	6F	F07	12	17,85	23,0	11	15	21	4	0,018
21 ST5/14-2	21ST514	6F	F08	14	21,05	25,0	14	15	21	4	0,019
21 ST5/15-2	21ST515	6F	F09	15	22,65	28,0	16	15	21	6	0,021
21 ST5/16-2	21ST516	6F	F10	16	24,20	32,0	18	15	21	6	0,025
21 ST5/18-2	21ST518	6F	F10	18	27,40	32,0	20	15	21	6	0,031
21 ST5/19-2	21ST519	6F	F12	19	29,00	36,0	22	15	21	6	0,036
21 ST5/20-2	21ST520	6F	F12	20	30,60	36,0	23	15	21	6	0,038
21 ST5/22-2	21ST522	6F	F14	22	33,85	38,0	24	15	21	6	0,048
21 ST5/24-2	21ST524	6F	F15	24	37,00	42,0	26	15	21	6	0,054
21 ST5/25-2	21ST525	6F	F17	25	38,60	44,0	26	15	21	6	0,058
21 ST5/26-2	21ST526	6F	F17	26	40,20	44,0	26	15	21	6	0,062
21 ST5/27-2	21ST527	6F	F18	27	41,80	48,0	30	15	21	8	0,064
21 ST5/28-2	21ST528	6F	F18	28	43,35	48,0	32	15	21	8	0,071
21 ST5/30-2	21ST530	6F	F19	30	46,55	51,0	34	15	21	8	0,076
21 ST5/32-2	21ST532	6F	F20	32	49,70	54,0	36	15	21	8	0,088
21 ST5/36-2	21ST536	6F	F24	36	56,05	64,0	38	15	21	8	0,114
21 ST5/40-2	21ST540	6F	F25	40	62,45	66,0	40	15	21	8	0,138
21 ST5/42-2	21ST542	6F	F26	42	65,60	70,0	40	15	21	8	0,180
21 ST5/44-0	21ST544	6		44	68,80	-	45	15	21	8	0,185
21 ST5/48-0	21ST548	6		48	75,15	-	50	15	21	8	0,200
21 ST5/60-0	21ST560	6		60	94,25	-	65	15	21	8	0,307

(PASSO 5 mm) PER CINGHIA LARGHEZZA 16 mm - (PITCH 5 mm) FOR BELT WIDTH 16 mm
 (TEILUNG 5 mm) FUER RIEMENBREITE 16 mm - (PAS 5 mm) POUR COURROIES LARGEUR 16 mm
 (PASO 5 mm) PARA CORREAS ANCHO 16 mm

ST 5

CODICE CODE SYMBOL FABRIKNUMMER CODE SYMBOLE NUMERO DE FABRICA	NOSTRO CODICE OUR CODE UNSER KODE NOTRE CODE NUESTRO CODIGO	TIPO TYPE TYP TYPE TIPO	TIPO FLANGIA FLANGES TYPE BORDSCHEIBEN TYP TYPE FLASQUES TIPO TAPETAS	N.DENTI N. OF TEETH ZAHNEZAHL N. BRE DE DENTS CANTIDAD DE DIENTES	De	Df	Dm	F	L	d	PESO WEIGHT GEWICHT POIDS PESO Kg
27 ST5/12-2	27ST512	6F	F07	12	17,85	23,0	11	21	27	4	0,022
27 ST5/14-2	27ST514	6F	F08	14	21,05	25,0	14	21	27	4	0,026
27 ST5/15-2	27ST515	6F	F09	15	22,65	28,0	16	21	27	6	0,029
27 ST5/16-2	27ST516	6F	F10	16	24,20	32,0	18	21	27	6	0,035
27 ST5/18-2	27ST518	6F	F10	18	27,40	32,0	20	21	27	6	0,043
27 ST5/19-2	27ST519	6F	F12	19	29,00	36,0	22	21	27	6	0,049
27 ST5/20-2	27ST520	6F	F12	20	30,60	36,0	23	21	27	6	0,053
27 ST5/22-2	27ST522	6F	F14	22	33,85	38,0	24	21	27	6	0,054
27 ST5/24-2	27ST524	6F	F15	24	37,00	42,0	26	21	27	6	0,076
27 ST5/25-2	27ST525	6F	F17	25	38,60	44,0	26	21	27	6	0,081
27 ST5/26-2	27ST526	6F	F17	26	40,20	44,0	26	21	27	6	0,085
27 ST5/27-2	27ST527	6F	F18	27	41,80	48,0	30	21	27	8	0,090
27 ST5/28-2	27ST528	6F	F18	28	43,35	48,0	32	21	27	8	0,092
27 ST5/30-2	27ST530	6F	F19	30	46,55	51,0	34	21	27	8	0,105
27 ST5/32-2	27ST532	6F	F20	32	49,70	54,0	36	21	27	8	0,123
27 ST5/36-2	27ST536	6F	F24	36	56,05	64,0	38	21	27	8	0,160
27 ST5/40-2	27ST540	6F	F25	40	62,45	66,0	40	21	27	8	0,193
27 ST5/42-2	27ST542	6F	F26	42	65,60	70,0	40	21	27	8	0,205
27 ST5/44-0	27ST544	6		44	68,80	-	45	21	27	8	0,228
27 ST5/48-0	27ST548	6		48	75,15	-	50	21	27	8	0,280
27 ST5/60-0	27ST560	6		60	94,25	-	65	21	27	8	0,430

(PASSO 5 mm) PER CINGHIA LARGHEZZA 25 mm - (PITCH 5 mm) FOR BELT WIDTH 25 mm
 (TEILUNG 5 mm) FUER RIEMENBREITE 25 mm - (PAS 5 mm) POUR COURROIES LARGEUR 25 mm
 (PASO 5 mm) PARA CORREAS ANCHO 25 mm

ST 5

CODICE CODE SYMBOL FABRIKNUMMER CODE SYMBOLE NUMERO DE FABRICA	NOSTRO CODICE OUR CODE UNSER KODE NOTRE CODE NUESTRO CODIGO	TIPO TYPE TYP TYPE TIPO	TIPO FLANGIA FLANGES TYPE BORDSCHEIBEN TYP TYPE FLASQUES TIPO TAPETAS	N.DENTI N. OF TEETH ZAHNEZAHL N. BRE DE DENTS CANTIDAD DE DIENTES	De	Df	Dm	F	L	d	PESO WEIGHT GEWICHT POIDS PESO Kg
36 ST5/12-2	36ST512	6F	F07	12	17,85	23,0	11	30	36	4	0,031
36 ST5/14-2	36ST514	6F	F08	14	21,05	25,0	14	30	36	4	0,037
36 ST5/15-2	36ST515	6F	F09	15	22,65	28,0	16	30	36	6	0,041
36 ST5/16-2	36ST516	6F	F10	16	24,20	32,0	18	30	36	6	0,050
36 ST5/18-2	36ST518	6F	F10	18	27,40	32,0	20	30	36	6	0,061
36 ST5/19-2	36ST519	6F	F12	19	29,00	36,0	22	30	36	6	0,070
36 ST5/20-2	36ST520	6F	F12	20	30,60	36,0	23	30	36	6	0,076
36 ST5/22-2	36ST522	6F	F14	22	33,85	38,0	24	30	36	6	0,080
36 ST5/24-2	36ST524	6F	F15	24	37,00	42,0	26	30	36	6	0,109
36 ST5/25-2	36ST525	6F	F17	25	38,60	44,0	26	30	36	6	0,118
36 ST5/26-2	36ST526	6F	F17	26	40,20	44,0	26	30	36	6	0,120
36 ST5/27-2	36ST527	6F	F18	27	41,80	48,0	30	30	36	8	0,128
36 ST5/28-2	36ST528	6F	F18	28	43,35	48,0	32	30	36	8	0,135
36 ST5/30-2	36ST530	6F	F19	30	46,55	51,0	34	30	36	8	0,150
36 ST5/32-2	36ST532	6F	F20	32	49,70	54,0	36	30	36	8	0,178
36 ST5/36-2	36ST536	6F	F24	36	56,05	64,0	38	30	36	8	0,230
36 ST5/40-2	36ST540	6F	F25	40	62,45	66,0	40	30	36	8	0,278
36 ST5/42-2	36ST542	6F	F26	42	65,60	70,0	40	30	36	8	0,284
36 ST5/44-0	36ST544	6		44	68,80	-	45	30	36	8	0,315
36 ST5/48-0	36ST548	6		48	75,15	-	50	30	36	8	0,400
36 ST5/60-0	36ST560	6		60	94,25	-	65	30	36	8	0,614

Pulegge per cinghie dentate passo metrico ST per cinghie " AT "
ST Timing belt pulleys metric pitch for " AT " belts
ST Zahnriemenscheiben metrische Teilung für " AT "
Poulies dentées ST pour courroies " AT " pas métrique
Poleas dentadas ST para correas " AT " paso en mm



Materiale: alluminio 6082 T6 UNI 9006/4 adatto al trattamento anodico

Material: aluminium 6082 T6 UNI 9006/4 suitable for anodic treatment

Material: aluminium 6082 T6 UNI 9006/4 geeignet für anodischen oxydation

Material: aluminium 6082 T6 UNI 9006/4 apte au traitement anodique

Material: aluminio 6082 T6 UNI 9006/4 apto para la oxidacion anodica

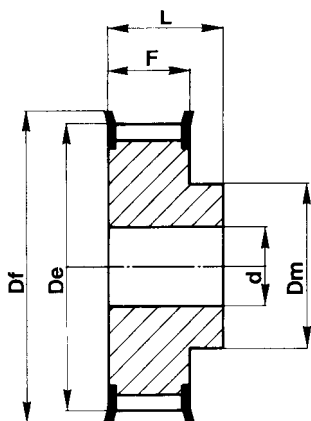

TIPO TYPE 6F

(PASSO 5 mm) PER CINGHIA LARGHEZZA 16 mm - (PITCH 5 mm) FOR BELT WIDTH 16 mm
 (TEILUNG 5 mm) FUER RIEMENBREITE 16 mm - (PAS 5 mm) POUR COURROIES LARGEUR 16 mm
 (PASO 5 mm) PARA CORREAS ANCHO 16 mm

ST 10

CODICE CODE SYMBOL FABRIKNUMMER CODE SYMBOLE NUMERO DE FABRICA	NOSTRO CODICE OUR CODE UNSER KODE NOTRE CODE NUESTRO CODIGO	TIPO TYPE TYP TYPE TIPO	TIPO FLANGIA FLANGES TYPE BORDSCHEIBEN TYP TYPE FLASQUES TIPO TAPETAS	N.DENTI N. OF TEETH ZAHNEZAHL N. BRE DE DENTS CANTIDAD DE DIENTES	De	Df	Dm	F	L	d	PESO WEIGHT GEWICHT POIDS PESO Kg
31 ST10/15-2	31ST115	6F	F19	15	45,90	51	31	21	31	8	0,118
31 ST10/16-2	31ST116	6F	F20	16	49,05	54	35	21	31	8	0,134
31 ST10/18-2	31ST118	6F	F22	18	55,45	60	40	21	31	8	0,167
31 ST10/19-2	31ST119	6F	F25	19	58,60	66	44	21	31	8	0,184
31 ST10/20-2	31ST120	6F	F25	20	61,80	66	46	21	31	8	0,208
31 ST10/22-2	31ST122	6F	F27	22	68,15	75	52	21	31	8	0,253
31 ST10/24-2	31ST124	6F	F29	24	74,55	83	58	21	31	8	0,288
31 ST10/25-2	31ST125	6F	F29	25	77,70	83	60	21	31	8	0,310
31 ST10/26-2	31ST126	6F	F30	26	80,90	87	60	21	31	8	0,357
31 ST10/27-2	31ST127	6F	F31	27	84,10	91	60	21	31	8	0,364
31 ST10/28-2	31ST128	6F	F32	28	87,25	93	60	21	31	8	0,401
31 ST10/30-2	31ST130	6F	F33	30	93,65	97	60	21	31	8	0,441
31 ST10/32-2	31ST132	6F	F35	32	100,00	106	65	21	31	10	0,493
31 ST10/36-2	31ST136	6F	F38	36	112,75	120	70	21	31	10	0,623
31 ST10/40-2	31ST140	6F	F42	40	125,45	135	80	21	31	10	0,787
31 ST10/44-0	31ST144	6		44	138,20	-	88	21	31	10	0,993
31 ST10/48-0	31ST148	6		48	150,95	-	95	21	31	16	1,090
31 ST10/60-0	31ST160	6		60	189,10	-	110	21	31	16	1,701

(PASSO 5 mm) PER CINGHIA LARGHEZZA 25 mm - (PITCH 5 mm) FOR BELT WIDTH 25 mm
 (TEILUNG 5 mm) FUER RIEMENBREITE 25 mm - (PAS 5 mm) POUR COURROIES LARGEUR 25 mm
 (PASO 5 mm) PARA CORREAS ANCHO 25 mm

ST 10

CODICE CODE SYMBOL FABRIKNUMMER CODE SYMBOLE NUMERO DE FABRICA	NOSTRO CODICE OUR CODE UNSER KODE NOTRE CODE NUESTRO CODIGO	TIPO TYPE TYP TYPE TIPO	TIPO FLANGIA FLANGES TYPE BORDSCHEIBEN TYP TYPE FLASQUES TIPO TAPETAS	N.DENTI N. OF TEETH ZAHNEZAHL N. BRE DE DENTS CANTIDAD DE DIENTES	De	Df	Dm	F	L	d	PESO WEIGHT GEWICHT POIDS PESO Kg
40 ST10/15-2	40ST115	6F	F19	15	45,90	51	32	30	40	8	0,152
40 ST10/16-2	40ST116	6F	F20	16	49,05	54	35	30	40	8	0,176
40 ST10/18-2	40ST118	6F	F22	18	55,45	60	40	30	40	8	0,224
40 ST10/19-2	40ST119	6F	F25	19	58,60	66	44	30	40	8	0,247
40 ST10/20-2	40ST120	6F	F25	20	61,80	66	46	30	40	8	0,276
40 ST10/22-2	40ST122	6F	F27	22	68,15	75	52	30	40	8	0,337
40 ST10/24-2	40ST124	6F	F29	24	74,55	83	58	30	40	8	0,392
40 ST10/25-2	40ST125	6F	F29	25	77,70	83	60	30	40	8	0,422
40 ST10/26-2	40ST126	6F	F30	26	80,90	87	60	30	40	8	0,477
40 ST10/27-2	40ST127	6F	F31	27	84,10	91	60	30	40	8	0,536
40 ST10/28-2	40ST128	6F	F32	28	87,25	93	60	30	40	8	0,540
40 ST10/30-2	40ST130	6F	F33	30	93,65	97	60	30	40	8	0,640
40 ST10/32-2	40ST132	6F	F35	32	100,00	106	65	30	40	10	0,693
40 ST10/36-2	40ST136	6F	F38	36	112,75	120	70	30	40	10	0,873
40 ST10/40-2	40ST140	6F	F42	40	125,45	135	80	30	40	10	1,067
40 ST10/44-0	40ST144	6		44	138,20	-	88	30	40	10	1,350
40 ST10/48-0	40ST148	6		48	150,95	-	95	30	40	16	1,516
40 ST10/60-0	40ST160	6		60	189,10	-	110	30	40	16	2,339

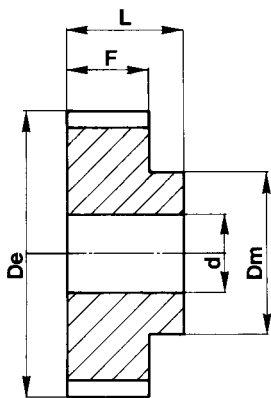

TIPO TYPE 6

Pulegge per cinghie dentate passo metrico ST per cinghie " AT "
ST Timing belt pulleys metric pitch for " AT " belts
ST Zahnriemenscheiben metrische Teilung für " AT "
Poulies dentées ST pour courroies " AT " pas métrique
Poleas dentadas ST para correas " AT " paso en mm

Materiale: alluminio 6082 T6 UNI 9006/4 adatto al trattamento anodico

Material: aluminium 6082 T6 UNI 9006/4 suitable for anodic treatment

Material: aluminium 6082 T6 UNI 9006/4 geeignet für anodischen oxydation

Material: aluminium 6082 T6 UNI 9006/4 apte au traitement anodique

Material: aluminio 6082 T6 UNI 9006/4 apto para la oxidacion anodica

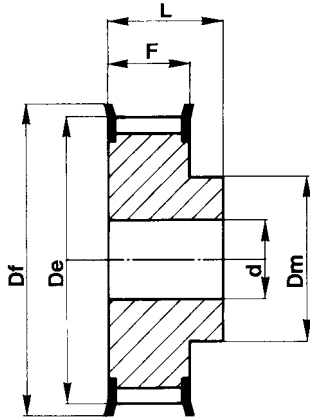

TIPO 6F
TYPE 6F

ST 10 (PASSO 10 mm) PER CINGHIA LARGHEZZA 32 mm - (PITCH 10 mm) FOR BELT WIDTH 32 mm
 (TEILUNG 10 mm) FUER RIEMENBREITE 32 mm - (PAS 10 mm) POUR COURROIES LARGEUR 32 mm
 (PASO 10 mm) PARA CORREAS ANCHO 32 mm

CODICE CODE SYMBOL FABRIKNUMMER CODE SYMBOLE NUMERO DE FABRICA	NOSTRO CODICE OUR CODE UNSER KODE NOTRE CODE NUESTRO CODIGO	TIPO TYPE TYP TYPE TIPO	TIPO FLANGIA FLANGES TYPE BORDSCEIBEN TYP TYPE FLASQUES TIPO TAPETAS	N.DENTI N. OF TEETH ZAHNEZAHL N. BRE DE DENTS CANTIDAD DE DIENTES	De	Df	Dm	F	L	d	PESO WEIGHT GEWICHT POIDS PESO Kg
47 ST10/18-2	47ST118	6F	F22	18	55,45	60	40	37	47	10	0,253
47 ST10/19-2	47ST119	6F	F25	19	58,60	66	44	37	47	10	0,286
47 ST10/20-2	47ST120	6F	F25	20	61,80	66	46	37	47	12	0,322
47 ST10/22-2	47ST122	6F	F27	22	68,15	75	52	37	47	12	0,393
47 ST10/24-2	47ST124	6F	F29	24	74,55	83	58	37	47	12	0,475
47 ST10/25-2	47ST125	6F	F29	25	77,70	83	60	37	47	12	0,527
47 ST10/26-2	47ST126	6F	F30	26	80,90	87	60	37	47	12	0,564
47 ST10/27-2	47ST127	6F	F31	27	84,10	91	60	37	47	12	0,602
47 ST10/28-2	47ST128	6F	F32	28	87,25	93	60	37	47	12	0,642
47 ST10/30-2	47ST130	6F	F33	30	93,65	97	60	37	47	12	0,740
47 ST10/32-2	47ST132	6F	F35	32	100,00	106	65	37	47	12	0,844
47 ST10/36-2	47ST136	6F	F38	36	112,75	120	70	37	47	16	1,063
47 ST10/40-2	47ST140	6F	F42	40	125,45	135	80	37	47	16	1,317
47 ST10/44-0	47ST144	6		44	138,20	-	88	37	47	16	1,611
47 ST10/48-0	47ST148	6		48	150,95	-	95	37	47	16	1,931
47 ST10/60-0	47ST160	6		60	189,10	-	110	37	47	16	3,004

ST 10 (PASSO 10 mm) PER CINGHIA LARGHEZZA 50 mm - (PITCH 10 mm) FOR BELT WIDTH 50 mm
 (TEILUNG 10 mm) FUER RIEMENBREITE 50 mm - (PAS 10 mm) POUR COURROIES LARGEUR 50 mm
 (PASO 10 mm) PARA CORREAS ANCHO 50 mm

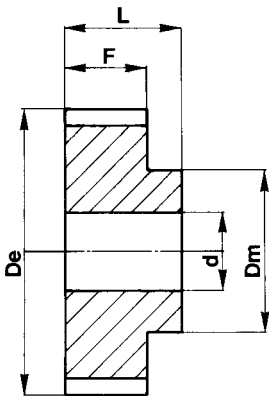

TIPO 6
TYPE 6

CODICE CODE SYMBOL FABRIKNUMMER CODE SYMBOLE NUMERO DE FABRICA	NOSTRO CODICE OUR CODE UNSER KODE NOTRE CODE NUESTRO CODIGO	TIPO TYPE TYP TYPE TIPO	TIPO FLANGIA FLANGES TYPE BORDSCEIBEN TYP TYPE FLASQUES TIPO TAPETAS	N.DENTI N. OF TEETH ZAHNEZAHL N. BRE DE DENTS CANTIDAD DE DIENTES	De	Df	Dm	F	L	d	PESO WEIGHT GEWICHT POIDS PESO Kg
66 ST10/18-2	66ST118	6F	F22	18	55,45	60	40	56	66	10	0,422
66 ST10/19-2	66ST119	6F	F25	19	58,60	66	44	56	66	10	0,466
66 ST10/20-2	66ST120	6F	F25	20	61,80	66	46	56	66	12	0,520
66 ST10/22-2	66ST122	6F	F27	22	68,15	75	52	56	66	12	0,570
66 ST10/24-2	66ST124	6F	F29	24	74,55	83	58	56	66	12	0,736
66 ST10/25-2	66ST125	6F	F29	25	77,70	83	60	56	66	12	0,766
66 ST10/26-2	66ST126	6F	F30	26	80,90	87	60	56	66	12	0,816
66 ST10/27-2	66ST127	6F	F31	27	84,10	91	60	56	66	12	0,946
66 ST10/28-2	66ST128	6F	F32	28	87,25	93	60	56	66	12	0,960
66 ST10/30-2	66ST130	6F	F33	30	93,65	97	60	56	66	12	1,169
66 ST10/32-2	66ST132	6F	F35	32	100,00	106	65	56	66	12	1,300
66 ST10/36-2	66ST136	6F	F38	36	112,75	120	70	56	66	16	1,637
66 ST10/40-2	66ST140	6F	F42	40	125,45	135	80	56	66	16	1,999
66 ST10/44-0	66ST144	6		44	138,20	-	88	56	66	16	2,357
66 ST10/48-0	66ST148	6		48	150,95	-	95	56	66	16	2,830
66 ST10/60-0	66ST160	6		60	189,10	-	110	56	66	16	4,368

Barre dentate standard ST per cinghie " AT "
ST Standard toothed bars for " AT " belts
ST Standard Zahnriemenstangen für " AT"
Barreaux dentés standard ST pour courroies " AT"
Barras dentadas de serie ST para correas " AT "

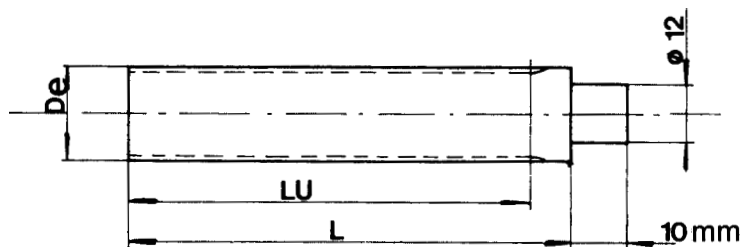

Materiale: alluminio 6082 T6 UNI 9006/4 adatto al trattamento anodico
Material: aluminium 6082 T6 UNI 9006/4 suitable for anodic treatment
Material: aluminium 6082 T6 UNI 9006/4 geeignet für anodischen oxydation
Material: alluminio 6082 T6 UNI 9006/4 apte au traitement anodique
Material: aluminio 6082 T6 UNI 9006/4 apto para la oxidacion anodica

ST 5
(PASSO 5 mm)
(PITCH 5 mm)
(TEILUNG 5 mm)
(PAS 5 mm)
(PASO 5 mm)

ST 10
(PASSO 5 mm)
(PITCH 5 mm)
(TEILUNG 5 mm)
(PAS 5 mm)
(PASO 5 mm)

CODICE CODE SYMBOL FABRIKNUMMER CODE SYMBOLE NUMERO DE FABRICA	NOSTRO CODICE OUR CODE UNSER KODE NOTRE CODE NUESTRO CODIGO	N.DENTI N. OF TEETH ZAHNEZAHL N. BRE DE DENTS CANTIDAD DE DIENTES	De	Lu	L
ST05012	BST0512	12	17,85	125	140
ST05013	BST0513	13	19,45	125	140
ST05014	BST0514	14	21,05	132	140
ST05015	BST0515	15	22,65	132	140
ST05016	BST0516	16	24,20	140	140
ST05017	BST0517	17	25,80	140	140
ST05018	BST0518	18	27,40	140	140
ST05019	BST0519	19	29,00	140	140
ST05020	BST0520	20	30,60	160	160
ST05021	BST0521	21	32,30	160	160
ST05022	BST0522	22	33,85	160	160
ST05023	BST0523	23	35,45	160	160
ST05024	BST0524	24	37,00	160	160
ST05025	BST0525	25	38,60	160	160
ST05026	BST0526	26	40,20	160	160
ST05027	BST0527	27	41,80	160	160
ST05028	BST0528	28	43,35	160	160
ST05029	BST0529	29	44,95	160	160
ST05030	BST0530	30	46,55	160	160
ST05031	BST0531	31	48,15	160	160
ST05032	BST0532	32	49,70	160	160
ST05033	BST0533	33	51,30	160	160
ST05034	BST0534	34	52,85	160	160
ST05035	BST0535	35	54,45	160	160
ST05036	BST0536	36	56,05	160	160
ST05038	BST0538	38	59,25	160	160
ST05040	BST0540	40	62,45	160	160
ST05042	BST0542	42	65,60	160	160
ST05044	BST0544	44	68,80	160	160
ST05045	BST0545	45	70,40	160	160
ST05046	BST0546	46	72,00	160	160
ST05048	BST0548	48	75,15	160	160
ST05050	BST0550	50	78,35	160	160
ST05052	BST0552	52	81,55	160	160
ST05054	BST0554	54	84,70	160	160
ST05055	BST0555	55	86,30	160	160
ST05056	BST0556	56	87,90	160	160
ST05058	BST0558	58	91,10	160	160
ST05060	BST0560	60	94,25	160	160
ST05062	BST0562	62	97,45	160	160
ST05064	BST0564	64	100,65	160	160
ST05065	BST0565	65	102,25	160	160
ST05070	BST0570	70	110,20	160	160
ST05072	BST0572	72	113,25	160	160

CODICE CODE SYMBOL FABRIKNUMMER CODE SYMBOLE NUMERO DE FABRICA	NOSTRO CODICE OUR CODE UNSER KODE NOTRE CODE NUESTRO CODIGO	N.DENTI N. OF TEETH ZAHNEZAHL N. BRE DE DENTS CANTIDAD DE DIENTES	De	Lu	L
ST10015	BST1015	15	45,90	160	160
ST10016	BST1016	16	49,05	160	160
ST10017	BST1017	17	52,25	160	160
ST10018	BST1018	18	55,45	160	160
ST10019	BST1019	19	58,60	160	160
ST10020	BST1020	20	61,80	160	160
ST10021	BST1021	21	65,00	160	160
ST10022	BST1022	22	68,15	160	160
ST10023	BST1023	23	71,35	160	160
ST10024	BST1024	24	74,55	160	160
ST10025	BST1025	25	77,70	160	160
ST10026	BST1026	26	80,90	160	160
ST10027	BST1027	27	84,10	160	160
ST10028	BST1028	28	87,25	160	160
ST10029	BST1029	29	90,45	160	160
ST10030	BST1030	30	93,65	160	160
ST10031	BST1031	31	96,80	160	160
ST10032	BST1032	32	100,00	160	160
ST10033	BST1033	33	103,20	160	160
ST10034	BST1034	34	106,40	160	160
ST10035	BST1035	35	109,55	160	160
ST10036	BST1036	36	112,75	160	160
ST10037	BST1037	37	115,90	160	160
ST10038	BST1038	38	119,10	160	160
ST10040	BST1040	40	125,45	160	160
ST10041	BST1041	41	128,65	160	160
ST10042	BST1042	42	131,85	160	160
ST10044	BST1044	44	138,20	160	160
ST10045	BST1045	45	141,40	160	160
ST10046	BST1046	46	144,55	160	160
ST10048	BST1048	48	150,95	160	160
ST10050	BST1050	50	157,30	160	160
ST10051	BST1051	51	160,50	160	160
ST10052	BST1052	52	163,65	160	160
ST10054	BST1054	54	170,05	160	160
ST10055	BST1055	55	173,20	160	160
ST10056	BST1056	56	176,40	160	160
ST10057	BST1057	57	179,60	160	160
ST10058	BST1058	58	182,75	160	160
ST10059	BST1059	59	185,95	160	160
ST10060	BST1060	60	189,10	160	160
ST10062	BST1062	62	195,50	160	160
ST10070	BST1070	70	220,95	160	160
ST10075	BST1075	75	236,90	160	160



N. DENTI N. OF TEETH ZÄHNEZAHL NOMBRE DE DENTS CANTIDAD DE DIENTES	FLANGIA - FLANGES - BORDSCHEIBEN - FLASQUES - TAPETAS		TIPO FLANGIA FLANGES TYPE BORDSCHEIBEN TYP TYPE FLASQUES TIPO TAPETAS			
	d = 1 mm	d = 1 mm				
	AT 5	AT 10				
8	-	-	F 01	13	10	6
9	-	-	F 02	15	12	8
10	-	-	F 03	16	13	9,5
11	-	-	F 04	17,5	14,5	11,6
12	F 07	-	F 05	18	15	11,5
13	-	-	F 06	20	16,5	12,2
14	F 08	-	F 07	23	18	12,5
15	F 09	F 19	F 08	25	21,5	15
16	F 10	F 20	F 09	28	24	17,8
17	-	-	F 10	32	27,5	23
18	F 10	F 22	F 11	35	30,5	23
19	F 12	F 25	F 12	36	31	25
20	F 12	F 25	F 13	37	33	25
21	-	-	F 14	38	34	26,5
22	F 14	F 27	F 15	42	38	30,5
23	-	-	F 16	43	39	31
24	F 15	F 29	F 17	44	40,5	32,5
25	F 17	F 29	F 18	48	43,5	37
26	F 17	F 30	F 19	51	47	40
27	F 18	F 31	F 20	54	50,5	43
28	F 18	F 32	F 21	57	52	46
29	-	-	F 22	60	57	47
30	F 19	F 33	F 23	61	56,5	49
31	-	-	F 24	64	57	47
32	F 20	F 35	F 25	66	63	52
33	-	-	F 26	70	66,5	53
34	-	-	F 27	75	68,5	60
35	-	-	F 28	79	72,5	60
36	F 24	F 38	F 29	83	78	68
37	-	-	F 30	87	82,5	72
38	-	-	F 31	91	85,5	76
39	-	-	F 32	93	89	80
40	F 25	F 42	F 33	97	93,8	83
41	-	-	F 34	102	97	82,5
42	F 26	-	F 35	106	101	90
43	-	-	F 36	112	105,5	91
44	-	-	F 37	115	109	94
45	-	-	F 38	120	112,5	99,5
46	-	-	F 39	123	117,5	107
47	-	-	F 40	128	124	107
48	-	-	F 41	131	125,5	115
49	-	-	F 42	135	128,5	115
50	-	-	F 43	138	132	121
51	-	-	F 44	140	125	107
52	-	-	F 45	142	137	120
53	-	-	F 46	146	133	107
54	-	-	F 47	148	143	132
55	-	-	F 48	150	145	130
56	-	-	F 49	154	142	122
57	-	-	F 50	158	153	138,5
58	-	-	F 51	160	148	120
59	-	-	F 52	168	161	148
60	-	-	F 53	175	170	157
61	-	-	F 54	180	174	154
62	-	-	F 55	184	168	135
63	-	-	F 56	188	176	150
64	-	-	F 57	192	187	173
65	-	-	F 58	198	180	150
66	-	-	F 59	200	193	180
			F 60	205	189	160
			F 61	212	200	162
			F 62	226	214	190
			F 63	230	222	200
			F 64	240	224	192
			F 65	250	228	200
			F 66	256	240	220
			F 67	265	240	213
			F 68	275	253	225
			F 69	286	277	242
			F 70	296	287	260
			F 71	300	280	252
			F 72	325	305	278
			F 73	350	330	302
			F 74	375	355	328
			F 75	405	380	354
			F 76	430	406	380
			F 77	455	432	405
			F 78	480	457	430
			F 79	530	508	481
			F 80	595	572	544