

TRASCO® ES: “0” Backlash Coupling



TRASCO® ES

TRASCO® ES: “0” backlash coupling

TRASCO® ES is our zero backlash coupling designed to compensate for misalignment and vibration dampening for

indexing applications. The compact design of TRASCO® ES makes it the right choice for all precise motion applications.

Description

The TRASCO® ES consists of two hubs, which are either made of high-strength aluminum (up to the 38/45 size) or steel (from size 42) that are connected with an elastic element.

The precise dimensional characteristics of TRASCO® ES are obtained through our accurate machining process.

The special compound polyurethane elastic element, developed through extensive research and laboratory testing, is made through a press-forming process which guarantees high dimensional accuracy.

The element is available in 4 different hardnesses: **80 Sh. A (blue)**, **92 Sh. A (yellow)**, **98 Sh. A (red)**, **64 Sh. D (green)**.

Coupling performance depends on the type of element selected (see “**Technical characteristics**”).

Other element hardnesses are available upon request to meet special operating conditions, such as high temperatures and/or high torques, and for providing a high degree of vibration dampening capability. Please contact our Engineering Office for help in selecting the appropriate element hardness.

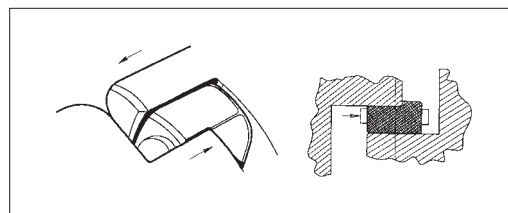
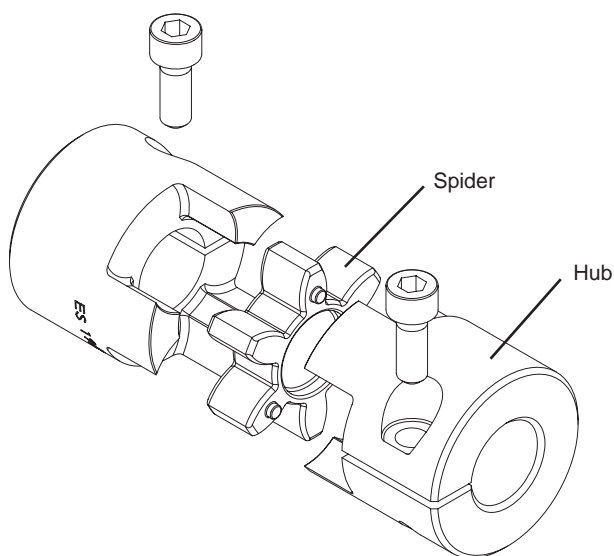

Operation

When the polyurethane element is installed in its special seats between the hubs, it becomes precompressed, thereby providing the zero backlash feature which characterizes the transmission performance of this coupling.

With zero backlash, the coupling remains torsionally rigid within the range of the precompression load, but does permit the

absorption of radial, angular, and axial misalignments as well as undesired vibrations.

The significantly wide precompressed area of the flexible element keeps the contact pressure against the elastic element low. Therefore, the element teeth can be overloaded many times without undergoing any wear or taking a permanent set.



Advantages

The TRASCO® ES coupling provides the following advantages:

- “zero-backlash” motion transmission
- dampening (up to 80%) of vibrations from motor shaft
- low heat and electrical conductivity
- easy and fast installation
- perfect balance (A & AP type)
- low moment of inertia (due to compact design and types of materials used).

Main applications

TRASCO® ES couplings are most frequently used with:

- servomotors
- robotics
- sliding tables
- spindle controls for drilling and grinding mandrels
- ball-bearing screws

Operating Temperature Range

The operating temperature range for the TRASCO® ES depends on the type of element. For the **92 Sh. A (yellow)**, the range is between **-40 and +90°C**, and for the **98 Sh.A (red)**, the range is between **-30 and +90°C**. Peak temperatures as high as 120°C can be tolerated for brief instances.

High operating temperatures can cause the elastic element to lose a considerable amount of elasticity, thus substantially lowering the torque handling capacity.

Therefore, when selecting a coupling, the operating temperature must be carefully considered (see “**Technical characteristics**”).

ATEX 94/9/EC compliance

It is possible to ask for specific certification for use in hazardous area according to EC standard **94/9/EC**. TRASCO® ES couplings are available with specific mounting/operating

instruction manual and conformity.

For information, please contact our technical office.

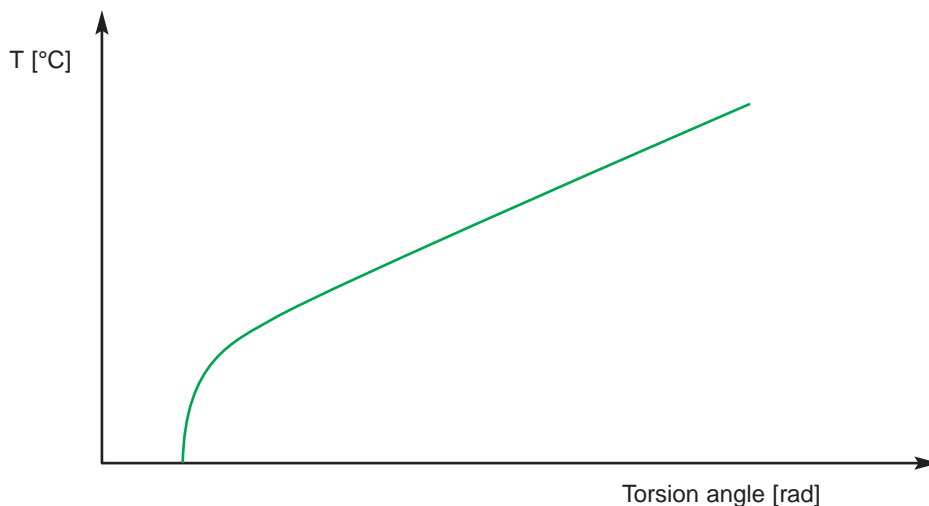

Technical characteristics

The following technical characteristics apply to all types of TRASCO® ES couplings.

When using the M, A and AP versions, check the torque values given in the table against the allowable hub transmission values for the respective versions given in the pertinent sections.

TRASCO® ES couplings can withstand axial, radial, and angular misalignment.

Even after operating for an extended period with a misalignment, there is still zero backlash because the elastic element is only stressed by pressure loads.

When an application causes a high degree of misalignment, a double flexing type coupling can be provided which avoids the formation of reaction forces.

Please contact our Engineering Office.

Size	Shore	T _{KN} [Nm]	T _{Kmax} [Nm]	C _T stat. [Nm/rad]	C _T din. [Nm/rad]	C _r [N/mm]	ΔK _a [mm]	ΔK _r [mm]	ΔK _w [°]
7	92 Sh.A (yellow)	1,2	2,4	14,3	43	219	0,6	0,1	1
	98 Sh.A (red)	2	4	22,9	69	421	0,6	0,06	0,9
	64 Sh.D (green)	2,4	4,8	34,8	103	630	0,6	0,04	0,8
9	92 Sh.A (yellow)	3	6	31,5	95	262	0,8	0,13	1
	98 Sh.A (red)	5	10	51,6	155	518	0,8	0,08	0,9
	64 Sh.D (green)	6	12	74,6	224	739	0,8	0,05	0,8
14	92 Sh.A (yellow)	7,5	15	114,6	344	336	1	0,15	1
	98 Sh.A (red)	12,5	25	171,9	513	604	1	0,09	0,9
	64 Sh.D (green)	16	32	234,2	702	856	1	0,06	0,8
19/24	80 Sh.A (blu)	5	10	370	1120	740	1,2	0,15	1,1
	92 Sh.A (yellow)	10	20	820	1920	1260	1,2	0,1	1
	98 Sh.A (red)	17	34	990	2350	2210	1,2	0,06	0,9
	64 Sh.D (green)	21	42	1470	4470	2970	1,2	0,04	0,8
24/28	80 Sh.A (blu)	17	34	860	1390	840	1,4	0,18	1,1
	92 Sh.A (yellow)	35	70	2300	5130	1900	1,4	0,14	1
	98 Sh.A (red)	60	120	3700	8130	2940	1,4	0,1	0,9
	64 Sh.D (green)	75	150	4500	11500	4200	1,4	0,07	0,8
28/38	80 Sh.A (blu)	46	92	1370	2350	990	1,5	0,2	1,3
	92 Sh.A (yellow)	95	190	3800	7270	2100	1,5	0,15	1
	98 Sh.A (red)	160	320	4200	10800	3680	1,5	0,11	0,9
	64 Sh.D (green)	200	400	7350	18400	4900	1,5	0,08	0,8
38/45	92 Sh.A (yellow)	190	380	5600	12000	2900	1,8	0,17	1
	98 Sh.A (red)	325	650	8140	21850	5040	1,8	0,12	0,9
	64 Sh.D (green)	405	810	9900	33500	6160	1,8	0,09	0,8
42	92 Sh.A (yellow)	265	530	9800	20500	4100	2	0,19	1
	98 Sh.A (red)	450	900	15180	34200	5940	2	0,14	0,9
	64 Sh.D (green)	560	1120	16500	71400	7590	2	0,1	0,8
48	92 Sh.A (yellow)	310	620	12000	22800	4500	2,1	0,23	1
	98 Sh.A (red)	525	1050	16600	49400	6820	2,1	0,16	0,9
	64 Sh.D (green)	655	1310	31350	102800	9000	2,1	0,11	0,8
55	92 Sh.A (yellow)	410	820	13000	23100	3200	2,2	0,24	1
	98 Sh.A (red)	685	1370	24000	63400	7100	2,2	0,17	0,9
	64 Sh.D (green)	825	1650	42160	111700	9910	2,2	0,12	0,8
65	92 Sh.A (yellow)	900	1800	38500	97200	6410	2,6	0,25	1
	98 Sh.A (red)	1040	2080	39800	99500	6620	2,6	0,18	0,9
75	98 Sh.A (red)	1920	3840	79150	150450	8650	3,0	0,21	0,9

All the technical data in the catalogue are valid for rotation speeds of 1500 rpm and a working temperature of 30 °C. For linear speed over 30 m/s, dynamic balancing is recommended.

Misalignments

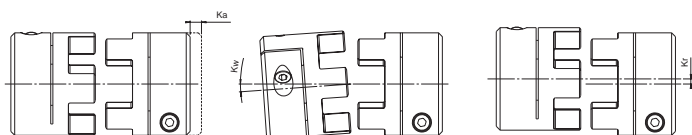

Assial

Angular

Radial

T _{KN}	Coupling nominal torque	Nm
T _{Kmax}	Coupling maximum torque	Nm
C _T	Torsional rigidity	Nm/rad
C _r	Radial stiffness	N/mm
ΔK _a	Maximum axial misalignment	mm
ΔK _r	Maximum radial misalignment	mm
ΔK _w	Maximum angular misalignment	°

Installation and maintenance

1. Carefully clean the shafts
2. Insert the hubs onto shafts being connected. With the M, A and AP versions, be sure to tighten the screws with the Ms torque value given in the catalogue. Be careful with the A and AP versions to tighten the screws uniformly and crosswise to the recommended torque
3. Position the element in one of the two coupling hubs
4. Fit together the two coupling halves, making sure the "s" dimension is properly observed. This must be done to insure proper elastic element function and long service life, as well as to assure the coupling is properly insulated electrically

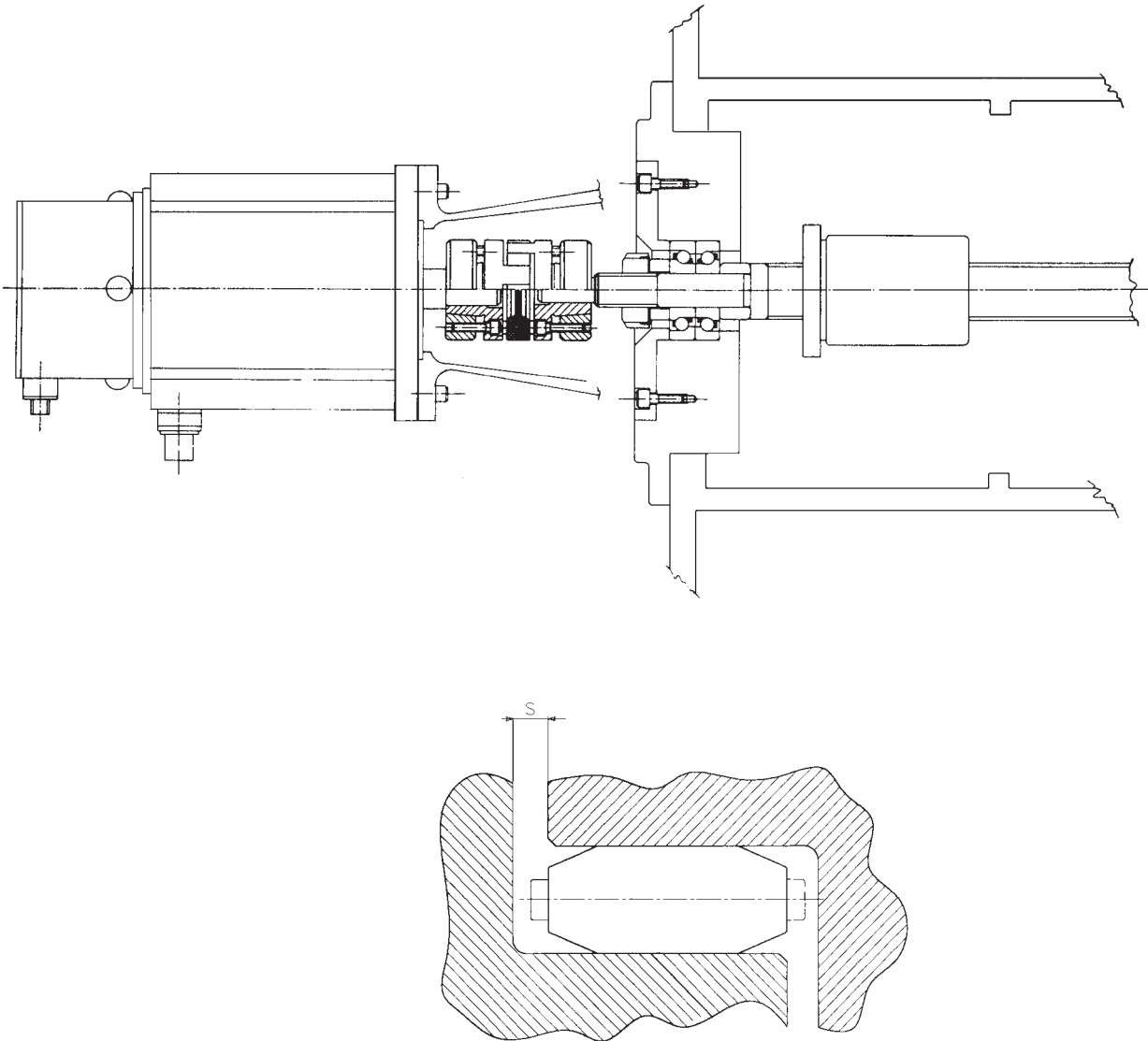

With the A and AP versions, mounting the hubs can be facilitated by lubricating the shaft contact surfaces with an oil, but **do not use a molybdenum bisulphide based oils**. When mounting the TRASCO® ES coupling an axial thrust is generated which disappears when the mounting has been com-

pleted to avoid putting axial loads on the bearings.

Lubrication of the elastic element will reduce the amount of axial force required during installation

Note: All rotating parts must be guarded.

Selection in according to DIN 740.2

The coupling must be chosen so the applied working loads do not exceed the allowable values whatever the working conditions are.

1. Check the load with respect to the nominal torque

The nominal coupling torque must be greater than or equal to the nominal torque of the drive machine for all working temperatures.

$$T_{KN} \geq T_K \cdot S_\theta \cdot S_D$$

2. Check the load with respect to the torque peak values

The maximum coupling torque must be greater than or equal to the torque peaks that occur during operation for all working temperatures.

$$T_{Kmax} \geq T_S \cdot S_Z \cdot S_\theta + T_K \cdot S_\theta \cdot S_D$$

Motor-side peaks: $T_S = T_{AS} \cdot \frac{1}{m+1} \cdot S_A + T_L^{(1)}$

Driven-side peaks: $T_S = T_{LS} \cdot \frac{m}{m+1} \cdot S_L + T_L^{(1)}$

3. Check the load with respect to periodic torque inversions

By means of resonance

When the resonance frequency is passed rapidly below the operational interval a few torque peaks will be seen. The generated alternating loads must be compared with the maximum torque the coupling can support.

$$T_{Kmax} \geq T_S \cdot S_Z \cdot S_\theta + T_K \cdot S_\theta \cdot S_D$$

Motor-side peaks: $T_S = T_{AI} \cdot \frac{1}{m+1} \cdot V_R + T_L^{(1)}$

Driven-side peaks: $T_S = T_{LI} \cdot \frac{m}{m+1} \cdot V_R + T_L^{(1)}$

4. Check the load with respect to nonperiodic torque inversions

To check the load with respect to nonperiodic torque inversions, the following equations must be satisfied:

$$0,25 T_{KN} = T_{KW} \geq T_W \cdot S_\theta \cdot S_f \cdot S_D$$

Motor-side peaks: $T_W = T_{AI} \cdot \frac{1}{m+1} \cdot V_{fi}$

Driven-side peaks: $T_W = T_{LI} \cdot \frac{m}{m+1} \cdot V_{fi}$

(1) T_L to be added if a torque peak occurs during acceleration.

Calculation coefficients

S_θ = Temperature factor

T [°C]	-30/+30	+40	+60	+80
S_θ	1	1,2	1,4	1,8

S_v = Starting frequency factor

S/h	0-100	101-200	201-400	401-800	801-1.600
S_Z	1	1,2	1,4	1,6	1,8

S_f = Frequency factor

f in Hz	≤10	>10
S_f	1	$\sqrt{f/10}$

S_D = Torsional rigidity factor

Tooling machines	Positioning system	Speed and angular acceleration indicator
2-5	3-8	10 ≥

S_L o S_A = Shock factor

Type of impact	S_L o S_a
Light	1,5
Medium	1,8
Strong	2,2

$$V_{fi} = \text{Torque-Amplification factor} = \sqrt{\frac{1 + \left(\frac{\Psi}{2\pi}\right)^2}{\left(1 - \frac{n^2}{n_R^2}\right)^2 + \left(\frac{\Psi}{2\pi}\right)^2}}$$

$$n_R = \text{Resonance frequency} = \frac{30}{\pi} \sqrt{C_{Tdin} \frac{J_A + J_L}{J_A \cdot J_L}} \quad [\text{min}^{-1}]$$

$$m = \text{Mass factor} = \frac{J_A}{J_L}$$

Example of selection

Application

Servomotor driving a recirculating ball screw on a machine tool

Nominal Torque	$T_K = 10,0 \text{ Nm}$	Shock Type	Light
Peak Torque	$T_{AS} = 22,0 \text{ Nm}$	Table Moment of Inertia	$J_3 = 0,0038 \text{ kg}\cdot\text{m}^2$
Rpm	$n = 3.000 \text{ 1/min}$	Driven Shaft	$d_c = 20 \text{ mm h6 (without keyway)}$
Moment of Inertia	$J_1 = 0,0058 \text{ kg}\cdot\text{m}^2$	Motor Shaft	$d_m = 24 \text{ mm h6 (without keyway)}$
Temperature	$T = +40^\circ\text{C}$		

Selection

24/28 "A" type ES coupling with "Red" elastic element (98 Sh. A)

Standard coupling torque:	$T_{KN} = 60 \text{ [Nm]}$
Maximum torque:	$T_{Kmax} = 120 \text{ [Nm]}$
Hub Moment of Inertia:	$J_2 = 0,000135 \text{ [kg}\cdot\text{m}^2]$
Couple Transmitted by taper locking ring:	$T_{cal} = \begin{cases} 92 \text{ [Nm] per foro 20 [mm]} \\ 113 \text{ [Nm] per foro 24 [mm]} \end{cases}$

Load check

$$T_{KN} = T_K \cdot S_\theta \cdot S_D = 10 \cdot 1,2 \cdot 4 = 48,0 \text{ [Nm]}$$

$$T_{KN} = 48,0 \text{ Nm} < T_{cal}$$

$$m = \frac{J_A}{J_L} \quad J_A = J_1 + J_2 \quad J_L = J_3 + J_2 \quad m = 1,5$$

$$T_S = T_{AS} \cdot \frac{1}{m+1} \cdot S_A = 22,0 \cdot \frac{1}{1,5+1} \cdot 1,5 = 13,2 \text{ [Nm]}$$

$$T_{Kmax} = T_S \cdot S_Z \cdot S_\theta + T_K \cdot S_\theta \cdot S_D = 13,2 \cdot 1,6 \cdot 1,2 + 12,5 \cdot 1,2 \cdot 4 = 85,34 \text{ [Nm]}$$

$$T_{Kmax} = 85,34 \text{ Nm} < T_{cal}$$

T_{KN}	Coupling nominal torque	Nm
T_K	Motor-side nominal torque	Nm
T_{Kmax}	Coupling maximum torque	Nm
T_S	Motor peak torque	Nm
T_{AS}/T_{AI}	Driver-side peak torque	Nm
T_L	Acceleration delivered torque	Nm
T_{LS}/T_{LI}	Driven-side peak torque	Nm
V_R	Resonance factor	
V_{fi}	Torque amplification factor	
m	Mass factor	
J_A	Motor-side inertia	kgm^2
J_L	Driven-side inertia	kgm^2
Ψ	Dampening factor	

n_R	Resonance speed	min^{-1}
C_T	Torsional rigidity	Nm/rad
M_T	Transmissible torque moment	Nm
S_A	Motor-side shock factor	
S_L	Driven-side shock factor	
S_Z	Start frequency factor	
S_θ	Temperature factor	
S_D	Torsional rigidity factor	
S_f	Frequency factor	
T_W	Torque with reversal of the machine	Nm
T_{KW}	Torque with reversal transmissible by the coupling	Nm
T_{Cal}	Hub-shaft connection maximum torque	Nm

TRASCO® ES executions

GES F execution

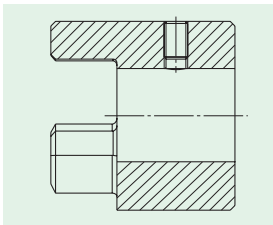

Hub execution with finish bore, and setscrew.

GES F C execution

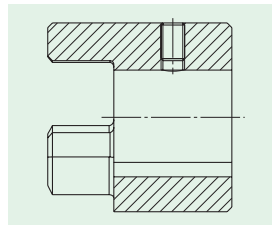

Hub execution with finish bore, keyway and setscrew. Not suitable for backlash free drives with heavy inversions or high startup frequency.

GES M execution

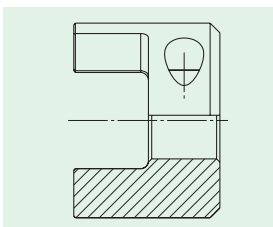

Clamping hub execution with single slot without keyway. Up to size 19/24. Backlash free hub design. Transmissible torque depends on bore diameter.

GES M execution

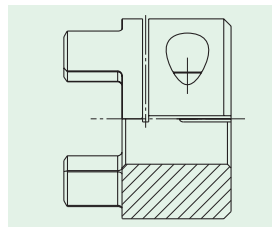

Clamping hub execution with double slot without keyway. From size 24/28. Backlash free hub design. Transmissible torque depends on bore diameter.

GES M...C execution

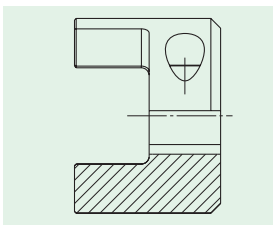

Camping hub execution with single slot and keyway. Up to size 19/24. The clamping pressure eliminates backlash in torque inversions.

GES M...C execution

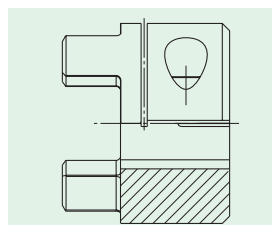

Camping hub execution with double slot and keyway. From size 24/28. The clamping pressure eliminates backlash in torque inversions.

GES 2M execution

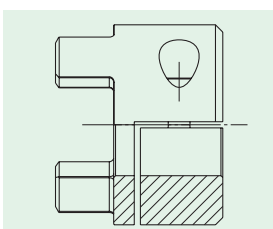

Split clamping hub execution for radial assembly of the coupling. Torque depends on bore diameter. Execution "C" with keyway, as option can be delivered for a positive torque transmission with zero backlash. These executions are suitable for double cardanic applications.

GES A execution

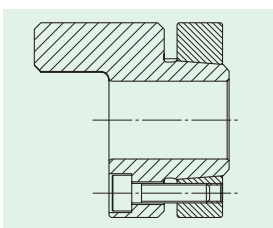

Execution with locking ring. This execution is suitable for high speed and high torque. Screws mounting from spider side. Transmissible torque depends on bore diameter.

GES AP execution

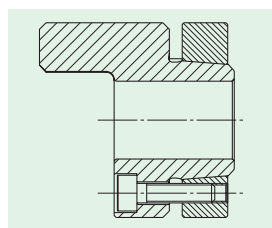

Execution with locking ring with high machining accuracy: design suitable for application on spindles according to DIN 69002.

Standard type

SIT coupling hubs are available from stock with either solid hub or with finished bores of standard shaft diameters. The setscrews of our finished bore execution are positioned 120 degrees from each other with one positioned 180 degrees from

the keyway. (see Fig. 1) Both the solid hub and bored hub coupling are generally available from stock for quick delivery.

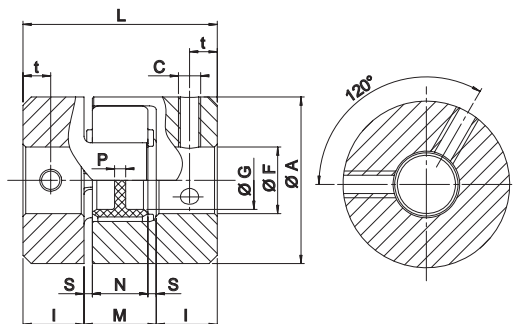

Fig. 1

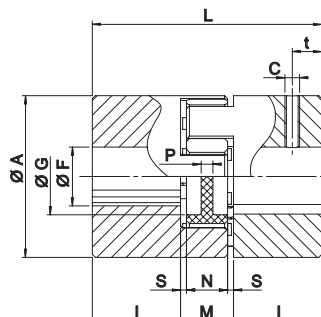

Fig. 2

Size	F min [mm]	F max [mm]	Hub		n _{max} [min ⁻¹]
			W [kg]	J [kgm ²]	
ALUMINUM HUBS					
7	3	7	0,003	0,085 x 10 ⁻⁶	40.000
9	4	9	0,009	0,49 x 10 ⁻⁶	28.000
14	4	15	0,020	2,8 x 10 ⁻⁶	19.000
19/24	6	24	0,066	20,4 x 10 ⁻⁶	14.000
24/28	8	28	0,132	50,8 x 10 ⁻⁶	10.600
28/38	10	38	0,253	200,3 x 10 ⁻⁶	8.500
38/45	12	45	0,455	400,6 x 10 ⁻⁶	7.100
STEEL HUBS					
42	14	55	2,000	2.246 x 10 ⁻⁶	6.000
48	20	60	2,520	3.786 x 10 ⁻⁶	5.600
55	25	70	4,100	9.986 x 10 ⁻⁶	5.000
65	25	80	5,900	18.352 x 10 ⁻⁶	4.600
75	30	95	6,900	27.464 x 10 ⁻⁶	3.700

A [mm]	G [mm]	L [mm]	I [mm]	M [mm]	N [mm]	S [mm]	P [mm]	c	t [mm]	Fig.
ALUMINUM HUBS										
14	-	22	7	8	6	1,0	6	M3	3,5	1
20	7,2	30	10	10	8	1,0	2	M3	5	1
30	10,5	35	11	13	10	1,5	2	M4	5	2
40	18	66	25	16	12	2,0	3,5	M5	10	2
55	27	78	30	18	14	2,0	4	M5	10	2
65	30	90	35	20	15	2,5	5,2	M6	15	2
80	38	114	45	24	18	3,0	5,6	M8	15	2
STEEL HUBS										
95	46	126	50	26	20	3,0	5,6	M8	20	2
105	51	140	56	28	21	3,5	6	M8	25	2
120	60	160	65	30	22	4,0	9	M10	20	2
135	68	185	75	35	26	4,5	8,3	M10	20	2
160	80	210	85	40	30	5	5	M10	25	2

Bore tolerance: H7 - JS9 (DIN 6985/1) keyway

Order form

Hub **GESF 24/28 F20**

GESP: solid hub
GESF: bore + keyway + set-screw

Size _____

F...: bore diameter _____

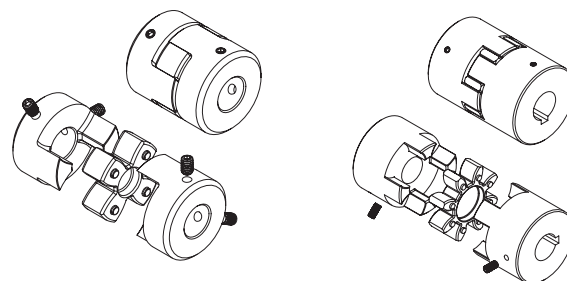

Spider **AES 24/28 R**

TRASCO® ES spider

Size _____

B: 80 Sh A (blue)
G: 92 Sh A (yellow)
R: 98 Sh A (red)
V: 64 Sh D (green)

W	Weight	kg
J	Moment of inertia	kgm ²
n _{max}	Maximum rpm	min ⁻¹

“M” execution with clamp hubs

This type of coupling permits quick, sure fixing, without any shaft-hub backlash.

With the keyless coupling type, the torque applied for tightening

down the screws (Ms) must be as given in the table.

The M coupling type is available with or without keyway.

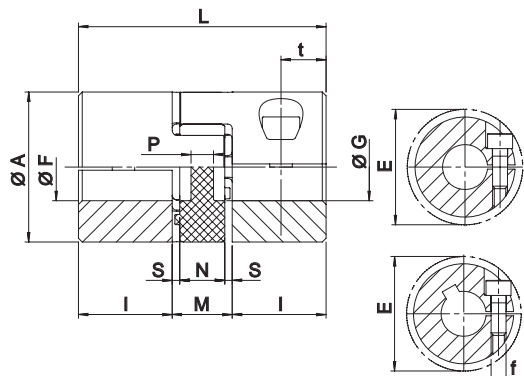

Fig. 1

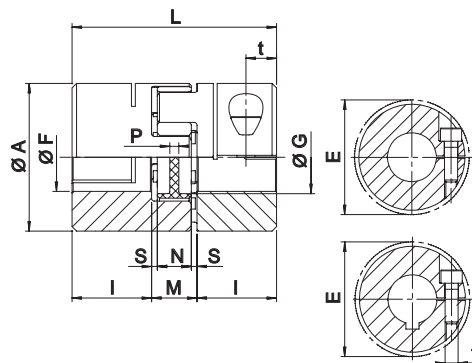

Fig. 2

Size	F min [mm]	F max [mm]	f	Ms [Nm]	Hub		n _{max} [min ⁻¹]
					W [kg]	J [kgm ²]	
ALUMINUM HUBS							
7	3	7	M2	0,35	0,003	0,085 x 10 ⁻⁶	40.000
9	4	9	M2,5	0,75	0,007	0,42 x 10 ⁻⁶	28.000
14	6	15	M3	1,4	0,018	2,6 x 10 ⁻⁶	19.000
19/24	10	20	M6	11	0,071	18,1 x 10 ⁻⁶	14.000
24/28	10	28	M6	11	0,156	74,9 x 10 ⁻⁶	10.600
28/38	14	35	M8	25	0,240	163,9 x 10 ⁻⁶	8.500
38/45	19	45	M8	25	0,440	465,5 x 10 ⁻⁶	7.100
STEEL HUBS							
42	25	50	M10	70	2,100	3.095 x 10 ⁻⁶	6.000
48	25	55	M12	120	2,900	5.160 x 10 ⁻⁶	5.600
55	35	70	M12	120	4,000	9.737 x 10 ⁻⁶	5.000
65	40	80	M14	190	5,800	17.974 x 10 ⁻⁶	4.600

Keyway position	A [mm]	G [mm]	L [mm]	I [mm]	M [mm]	N [mm]	S [mm]	P [mm]	t [mm]	E [mm]	Fig.
-	14	-	22	7	8	6	1,0	6	4	15,0	1
-	20	7,2	30	10	10	8	1,0	2	5	23,4	1
180°	30	10,5	35	11	13	10	1,5	2	5,5	32,2	1
120°	40	18	66	25	16	12	2,0	3,5	12	45,7	1
90°	55	27	78	30	18	14	2,0	4	12	56,4	2
90°	65	30	90	35	20	15	2,5	5,2	13,5	72,6	2
90°	80	38	114	45	24	18	3,0	5,6	16	83,3	2
STEEL HUBS											
-	95	46	126	50	26	20	3,0	5,6	20	78,8	2
-	105	51	140	56	28	21	3,5	6	21	108,0	2
-	120	60	160	65	30	22	4,0	9	26	122,0	2
-	135	68	185	75	35	26	4,5	8,3	27,5	139,0	2

From size 7 to 19/24: single slot execution
From size 24/28 to 65: double slot execution

Hub **GESM 48 F50**

GESM: TRASCO® ES hub

Size

F...: bore diameter
F...C: bore diameter and keyway

Spider **AES 24/28 R**

TRASCO® ES spider

Size

B: 80 Sh A (blue)
G: 92 Sh A (yellow)
R: 98 Sh A (red)
V: 64 Sh D (green)

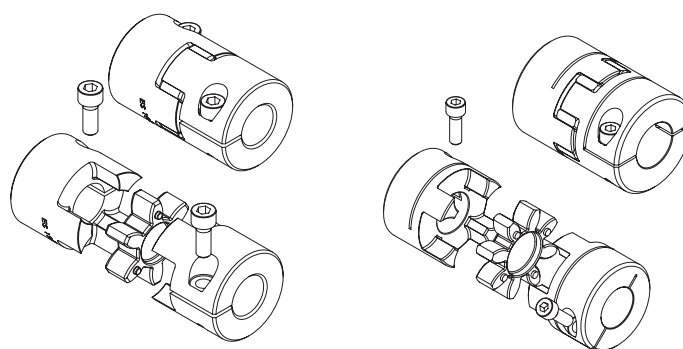

Fig. 1

Fig. 2

M _S	Screw tightening torque	Nm
W	Weight	kg
J	Coupling moment of inertia	kgm ²
n _{max}	Maximum rpm	min ⁻¹

Using hub execution **M** without keyway, the maximum transmissible torque is the minor between the clamp-hub transmissible torque and the value stated in the section “**Technical characteristics**”.

Size	Recommended M coupling Type Hub Bore Dia. [mm] and Transmissible Torque [Nm], Valid for shaft tolerances k6																																						
	Ø 4	Ø 5	Ø 6	Ø 7	Ø 8	Ø 9	Ø 10	Ø 11	Ø 12	Ø 14	Ø 15	Ø 16	Ø 19	Ø 20	Ø 22	Ø 24	Ø 25	Ø 28	Ø 30	Ø 32	Ø 35	Ø 38	Ø 40	Ø 42	Ø 45	Ø 48	Ø 50	Ø 55	Ø 60	Ø 65	Ø 70	Ø 75	Ø 80						
7	0,7	0,8	1	1,1																																			
9	1,1	1,4	1,7	1,9	2,2	2,5	2,8	3																															
14			2,5	2,9	3,3	3,7	4,1	4,6	5	5,8	6,2	6,6																											
19/24							23	25	27	32	34	36	43	45																									
24/28							23	25	27	32	34	36	43	45	50	54	57	63																					
28/38										58	62	66	79	83	91	100	104	116	124	133	145																		
38/45													79	83	91	100	104	116	124	133	145	158	166	174	187														
42																	217	243	261	278	304	330	348	365	391	417	435												
48																	299	335	359	383	419	455	479	503	539	575	599	659											
55																					356	387	407	428	458	489	509	560	611	662	713								
65																							558	586	628	670	697	767	837	907	976	1046	1116						

“A” type - Shrink disc execution

This type of coupling provides excellent kinetic uniformity. Furthermore, the absence of keys or grub screws makes it a well-balanced coupling and greatly facilitates installation and removal. An exact radial/axial positioning is easy for those

applications which require it. The absence of keyways also avoids fretting corrosion and backlash between the shaft and the hub. This is the ideal type of coupling for applications requiring precision and/or high rotational speeds.

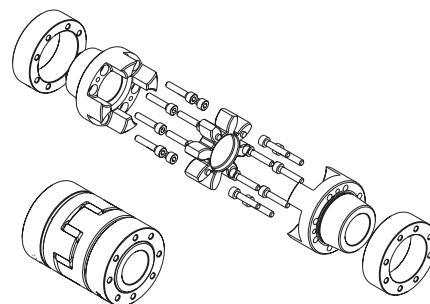
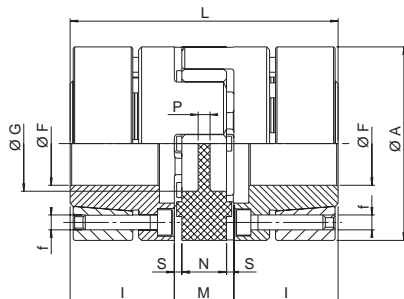

Size	F _{min} [mm]	F _{max} [mm]	f	Screws per locking elements	M _s [Nm]	Hub		n _{max} [min ⁻¹]
						W [kg]	J [kgm ²]	
ALUMINUM HUBS AND STEEL LOCKING ELEMENT								
14	6	14	M3	4	1,3	0,049	7 x 10 ⁻⁶	28.000
19/24	10	20	M4	6	2,9	0,120	30 x 10 ⁻⁶	21.000
24/28	15	28	M5	4	6,0	0,280	135 x 10 ⁻⁶	15.500
28/38	19	38	M5	8	6,0	0,450	315 x 10 ⁻⁶	13.200
38/45	20	45	M6	8	10,0	0,950	960 x 10 ⁻⁶	10.500
STEEL HUBS AND LOCKING ELEMENT								
42	28	50	M8	4	35,0	2,300	3.150 x 10 ⁻⁶	9.000
48	35	60	M8	4	35,0	3,080	5.200 x 10 ⁻⁶	8.000
55	38	65	M10	4	71,0	4,670	10.300 x 10 ⁻⁶	6.300
65	40	70	M12	4	120,0	6,700	19.100 x 10 ⁻⁶	5.600

A [mm]	G [mm]	L [mm]	I [mm]	M [mm]	N [mm]	S [mm]	P [mm]
ALUMINUM HUBS AND STEEL LOCKING ELEMENT							
30	10,5	50	18,5	13	10	1,5	2
40	18	66	25	16	12	2,0	3,5
55	27	78	30	18	14	2,0	4
65	30	90	35	20	15	2,5	5,2
80	38	114	45	24	18	3,0	5,6
STEEL HUBS AND LOCKING ELEMENT							
95	46	126	50	26	20	3,0	5,6
105	51	140	56	28	21	3,5	6
120	60	160	65	30	22	4	9
135	68	185	75	35	26	4,5	8,3

Using hub execution **A**, the shrink-disc maximum transmissible torque is the minor between the value stated in the table

below and the value stated in section “**Technical characteristics**”.

Size	Recommended A coupling Type Hub Bore Dia. [mm] and Transmissible Torque [Nm], valid for shaft tolerances k6																										
	Ø 10	Ø 11	Ø 14	Ø 15	Ø 16	Ø 17	Ø 18	Ø 19	Ø 20	Ø 22	Ø 24	Ø 25	Ø 28	Ø 30	Ø 32	Ø 35	Ø 38	Ø 40	Ø 42	Ø 45	Ø 48	Ø 50	Ø 55	Ø 60	Ø 65	Ø 70	
14	10	12	22																								
19/24	42	46	60	65	69	74	79	84	88																		
24/28				66	72	77	82	87	92	102	113	118	135														
28/38								175	185	205	225	235	266	287	308	339	373										
38/45									255	283	312	326	367	398	427	471	515	545	577	620							
42													420	460	500	563	627	670	714	790	850	880					
48															557	612	649	687	744	801	840	932	1033				
55																986	1112	1140	1185	1284	1412	1420	1652	1680	1691		
65																	1531	1580	1772	1840	1960	2049	2438	2495	2590		

Order form

Hub **GESA 48 F45**

GESA: TRASCO® ES hub - “A” execution

Size

F...: bore diameter

Spider **AES 24/28 R**

TRASCO® ES spider

Size

B: blue; G: yellow; R: red; V: green

M _s	Screw tightening torque	Nm
W	Weight	kg
J	Coupling moment of inertia	kgm ²
n _{max}	Maximum rpm	min ⁻¹

“AP” type - Shrink disc execution according to DIN 69002

Precision “zero-backlash” coupling designed for multi spindle devices on machine tools or controls with reduced mass, such as short center spindles, multi-centers primary spindles in work sta-

tions, or joined to high speed bearings with limited tolerance range. It is suitable for very high speeds of rotation (up to speeds of 50 m/s).

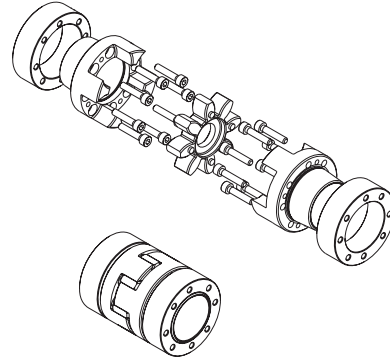
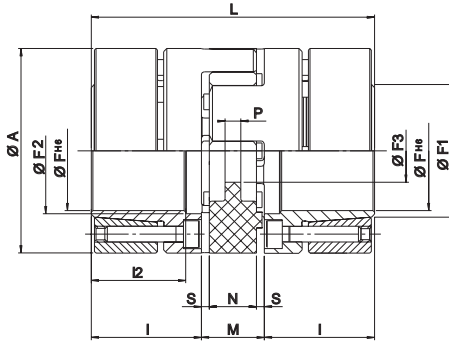

Size	F ^{H6} [mm]	M _S [Nm]	Hub		n _{max} [min ⁻¹]
			W [kg]	J [kgm ²]	
STEEL HUBS AND LOCKING ELEMENT					
14	14	1,89	0,080	11 x 10 ⁻⁶	28.000
19/24 - 37,5	16	3,05	0,160	37 x 10 ⁻⁶	21.000
19/24	19	30,5	0,190	46 x 10 ⁻⁶	21.000
24/28-50	24	4,90	0,330	136 x 10 ⁻⁶	15.500
24/28	25	8,50	0,440	201 x 10 ⁻⁶	15.500
28/38	35	8,50	0,640	438 x 10 ⁻⁶	13.200
38/45	40	14,00	1,320	1.325 x 10 ⁻⁶	10.500
42	42	35,00	2,230	3.003 x 10 ⁻⁶	9.000
48	45	35,00	3,090	5.043 x 10 ⁻⁶	8.000
55	50	69,00	4,740	10.020 x 10 ⁻⁶	6.300

A [mm]	L [mm]	I [mm]	I2 [mm]	M [mm]	N [mm]	S [mm]	P [mm]	F1 [mm]	F2 [mm]	F3 [mm]
STEEL HUBS AND LOCKING ELEMENT										
32	50	18,5	15,5	13	10	1,5	2	17	17	8,5
37,5	66	25	21	16	12	2,0	3,5	20	19	9,5
40	66	25	21	16	12	2,0	3,5	24	22	9,5
50	78	30	25	18	14	2,0	4	28	29	12,5
55	78	30	25	18	14	2,0	4	35	30	12,5
65	90	35	30	20	15	2,5	5,2	40	40	14,5
80	114	45	40	24	18	3,0	5,6	46	46	16,5
92	126	50	45	26	20	3,0	5,6	52	55	18,5
105	140	56	50	28	21	3,5	6	52	60	20,5
120	160	65	58	30	22	4	9	55	72	22,5

Spindle size	TRASCO® ES "AP"	98 Sh. A		64 sh. D	
		TKN [Nm]	TKmax [Nm]	TKN [Nm]	TKmax [Nm]
25 x 20	14	12,5	25	16	32
32 x 25	19/24 - 37,5	14	28	17	34
32 x 30	19/24	17	34	21	42
40 x 35	24/28 - 50	43	86	54	108
50 x 45	24/28	60	120	75	150
63 x 55	28/38	160	320	200	400

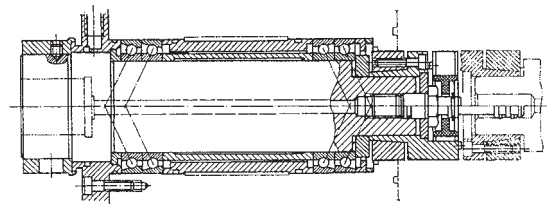

Order form

Hub **GESAP 48 F45**

GESAP:TRASCO® ES hub - "AP" execution

Size

F...: bore diameter

Spider

AES 24/28 R

TRASCO® ES spider

Size

B: blue; G: yellow; R: red; V: green

M _S	Screw tightening torque	Nm
W	Weight	kg
J	Coupling moment of inertia	kgm ²
n _{max}	Maximum rpm	min ⁻¹

“GESS” double cardanic execution

This execution allows higher misalignments. The 2 spiders allow a high vibration dampening providing a decrease in drive noise and longer life of related components (ex. bearings).

The intermediate element is made of aluminum alloy and may be used in combination with any type of hub execution.

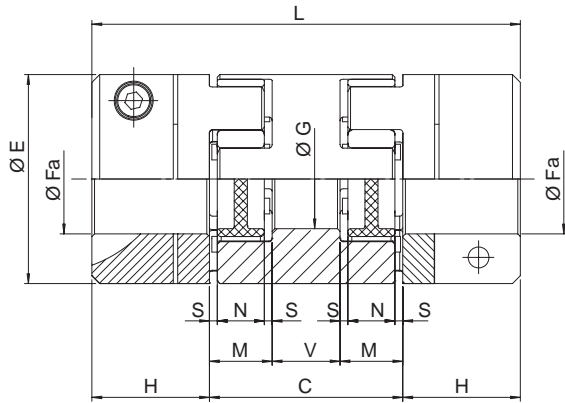

Fig.1

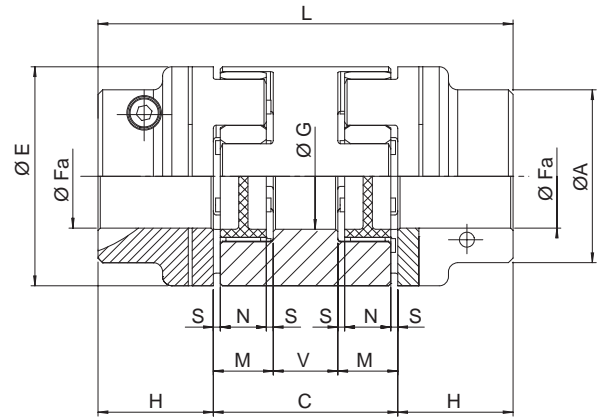

Fig.2

Size	Fa min [mm]	Fa max [mm]	E [mm]	A [mm]	C [mm]	H [mm]	L [mm]	V [mm]	M [mm]	S [mm]	N [mm]	G [mm]	W [kg]	J [kg m ²]	Fig.
ALUMINUM HUBS ALUMINUM GESS															
7	3	7	14	–	20	7	34	4	8	1	6	–	0,003	0,0000008	1
9	4	9	20	–	25	10	45	5	10	1	8	–	0,007	0,0000004	1
14	6	15	30	–	34	11	56	8	13	1,5	10	–	0,024	0,000003	1
19/24	10	20	40	–	42	25	92	10	16	2	12	18	0,05	0,000013	1
24/28	10	28	55	–	52	30	112	16	18	2	14	27	0,14	0,00006	1
28/38	14	35	65	–	58	35	128	18	20	2,5	15	30	0,22	0,00013	1
38/45	15	45	80	–	68	45	158	20	24	3	18	38	0,35	0,00035	1
STEEL HUBS ALUMINUM GESS															
42	20	45	95	75	74	50	174	22	26	3	20	46	0,51	0,0007	2
48	25	60	105	85	80	56	192	24	28	3,5	21	51	0,67	0,001	2
55	25	70	120	110	88	65	218	28	30	4	22	60	0,97	0,002	2
65	25	75	135	115	102	75	252	32	35	4,5	26	68	1,43	0,004	2

Order form

Spacer element

GESS 24

GESS: spacer element

Size: 24/28

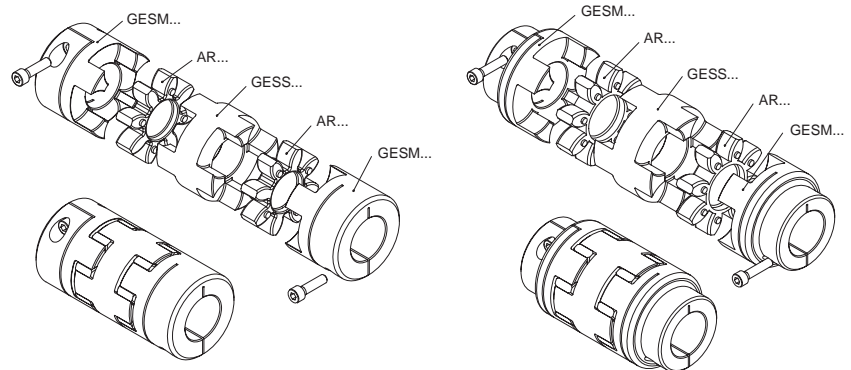

W	Weight	kg
J	Coupling moment of inertia	kgm ²

“GES LR1” execution with intermediate shaft

This zero backlash execution, allows connection to long distance shafts in applications such as lifting screw jacks, gantry robot etc. The intermediate shaft is made of steel but may be of different

material for specific need. The presence of 2 spiders, increases the dampening properties and allow high misalignments.

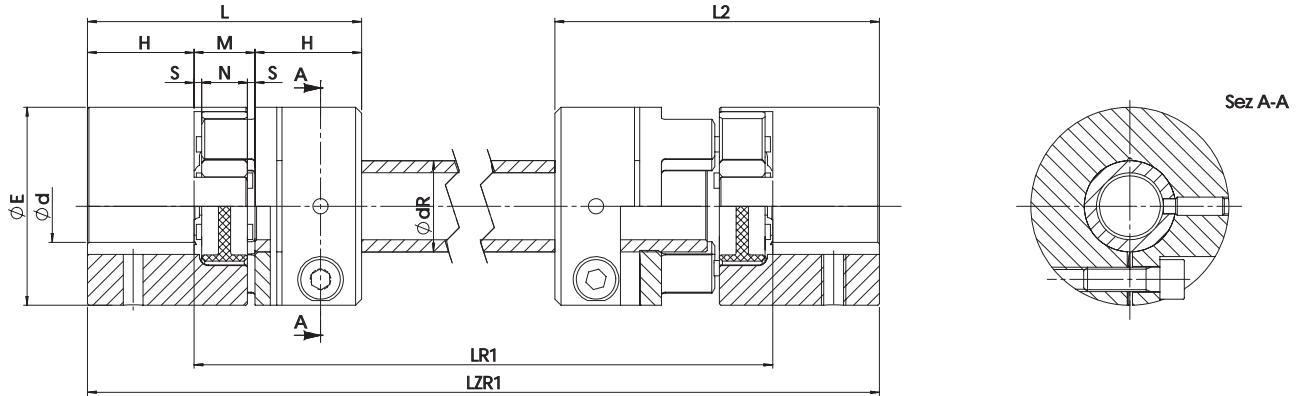

Size	External hub		Internal hub		
	Dimensions finished bores		Screws Din912-8.8 M-L	Ms [N·m]	Mt [N·m]
	dmin [mm]	dmax [mm]			
14	4	15	M3x12	1,4	6
19/24	6	24	M6x15	10	35
24/28	8	28	M6x20	10	46
28/38	10	38	M8x25	25	108
38/45	12	45	M8x30	25	125

E [mm]	H [mm]	L [mm]	M [mm]	N [mm]	s [mm]	L2 [mm]	LR1 [mm]	LR1 min [mm]	LZR1 [mm]	dR x tightening [mm]
30	11	35	13	10	1,5	48	On request	71	LR1+22	14 x 2.0
40	25	66	16	12	2	82		110	LR1+50	20 x 3.0
55	30	78	18	14	2	96		128	LR1+60	25 x 2.5
65	35	90	20	15	2,5	110		145	LR1+70	35 x 4.0
80	45	114	24	18	3	138		180	LR1+90	40 x 4.0

Coupling configurator

Coupling code	Item	Type	Execution	Bore diameter	Order example	
GESL38/45	Hub 1	GESP	-	-	GESF38/45F35	
		GESF	-	F...		
		GESM	F-C	F...		
		GESA	-	F...		
	Spider 1	AES	B-G-R-V	-	AES38/45V	
	Length LR1					LR1= 1200 mm
	Spider 2	AES	B-G-R-V	-	AES38/45V	
	Hub 2	GESP	-	-	GESF38/45F35	
		GESF	-	F...		
		GESM	F-C	F...		
GESA		-	F...			

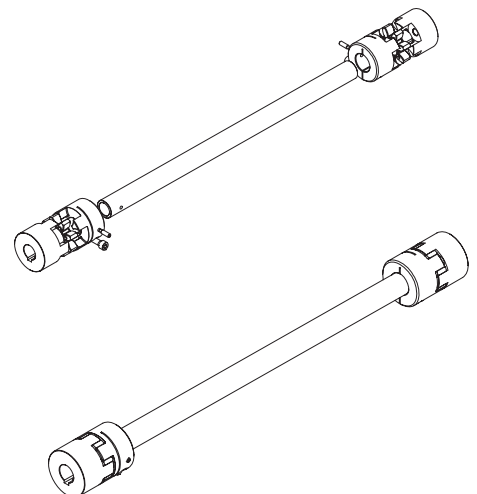

Ms Screw tightening torque Nm
Mt Transmissible torque moment Nm

“GES LR3” execution with intermediate shaft

Ideal execution for long distance shaft connections. Torque transmission is zero backlash. It is used in applications such as automatic machines, lifting machines, palletizing machines, and handling machines. Designed for length up to 4 m without

bearing support (depending on rotation speed). The double slot execution, allows spider mounting and replacement without driver/driven machine displacement. All aluminum alloy for a very low inertia.

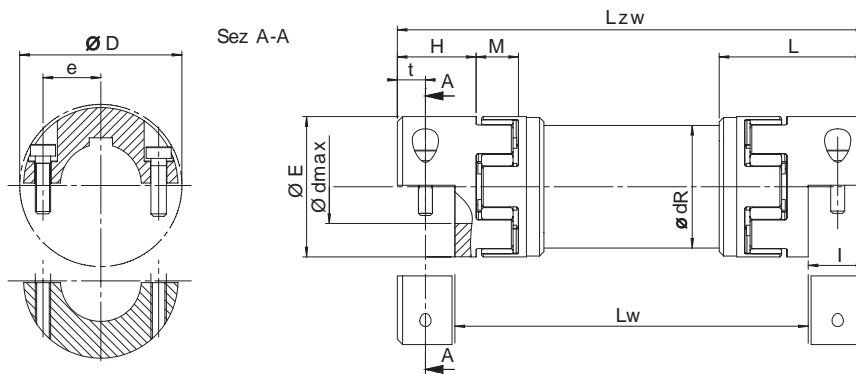

Size	Dimensions finished bores		Clamping		Moment of inertia [10 ⁴ kgm ²] with d _{max} hub 1			Torsional rigidity
	d _{min} [mm]	d _{max} [mm]	Screws DIN 4762-8.8	M _s [Nm]	Hub 1 J ₁	Hub 2 J ₂	Shaft J ₃	C _T [Nm/rad]
19	8	20	M6	10	0,02002	0,01304	0,340	3003
24	10	28	M6	10	0,07625	0,04481	0,0697	6139
28	14	38	M8	25	0,17629	0,1095	1,243	10936
38	18	45	M8	25	0,50385	0,2572	3,072	27114
42	22	50	M10	49	1,12166	0,5523	4,719	41591
48	22	55	M12	86	1,87044	1,1834	9,591	84384

E [mm]	H [mm]	I [mm]	L [mm]	M [mm]	L _w [mm]	L _w min [mm]	L _{zw} [mm]	D [mm]	t [mm]	e [mm]	d _R [mm]
40	25	17,5	49	16	Length on request	98	L _w +35	47	8	14,5	40
55	30	22	59	18		113	L _w +44	57	10,5	20	50
65	35	25	67	20		131	L _w +50	73	11,5	25	60
80	45	33	83,5	24		163	L _w +66	84	15,5	30	70
95	50	36,5	93	26		180	L _w +73	94	18	32	80
105	56	39,5	103	28		202	L _w +79	105	18,5	36	100

Coupling configurator

Coupling code	“AP”	Type	Execution	Bore diameter	Order example	
GESLR38/45	Hub 1	GESP	-	-	GESM38/45F35	
		GESF	-	F...		
		GESM	F-C	F...		
		GESA	-	F...		
	Spider 1	AES	B-G-R-V	-	AES38/45V	
	Distanza tra gli alberi L _w					L _w = 1200 mm
	Spider 2	AES	B-G-R-V	-	AES38/45V	
	Hub 2	GESP	-	-	GESM38/45F35	
GESF		-	F...			
GESM		F-C	F...			
GESA		-	F...			

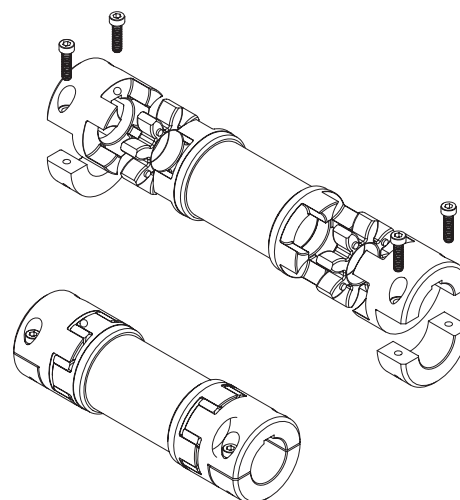

M _s	Screw tightening torque	Nm
J	Coupling moment of inertia	kgm ²
C _T	Torsional rigidity	Nm/rad

Size	Bores and torques for friction with hub without keyway [Nm]																							
	Ø 8	Ø 10	Ø 11	Ø 14	Ø 15	Ø 16	Ø 18	Ø 19	Ø 20	Ø 22	Ø 24	Ø 25	Ø 28	Ø 30	Ø 32	Ø 35	Ø 38	Ø 40	Ø 42	Ø 45	Ø 46	Ø 48	Ø 50	Ø 55
19	17	21	23	30	32	34	38	40	42															
24		21	23	30	32	34	38	40	42	47	51	53	59											
28				54	58	62	70	74	78	86	93	97	109	117	124	136	148							
38							70	74	78	86	93	97	109	117	124	136	148	156	163	175				
42										136	149	155	174	186	198	217	235	248	260	279	285	297	310	
48										199	217	226	253	271	290	317	344	362	380	407	416	434	452	498

Technical data for intermediate shaft couplings (GES LR1 - GES LR3)

Size	Misalignment	
	Assial ΔK_a [mm]	Angular ΔK_w [°]
14	1,0	0,9
19/24	1,2	0,9
24/28	1,4	0,9
28/38	1,5	0,9
38/45	1,8	0,9

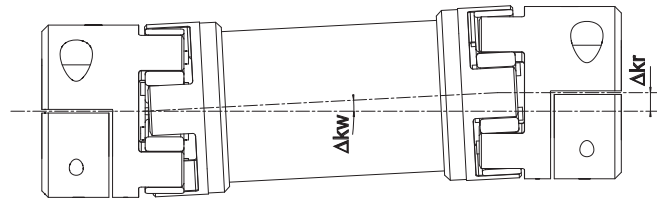

Radial misalignment

$$\Delta K_r = (L_z - 2 \cdot H - M) \cdot \tan(\Delta K_w) \quad [\text{mm}]$$

Angular misalignment = 0,9° per spider

$$C_{\text{Tot}} = \frac{1}{2 \cdot \frac{1}{C_{\text{T spider}}} + \frac{L_{\text{intermediate shaft}}}{C_{\text{T intermediate shaft}}}} \quad [\text{Nm/rad}]$$

$$L_{\text{intermediate shaft}} = \frac{L_{zw} - 2 \cdot L}{1000} \quad [\text{mm}]$$

with L_{zw} = total coupling length

Selection diagram GES LR3 coupling

