



Flyerketten
Leaf chains





ELITE® Flyerketten Leaf chains

ELITE-Flyerketten werden überall dort eingesetzt, wo Lasten gehoben oder gezogen werden und wo es demzufolge auf hohe Bruchkräfte ankommt. Die weiteste Verwendung finden ELITE-Flyerketten in Hubmasten von Gabelstaplern, aber auch als Gegengewichtsketten bei Werkzeugmaschinen, als Ziehbankketten oder in Containerhubwagen werden sie eingesetzt.

Im Gegensatz zu Rollenketten bestehen Flyerketten nur aus Bolzen und Laschen, wodurch die sehr hohen Bruchkräfte erreicht werden. Diese gehen zulasten der Verschleißfestigkeit, da den Ketten das klassische Gelenk aus Bolzen und Buchse fehlt.

Bezeichnung von Flyerketten

Flyerketten können nach ISO 4347 synonym bezeichnet werden. So entsprechen die Flyerketten der LH-Serie der BL-Serie und die Ketten der LL-Serie werden oft als F-Serie bezeichnet. Hintergrund ist die Zusammenlegung amerikanischer und europäischer Normen und Sprachgebräuche in einer Norm.

Flyerketten mit der Vorsilbe „LH“ [„BL“] basieren auf der ANSI-Kettenreihe nach ISO 606, Flyerketten mit der Vorsilbe „LL“ [F] entsprechen dem British Standard nach ISO 606. Danach folgt eine vierstellige Nummer, wobei die ersten beiden Ziffern die Kettenteilung repräsentieren. Dividiert man diese durch sechzehn, so erhält man die Teilung der Kette in Zoll. Die beiden letzten Ziffern beschreiben die Laschenanordnung (Anzahl der Laschen im Außen- und Innenglied).

Bei der amerikanischen Kettenbezeichnung „BL“ wird dasselbe Prinzip angewendet wobei man die Kettenteilung in Zoll erhält, indem man die erste (bis 1,0 Zoll Teilung) bzw. die ersten beiden Ziffern (ab 1,25 Inch Teilung) durch acht dividiert. Bei Ketten der Serie „LL“ [F] stellen die ersten beiden Ziffern die Teilung dar, wenn sie auf das nächsthöhere Zollmaß aufgerundet werden.

ELITE-Highlights

- ELITE-Kettenlaschen **1** mit optimierter Geometrie, präzise geformt und wärmebehandelt, sind tailliert, kugelgestrahlt und verfügen über besonders hohe Traganteile.
- Seine glatte, hochfeste Oberfläche verleiht dem ELITE-Bolzen **2** eine erhöhte Verschleißfestigkeit.

ELITE leaf chains are used wherever loads must be lifted, hoisted or pulled and high fatigue strength is crucial to function and safety. The most common use of ELITE leaf chains is in forklift truck masts, but they are also used as counterbalance chains in machine tools, as draw bench chains or in container pallet jacks.

Unlike roller chains, leaf chains have very high fatigue strength values, since they consist only of pins and plates. High fatigue strength is gained at the expense of wear resistance, because leaf chains do not have the classic pin and bush bearings common to other chains.

Classification of leaf chains

Leaf chains can be classified synonymously according to standard ISO 4347. Leaf chains from the LH series correspond with the BL series, and LL series chains are commonly referred to as F series. This is a result of the harmonisation of American and European standards and language conventions in a single unified standard.

Leaf chains with the prefix “LH” [“BL”] are based on the ANSI chain series according to ISO 606, leaf chains with the prefix “LL” [F] correspond with the British Standard series according to ISO 606. The prefix is followed by a four-digit number whose first two digits represent the chain pitch. Dividing of the latter by 16 gives the chain pitch in inches. The last two digits denote the plate configuration (number of plates in outer and inner link).

The same principle applies to the American “BL” chain classification, except that the chain pitch in inches is obtained by dividing the first digit (pitch up to 1.0 inch) or the first two digits (for pitches of 1.25 inches or more) by eight rather than 16. In the case of series “LL” [F] chains, the first two digits are rounded up to the next full inch to obtain the pitch figure.

ELITE highlights

- ELITE chain plates **1** with optimum geometry are precision-formed and heat-treated. The tapered and shot-blasted chain plates also have particularly high contact ratios.
- ELITE pins **2** are smooth and have an extra hard surface for increased wear resistance



ELITE-Flyerketten

Baureihe LH [BL] – amerikanische Bauart, verstärkte Bauart

(ISO 4347 und DIN 8152)

Bei dieser Baureihe werden die Abmessungen der Rollenkette nach ANSI Standard verwendet, sie entsprechen jedoch im Bolzendurchmesser und in der Laschendicke der jeweils nächstgrößeren Kettentype.

Baureihe LL [F] – europäische Bauart, leichte Bauart

(ISO 4347 und DIN 8152)

Bei dieser Baureihe werden die Abmessungen der Rollenkette nach DIN 8187 verwendet.

Baureihe AL – amerikanische Bauart, leichte Reihe

Die Flyerketten entsprechen einer alten amerikanischen Norm. Diese ist seit einigen Jahren zurückgezogen. Dennoch finden die Ketten vereinzelt Anwendung. Es werden bei diesen Ketten die Abmessungen nach ANSI Standard verwendet.

Anwendungsbereiche

- Gabelstapler
- Hubgeräte
- Werkzeugmaschinen
- Stahlindustrie
- Containerhubwagen
- ... und viele mehr

Produktprogramm

- Flyerketten verstärkte Baureihe LH [BL] nach amerikanischer Bauart
- Flyerketten leichte Baureihe LL [F] nach europäischer Bauart
- Flyerketten der Baureihe AL
- Flyerketten mit Schlauchführung und Hydraulikmastschutz für Gabelstapler

Weitere ELITE-Vorteile

- Breites Produktprogramm
- Viele weitere Sondervarianten nach Werknormen lieferbar

ELITE leaf chains

Series LH [BL] – American type, heavy series

(ISO 4347 und DIN 8152)

For this series, the link plate dimensions of roller chains manufactured according to ANSI Standard are used, but the pin diameter and thickness of the link plate correspond to the next larger chain size.

Series LL [F] – European type, light series

(ISO 4347 und DIN 8152)

For this series, the dimensions of roller chains according to DIN 8187 are used.

Series AL – American type, light series

These leaf chains correspond to the old American standard. Although this standard was withdrawn several years ago, the chains are still used occasionally. The applicable dimensions are according to ANSI Standard.

Industries and applications

- Forklift trucks
- Lifting devices
- Machine tools
- Steelmaking industry
- Container pallet jacks
- ... and much more besides

Product range

- Leaf chains heavy series LH [BL], American type
- Leaf chains light series LL [F], European type
- Leaf chains series AL
- Leaf chains with tube guide and hydraulic mast protection for forklift trucks

Additional ELITE benefits

- Wide range of products
- Many other special variants manufactured to factory standards available

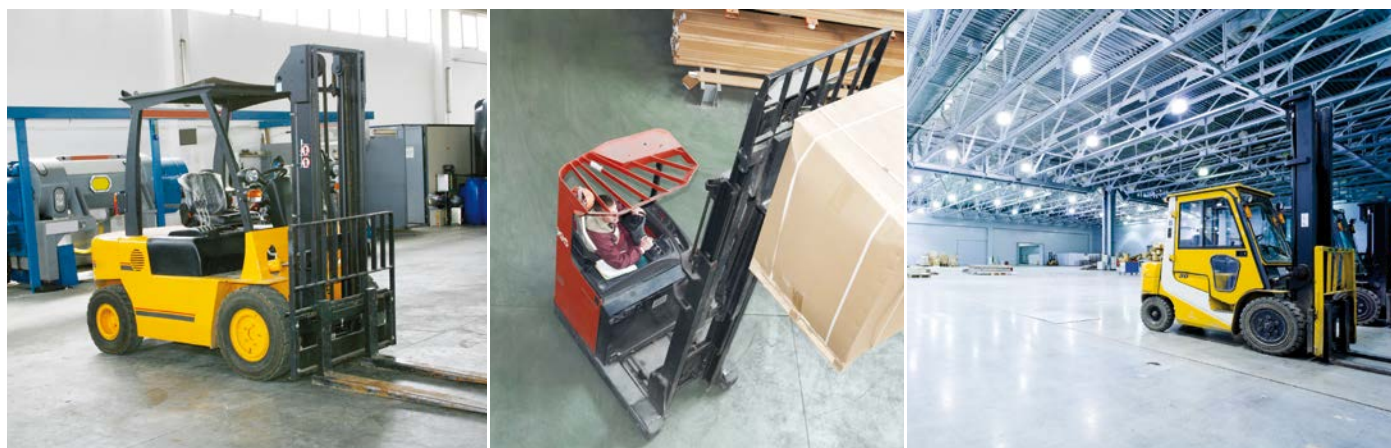



Flyerketten schwere Baureihe BL nach amerikanischer Norm

Leaf chains heavy series BL according to American standard ISO 4347/DIN 8152

Kettentyp		Teilung	Laschenkombination	Laschenhöhe	Laschendicke	Bolzen-Ø	Bolzenlänge	Min. Bruchkraft ISO/DIN Standard	Mittlere Bruchkraft	Gewicht pro Meter	Verbindungsbolzen		
Chain type		Pitch	Plate lacing	Plate depth	Plate thickness	Pin Ø	Pin length	Min. tensile strength ISO/DIN	Avg. tensile strength	Weight per meter	Clevis pins		
ANSI	ISO	p mm		h2 max. mm	T max. mm	d2 max. mm	b4 max. mm	FU kN	FB kN	q kg/m	d3 mm	L1 mm	x mm
LH0822	BL422	12,7	2 x 2	12	2,0	5,09	11,0	22,2	23,6	0,6	1,6	14,8	8,8
LH0823	BL423	12,7	2 x 3	12	2,0	5,09	13,2	22,2	24,5	0,8	1,6	17,0	11,0
LH0834	BL434	12,7	3 x 4	12	2,0	5,09	17,4	33,4	42,7	1,1	1,6	21,4	15,4
LH0844	BL444	12,7	4 x 4	12	2,0	5,09	19,5	44,5	57,8	1,3	1,6	23,5	17,5
LH0846	BL446	12,7	4 x 6	12	2,0	5,09	23,8	44,5	55,4	1,6	1,6	29,9	21,9
LH0866	BL466	12,7	6 x 6	12	2,0	5,09	28,0	66,7	86,9	1,9	1,6	32,3	26,3
LH0888	BL488	12,7	8 x 8	12	2,0	5,09	36,4	88,8	112,0	2,6	1,6	41,8	35,5
LH1022	BL522	15,875	2 x 2	15	2,4	5,96	12,9	33,4	41,8	0,9	2,0	17,7	10,5
LH1023	BL523	15,875	2 x 3	15	2,4	5,96	15,4	33,4	42,2	1,1	2,0	20,3	13,1
LH1034	BL534	15,875	3 x 4	15	2,4	5,96	20,3	48,9	63,0	1,5	2,0	25,5	18,3
LH1044	BL544	15,875	4 x 4	15	2,4	5,96	22,9	66,7	90,8	1,8	2,0	28,0	20,9
LH1046	BL546	15,875	4 x 6	15	2,4	5,96	27,5	66,7	88,9	2,2	2,0	33,2	26,0
LH1066	BL566	15,875	6 x 6	15	2,4	5,96	33,1	100,9	130,0	2,6	2,0	38,5	31,2
LH1088	BL588	15,875	8 x 8	15	2,4	5,96	42,2	133,6	159,6	3,5	2,0	48,8	41,7
LH1222	BL622	19,05	2 x 2	18,1	3,2	7,94	17,4	48,9	63,2	1,4	3,2	25,0	14,2
LH1223	BL623	19,05	2 x 3	18,1	3,2	7,94	20,0	48,9	71,0	1,8	3,2	28,5	17,7
LH1234	BL634	19,05	3 x 4	18,1	3,2	7,94	27,4	75,6	110,3	2,5	3,2	35,5	24,7
LH1244	BL644	19,05	4 x 4	18,1	3,2	7,94	29,8	97,6	143,1	2,9	3,2	38,8	28,3
LH1246	BL646	19,05	4 x 6	18,1	3,2	7,94	37,5	97,6	145,5	3,6	3,2	46,0	35,2
LH1266	BL666	19,05	6 x 6	18,1	3,2	7,94	43,1	146,8	213,9	4,3	3,2	52,8	42,5
LH1288	BL688	19,05	8 x 8	18,1	3,2	7,94	56,4	195,6	234,9	5,8	3,2	66,8	56,6

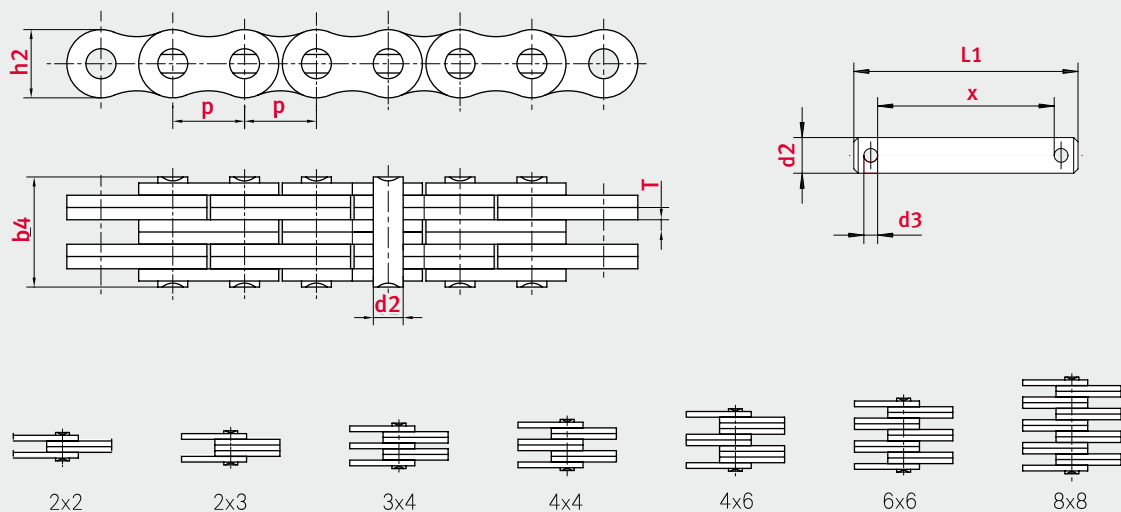



Flyerketten schwere Baureihe BL nach amerikanischer Norm

Leaf chains heavy series BL according to American standard ISO 4347/DIN 8152

Kettentyp		Teilung	Laschen- kombination	Laschenhöhe	Laschendicke	Bolzen-Ø	Bolzenlänge	Min. Bruchkraft ISO/DIN Standard	Mittlere Bruchkraft	Gewicht pro Meter	Verbindungsbolzen		
Chain type		Pitch	Plate lacing	Plate depth	Plate thickness	Pin Ø	Pin length	min. tensile strength ISO/DIN	Avg. tensile strength	Weight per meter	Clevis pins		
ANSI	ISO	p mm		h2 max. mm	T max. mm	d2 max. mm	b4 max. mm	FU kN	FB kN	q kg/m	d3 mm	L1 mm	x mm
LH1622	BL822	25,4	2 x 2	24,1	4,0	9,54	20,7	84,5	111,2	2,2	3,2	28,5	17,8
LH1623	BL823	25,4	2 x 3	24,1	4,0	9,54	25,5	84,5	115,6	2,7	3,2	32,9	22,1
LH1634	BL834	25,4	3 x 4	24,1	4,0	9,54	33,8	129,0	172,0	3,8	3,2	41,7	30,8
LH1644	BL844	25,4	4 x 4	24,1	4,0	9,54	37,9	169,0	243,9	4,3	3,2	47,7	37,0
LH1646	BL846	25,4	4 x 6	24,1	4,0	9,54	45,7	169,0	224,2	5,4	3,2	54,8	43,8
LH1666	BL866	25,4	6 x 6	24,1	4,0	9,54	54,5	253,6	345,2	6,5	3,2	63,3	52,4
LH1688	BL888	25,4	8 x 8	24,1	4,0	9,54	71,0	338,1	454,5	8,6	3,2	81,2	69,9
LH2022	BL1022	31,75	2 x 2	30,1	4,8	11,1	25,4	115,6	122,7	3,4	3,2	36,8	26,2
LH2023	BL1023	31,75	2 x 3	30,1	4,8	11,1	30,3	115,6	193,8	4,3	3,2	37,0	26,1
LH2034	BL1034	31,75	3 x 4	30,1	4,8	11,1	39,9	182,4	251,0	6,0	3,2	47,2	35,5
LH2044	BL1044	31,75	4 x 4	30,1	4,8	11,1	43,8	231,3	331,6	6,9	3,2	39,9	52,0
LH2046	BL1046	31,75	4 x 6	30,1	4,8	11,1	53,5	231,3	336,2	8,6	3,2	63,0	50,2
LH2066	BL1066	31,75	6 x 6	30,1	4,8	11,1	64,5	347,0	478,0	10,3	3,2	71,4	59,3
LH2088	BL1088	31,75	8 x 8	30,1	4,8	11,1	84,8	462,4	730,0	13,8	3,2	92,4	79,9
LH2422	BL1222	38,1	2 x 2	36,2	5,5	12,7	29,6	151,2	210,4	4,6	4,0	36,9	24,5
LH2423	BL1223	38,1	2 x 3	36,2	5,5	12,7	35,4	151,2	222,5	5,8	4,0	41,8	30,0
LH2434	BL1234	38,1	3 x 4	36,2	5,5	12,7	45,4	244,6	348,0	8,1	4,0	54,8	41,8
LH2444	BL1244	38,1	4 x 4	36,2	5,5	12,7	51,1	302,5	410,3	9,3	4,0	60,0	46,3
LH2446	BL1246	38,1	4 x 6	36,2	5,5	12,7	62,5	302,5	496,0	11,6	4,0	72,8	59,7
LH2466	BL1266	38,1	6 x 6	36,2	5,5	12,7	73,9	453,7	722,6	13,9	4,0	86,1	71,3
LH2488	BL1288	38,1	8 x 8	36,2	5,5	12,7	99,4	604,8	948,0	18,6	4,0	111,1	98,6
LH2822	BL1422	44,45	2 x 2	42,2	6,5	14,3	33,5	191,3	230,0	6,1	4,0	39,4	27,6
LH2823	BL1423	44,45	2 x 3	42,2	6,5	14,3	40,2	191,3	230,0	7,6	4,0	46,9	33,9
LH2834	BL1434	44,45	3 x 4	42,2	6,5	14,3	53,0	315,8	360,0	10,6	4,0	60,3	46,9
LH2844	BL1444	44,45	4 x 4	42,2	6,5	14,3	60,0	382,6	450,0	12,2	4,0	71,1	58,6
LH2846	BL1446	44,45	4 x 6	42,2	6,5	14,3	72,3	382,6	483,0	15,2	4,0	80,2	67,1
LH2866	BL1466	44,45	6 x 6	42,2	6,5	14,3	85,5	578,3	948,0	18,2	4,0	97,7	85,1
LH2888	BL1488	44,45	8 x 8	42,2	6,5	14,3	112,8	765,2	1080,0	24,3	4,0	121,6	108,6
LH3222	BL1622	50,8	2 x 2	48,2	7,2	17,5	39,0	289,1	325,0	8,0	-	-	-
LH3223	BL1623	50,8	2 x 3	48,2	7,2	17,5	46,6	289,1	340,0	10,0	5,0	51,3	37,6
LH3234	BL1634	50,8	3 x 4	48,2	7,2	17,5	59,9	440,4	594,0	14,0	5,0	66,5	52,8
LH3244	BL1644	50,8	4 x 4	48,2	7,2	17,5	73,6	578,3	812,5	16,0	5,0	82,9	65,7
LH3246	BL1646	50,8	4 x 6	48,2	7,2	17,5	84,4	578,3	805,0	20,0	5,0	89,0	75,3
LH3266	BL1666	50,8	6 x 6	48,2	7,2	17,5	97,5	867,4	1170,0	24,0	5,0	112,2	94,6
LH3288	BL1688	50,8	8 x 8	48,2	7,2	17,5	127,5	1156,4	-	32,0	5,0	141,6	124,0
LH4022	BL2022	63,5	2 x 2	60,3	9,9	23,7	51,7	433,7	-	15,8	6,2	62,2	40,0
LH4023	BL2023	63,5	2 x 3	60,3	9,9	23,7	61,7	433,7	-	19,8	6,2	71,6	49,4
LH4034	BL2034	63,5	3 x 4	60,3	9,9	23,7	81,6	649,4	-	27,7	-	-	-
LH4044	BL2044	63,5	4 x 4	60,3	9,9	23,7	91,6	867,4	-	31,6	6,2	101,0	78,8
LH4046	BL2046	63,5	4 x 6	60,3	9,9	23,7	111,5	867,4	-	39,5	6,2	120,9	98,7
LH4066	BL2066	63,5	6 x 6	60,3	9,9	23,7	131,4	1301,1	-	47,4	6,2	143,3	120,6
LH4088	BL2088	63,5	8 x 8	60,3	9,9	23,7	171,2	1734,8	-	63,2	6,2	182,5	157,2

Zeichnung siehe Seite 104
 For drawing, see page 104



Flyerketten leichte Baureihe LL nach europäischer Norm

Leaf chains light series LL according to European standard ISO 4347/DIN 8152

Kettentyp Chain type	Teilung Pitch	Laschen- kombination Plate lacing	Laschenhöhe Plate depth	Laschendicke Plate thickness	Bolzen-Ø Pin Ø	Bolzenlänge Pin length	Min. Bruchkraft ISO/DIN Standard	Mittlere Bruchkraft	Gewicht pro Meter Weight per meter	Verbindungsbolzen Clevis pins			
							Min. tensile strengt h ISO/DIN	Avg. tensile strength		d1	d3	L1	x
DIN/ISO	p mm		h2 max. mm	T max. mm	d2 max. mm	b4 max. mm	FU kN	FB kN	q kg/m	d1 mm	d3 mm	L1 mm	x mm
LL0822	12,7	2 x 2	10,4	1,6	4,4	8,7	18,0	20,0	0,4	4,4	1,6	13,1	6,9
LL0844	12,7	4 x 4	10,4	1,6	4,4	15,4	36,0	39,6	0,8	4,4	1,6	20,1	13,7
LL0866	12,7	6 x 6	10,4	1,6	4,4	22,1	54,0	57,9	1,2	4,4	1,6	27,1	20,5
LL0888	12,7	8 x 8	10,4	1,6	4,4	29,3	72,8	84,0	1,6	4,4	1,6	34,0	27,4
LL1022	15,875	2 x 2	13,7	1,5	5,1	9,2	22,0	26,4	0,5	5,1	1,6	13,5	7,0
LL1044	15,875	4 x 4	13,7	1,5	5,1	15,8	44,0	52,6	1,1	5,1	1,6	20,1	14,0
LL1066	15,875	6 x 6	13,7	1,5	5,1	22,9	66,0	79,5	1,6	5,1	1,6	27,1	21,0
LL1088	15,875	8 x 8	13,7	1,5	5,1	28,1	90,8	102,6	2,1	5,1	1,6	34,1	28,0
LL1222	19,05	2 x 2	16,0	1,8	5,7	10,4	29,0	33,6	0,7	5,7	1,6	13,9	7,7
LL1244	19,05	4 x 4	16,0	1,8	5,7	17,9	58,0	71,3	1,4	5,7	1,6	21,7	15,3
LL1266	19,05	6 x 6	16,0	1,8	5,7	25,5	87,0	110,3	2,1	5,7	1,6	29,5	22,9
LL1288	19,05	8 x 8	16,0	1,8	5,7	33,1	115,6	149,0	2,8	5,7	1,3	37,9	31,2
LL1622	25,4	2 x 2	20,8	3,2	8,3	17,2	60,0	73,4	1,5	8,3	3,2	24,0	13,8
LL1644	25,4	4 x 4	20,8	3,2	8,3	30,5	120,0	159,8	2,9	8,3	3,2	37,0	27,4
LL1666	25,4	6 x 6	20,8	3,2	8,3	43,7	180,0	232,4	4,3	8,3	3,2	50,0	41,0
LL1688	25,4	8 x 8	20,8	3,2	8,3	56,5	232,0	281,3	5,7	8,3	3,2	63,0	54,6
LL2022	31,75	2 x 2	26,4	3,5	10,2	20,1	95,0	102,0	2,3	10,2	3,2	26,0	15,2
LL2044	31,75	4 x 4	26,4	3,5	10,2	32,8	190,0	219,7	4,4	10,2	3,2	41,0	30,3
LL2066	31,75	6 x 6	26,4	3,5	10,2	50,1	285,0	325,7	6,8	10,2	3,2	56,0	45,2
LL2088	31,75	8 x 8	26,4	3,5	10,2	64,0	380,0	444,8	8,9	10,2	3,2	71,0	60,2
LL2422	38,1	2 x 2	33,4	5,2	14,6	26,5	170,0	212,0	4,5	14,6	4,0	34,0	21,7
LL2444	38,1	4 x 4	33,4	5,2	14,6	48,6	340,0	448,0	8,2	14,6	4,0	56,3	43,2
LL2466	38,1	6 x 6	33,4	5,2	14,6	69,5	510,0	651,0	12,2	14,6	4,0	77,7	64,5
LL2488	38,1	8 x 8	33,4	5,2	14,6	86,6	680,0	801,0	16,3	14,6	4,0	99,1	86,0
LL2822	44,45	2 x 2	37,1	6,5	15,9	32,2	200,0	240,0	5,1	15,9	4,0	39,4	26,2
LL2844	44,45	4 x 4	37,1	6,5	15,9	56,4	400,0	518,0	9,9	15,9	4,0	65,2	52,0
LL2866	44,45	6 x 6	37,1	6,5	15,9	80,8	600,0	713,0	14,6	15,9	4,0	91,0	77,8
LL2888	44,45	8 x 8	37,1	6,5	15,9	105,2	800,0	916,0	19,4	15,9	4,0	116,4	103,6

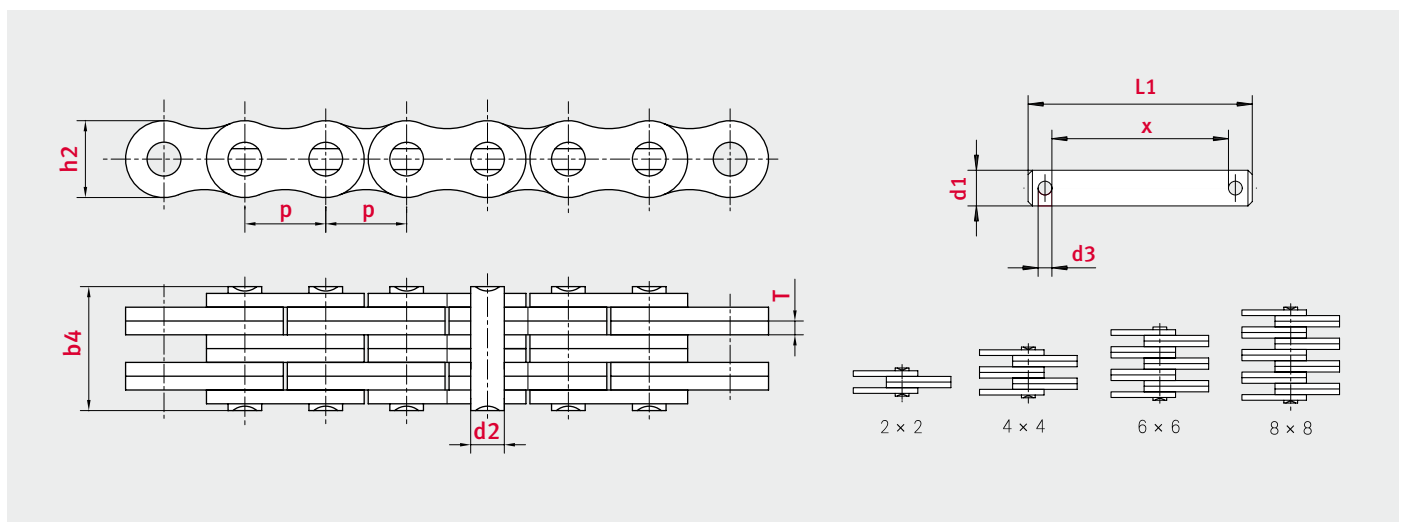



Flyerketten leichte Baureihe LL nach europäischer Norm

Leaf chains light series LL according to European standard ISO 4347/DIN 8152

Kettentyp	Teilung	Laschenkombination	Laschenhöhe	Laschendicke	Bolzen-Ø	Bolzenlänge	Min. Bruchkraft ISO/DIN Standard	Mittlere Bruchkraft	Gewicht pro Meter	Verbindungsbolzen			
Chain type	Pitch	Plate lacing	Plate depth	Plate thickness	Pin Ø	Pin length	Min. tensile strength ISO/DIN	Avg. tensile strength	Weight per meter	Clevis pins			
DIN/ISO	p mm		h2 max. mm	T max. mm	d2 max. mm	b4 max. mm	FU kN	FB kN	q kg/m	d1 mm	d3 mm	L1 mm	x mm
LL3222	50,8	2 x 2	42,0	6,5	17,8	34,8	260,0	304,6	6,2	17,8	5,0	46,6	27,7
LL3244	50,8	4 x 4	42,0	6,5	17,8	60,6	520,0	589,0	12,3	17,8	5,0	70,6	54,9
LL3266	50,8	6 x 6	42,0	6,5	17,8	87,2	780,0	870,0	18,3	17,8	5,0	97,6	82,1
LL3288	50,8	8 x 8	42,0	6,5	17,8	112,8	1040,0	-	24,0	17,8	5,0	124,6	109,3
LL4022	63,5	2 x 2	52,7	8,0	22,9	42,2	360,0	-	10,3	22,9	6,3	54,6	34,5
LL4044	63,5	4 x 4	52,7	8,0	22,9	74,4	720,0	-	20,0	22,9	6,3	88,5	68,5
LL4066	63,5	6 x 6	52,7	8,0	22,9	106,5	1080,0	1270,0	30,0	22,9	6,3	122,6	102,5
LL4088	63,5	8 x 8	52,7	8,0	22,9	140,0	1440,0	-	39,1	22,9	6,3	156,6	136,5
LL4822	76,2	2 x 2	63,9	10,3	29,2	54,6	560,0	-	18,5	-	-	-	-
LL4844	76,2	4 x 4	63,9	10,3	29,2	92,6	1120,0	-	35,7	-	-	-	-
LL4866	76,2	6 x 6	63,9	10,3	29,2	133,4	1680,0	-	53,0	-	-	-	-
LL4888	76,2	8 x 8	63,9	10,3	29,2	174,2	2240,0	-	70,4	-	-	-	-

Zeichnung siehe Seite 106
 For drawing, see page 106



Endlaschen für Flyerketten

Pear drop end links for Leaf chains

Kettentyp	Endlaschen				
Chain type	Pear drop end links				
	pe mm	d2 mm	ge mm	s max. mm	re mm
LL0822	15,00	6,00	16,00	1,60	10,00
LL0844	15,00	6,00	16,00	1,60	10,00
LL0866	15,00	6,00	16,00	1,60	10,00
LL1022	20,00	8,00	18,00	1,60	11,00
LL1044	20,00	8,00	18,00	1,60	11,00
LL1066	20,00	8,00	18,00	1,60	11,00
LL1088	20,00	8,00	18,00	1,60	11,00
LL1222	30,00	10,00	20,00	1,90	12,00
LL1244	30,00	10,00	20,00	1,90	12,00
LL1266	30,00	10,00	20,00	1,90	12,00
LL1622	30,00	12,00	25,00	3,00	15,00
LL1644	30,00	12,00	25,00	3,00	15,00
LL1666	30,00	12,00	25,00	3,00	15,00
LL1688	30,00	12,00	25,00	3,00	15,00
LL2022	50,00	18,00	40,00	3,50	25,00
LL2044	50,00	18,00	40,00	3,50	25,00
LL2066	50,00	18,00	40,00	3,50	25,00
LL2088	50,00	18,00	40,00	3,50	25,00

Kettentyp	Endlaschen				
Chain type	Pear drop end links				
	pe mm	d2 mm	ge mm	s max. mm	re mm
LL2422	65,00	24,00	50,00	5,00	29,00
LL2444	65,00	24,00	50,00	5,00	29,00
LL2466	65,00	24,00	50,00	5,00	29,00
LL2488	65,00	24,00	50,00	5,00	29,00
LL2822	80,00	28,00	60,00	6,00	32,00
LL2844	80,00	28,00	60,00	6,00	32,00
LL2866	80,00	28,00	60,00	6,00	32,00
LL2888	80,00	28,00	60,00	6,00	32,00
LL3222	90,00	32,00	70,00	6,30	43,00
LL3244	90,00	32,00	70,00	6,30	43,00
LL3266	90,00	32,00	70,00	6,30	43,00
LL3288	90,00	32,00	70,00	6,30	43,00
LL4022	100,00	38,00	80,00	8,00	46,50
LL4044	100,00	38,00	80,00	8,00	46,50
LL4066	100,00	38,00	80,00	8,00	46,50
LL4088	100,00	38,00	80,00	8,00	46,50

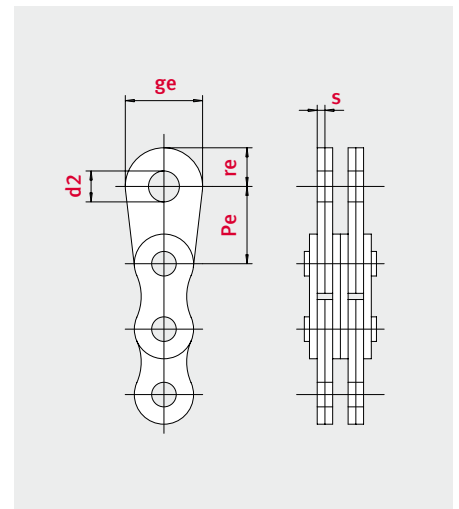

Umlenkrollen: bmin= Gesamtbreite der Kette (B x 1,05)
 Idler wheel: bmin= overall width of chain (B x 1.05)



ELITE® Flyerketten Baureihe AL
Leaf chains AL series

Kettentyp	Teilung	Laschen- kombination	Laschenhöhe	Laschendicke	Bolzen-Ø	Bolzenlänge	Min. Bruchkraft ISO/DIN Standard	Gewicht pro Meter	Verbindungsbolzen			
Chain type	Pitch	Plate lacing	Plate depth	Plate thickness	Pin Ø	Pin length	Min. tensile strength ISO/DIN	Weight per meter	Clevis pins			
ANSI	p mm		h2 max. mm	T max. mm	d2 max. mm	b4 max. mm	FU kN	q kg/m	d1 mm	d3 mm	L1 mm	x mm
AL322	9,525	2 X 2	7,3	1,3	3,58	8,9	8,5	0,23	-	-	-	-
AL344	9,525	4 X 4	7,3	1,3	3,58	11,6	17	0,46	-	-	-	-
AL422	12,7	2 X 2	10,4	1,5	3,96	8,1	13,9	0,39	3,96	1,6	12,75	6,5
AL444	12,7	4 X 4	10,4	1,5	3,96	14,4	27,8	0,74	3,96	1,6	19,35	12,9
AL466	12,7	6 X 6	10,4	1,5	3,96	20,6	41,7	1,13	3,96	1,6	25,95	19,3
AL522	15,875	2 X 2	13	2	5,08	10,7	21,8	0,64	5,07	1,6	14,63	8,5
AL534	15,875	3 X 4	13	2	5,08	17	33	1,1	5,07	1,6	21	15,1
AL544	15,875	4 X 4	13	2	5,08	19,3	43,6	1,25	5,07	1,6	23,11	16,8
AL566	15,875	6 X 6	13	2	5,08	27,9	65,4	1,79	5,07	1,6	31,59	25
AL622	19,05	2 X 2	15,6	2,4	5,94	12,9	31,3	0,86	5,07	1,6	19,4	12,8
AL644	19,05	4 X 4	15,6	2,4	5,94	22,9	62,6	1,76	5,91	2	27,32	21,32
AL666	19,05	6 X 6	15,6	2,4	5,94	33,1	93,9	2,6	5,91	2	37,68	31,88
AL688	19,05	8 X 8	15,6	2,4	5,94	43,2	125,2	3,49	5,91	2	49,3	42,5
AL822	25,4	2 X 2	20,8	3,2	7,92	16	55,6	1,54	7,92	3,2	24,15	13,55
AL844	25,4	4 X 4	20,8	3,2	7,92	29,8	111,2	3	7,92	3,2	37,4	26,6
AL866	25,4	6 X 6	20,8	3,2	7,92	43,1	166,8	4,46	7,92	3,2	50,6	39,8

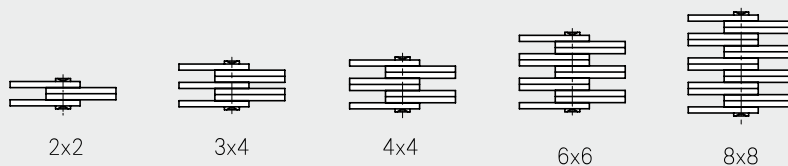
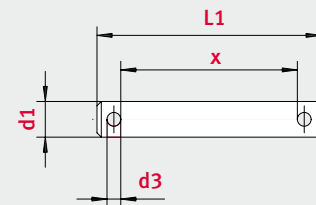
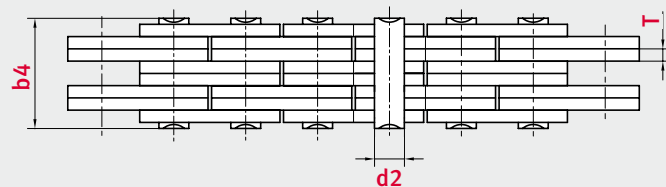
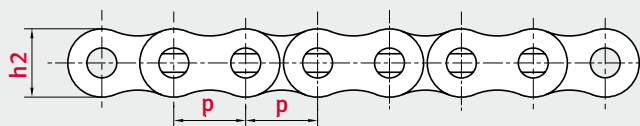



iwis Customer Service

CallBack +49 2739 86-0 -22

sales-wilnsdorf@iwis.com



Flyerketten Baureihe AL

Leaf chains AL series

Kettentyp	Teilung	Laschen- kombination	Laschenhöhe	Laschendicke	Bolzen-Ø	Bolzenlänge	Min. Bruchkraft ISO/DIN Standard	Gewicht pro Meter	Verbindungsbolzen			
Chain type	Pitch	Plate lacing	Plate depth	Plate thickness	Pin Ø	Pin length	Min. tensile strength ISO/DIN	Weight per meter	Clevis pins			
ANSI	p mm		h2 max. mm	T max. mm	d2 max. mm	b4 max. mm	FU kN	q kg/m	d1 mm	d3 mm	L1 mm	x mm
AL1022	31,75	2 X 2	26	4	9,53	19,6	87	2,37	9,51	3,2	28,8	18,3
AL1044	31,75	4 X 4	26	4	9,53	37,3	174	4,68	9,51	3,2	45,58	34,78
AL1066	31,75	6 X 6	26	4	9,53	53,8	261	7,2	9,51	3,2	63,7	52,2
AL1088	31,75	8 X 8	26	4	9,53	69,9	348	9,94	9,51	3,2	80,3	69
AL1222	38,1	2 X 2	31,2	4,8	11,1	24,3	125	3,65	11,09	4	34,4	21,1
AL1244	38,1	4 X 4	31,2	4,8	11,1	43,8	250	7,05	11,09	4	54,99	41,4
AL1266	38,1	6 X 6	31,2	4,8	11,1	64,7	375	10,5	11,09	4	75,71	62
AL1288	38,1	8 X 8	31,2	4,8	11,1	82,6	500	14,03	11,09	4	92,4	79,9
AL1444	44,45	4 X 4	36,4	5,6	12,64	51,3	340	10,34	12,67	4	61,23	48,03
AL1466	44,45	6 X 6	36,4	5,6	12,64	74,6	510	15,16	12,67	4	85,07	71,87
AL1644	50,8	4 X 4	41,6	6,5	14,21	58	446	12,98	14,22	4	71,69	55,5
AL1666	50,8	6 X 6	41,6	6,5	14,21	85,5	669	19,76	14,22	4	98,6	83,01
AL1688	50,8	8 X 8	41,6	6,5	14,21	109,5	892	25,47	14,22	4	126,9	111,6

Zeichnung siehe Seite 108
 For drawing, see page 108



ELITE® Sonder-Flyerketten mit Schlauchführungen und Hydraulikmastschutz für Gabelstapler

Special leaf chains with tube guides for forklifts

Flyerketten mit außenliegenden Schlauchführungen in Kunststoff werden als Lastketten überwiegend in Gabelstaplern eingesetzt. Die Kunststoffflaschen sind meistens außenliegend auf dem Bolzen montiert und bewirken, dass beim unvermeidlichen Schwingen oder Verkanten der Kette nicht die Kettenglieder, sondern die vorspringenden Kunststoffflaschen gegen die Kolbenstange des Hydraulikzylinders schlagen. So wird weder der Kette noch den Hydraulikaggregaten Schaden zugefügt. Alternativ zu den außenliegenden Kunststoffflaschen werden diese Kunststoffabdeckungen auch als innenliegende T-, U- oder L-förmige Abdeckungen angeboten.

Highlights der ELITE Flyerketten

- Höhere Dauerfestigkeit durch verbesserten Preßsitz von Bolzen und Außenlasche
- Höhere Bruchkraft durch optimierte Laschenstärke
- Höhere Verschleißfestigkeit durch höhere Oberflächenhärte am Bolzen
- Hohe Passgenauigkeit durch Eingrenzung der Toleranzen bei Verwendung von Kaltband für alle Kettenlaschen

TYP LL1266 KS



Art.-Nr.: 81013799

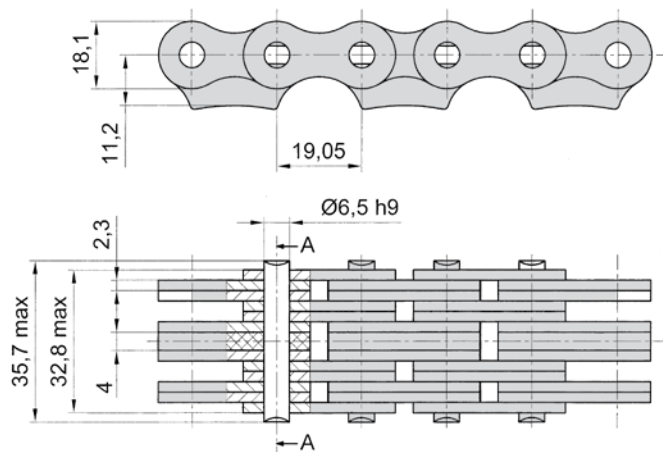
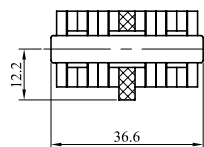

TYP LL1644 KS105



Art.-Nr.: 81013552

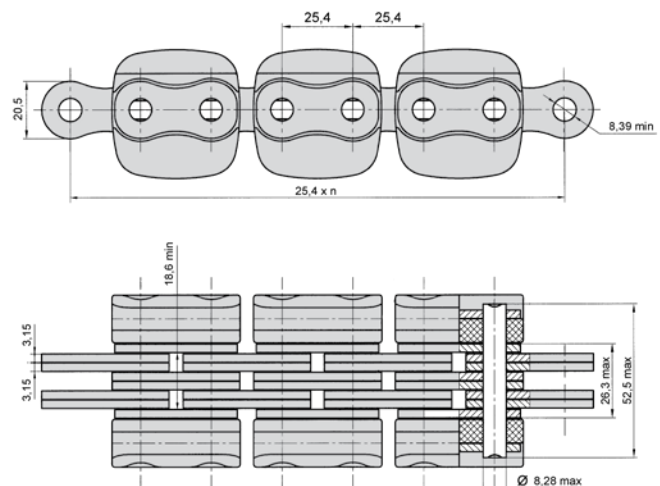
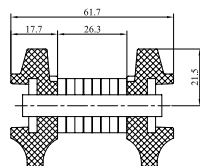



Sonder-Flyerketten mit Schlauchführungen und Hydraulikmastschutz für Gabelstapler

Special leaf chains with tube guides for forklifts

Leaf chains with externally positioned plastic tube guides are generally used in forklifts as load chains. The plastic link plates are usually mounted on the outside of the pins and have the following effect: When the unavoidable vibration or jamming of the chain occurs, not the chain links will hit the piston rod of the hydraulic cylinder, but the protruding plastic link plates. This means that neither chain nor aggregates are damaged. The plastic coverings are also available as inside-positioned, T-U- or L-formed coverings.

Highlights of the **ELITE** leaf chains

- Higher fatigue strength due to optimized press fit of pin and outer link plate
- Higher tensile strength due to optimized plate strength
- Higher wear resistance due to higher surface hardness of the pins
- High fitting accuracy due to limiting the tolerances when using cold rolled strips for all link plates

TYP LL1644 KS103



Art.-Nr.: 81013553

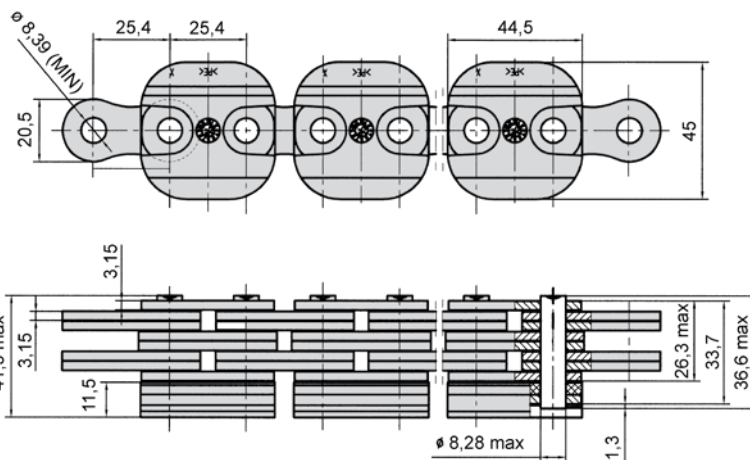
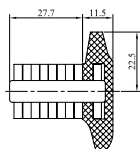

TYP LL1666 KS106



Art.-Nr.: 81013554

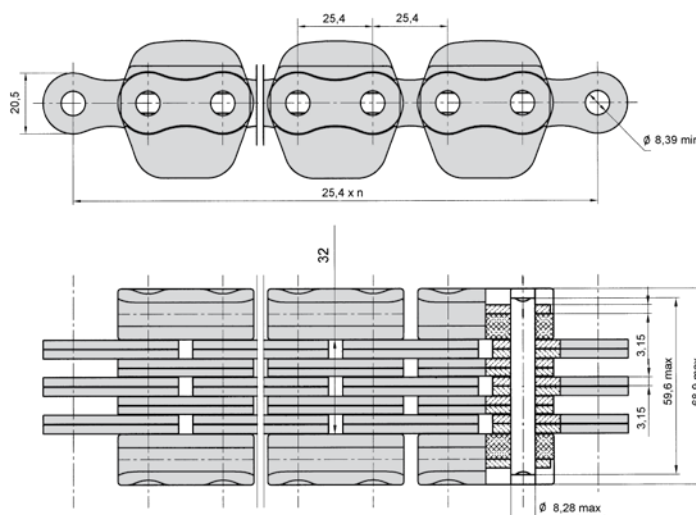
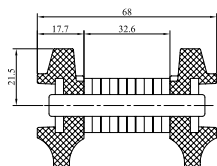



ELITE® Sonder-Flyerketten mit Schlauchführungen
und Hydraulikmastschutz für Gabelstapler
Special leaf chains with tube guides for forklifts

TYP BL633 KS



Art.-Nr.: 81013550

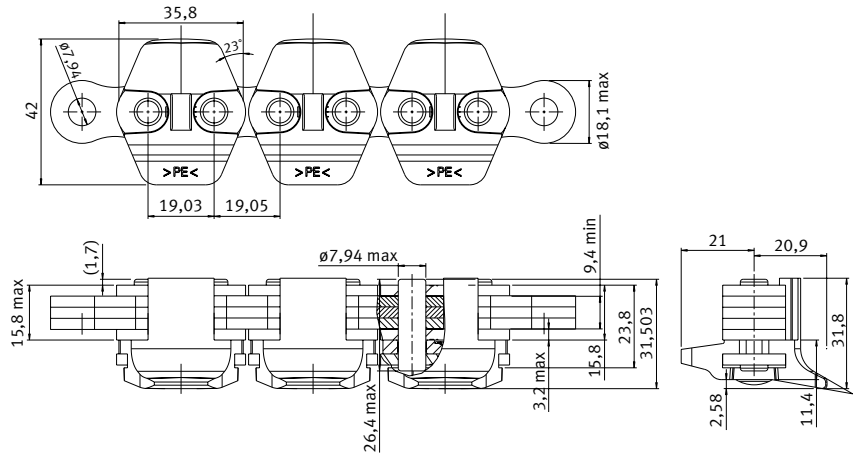

TYP BL844 LKS



Art.-Nr.: 81013821

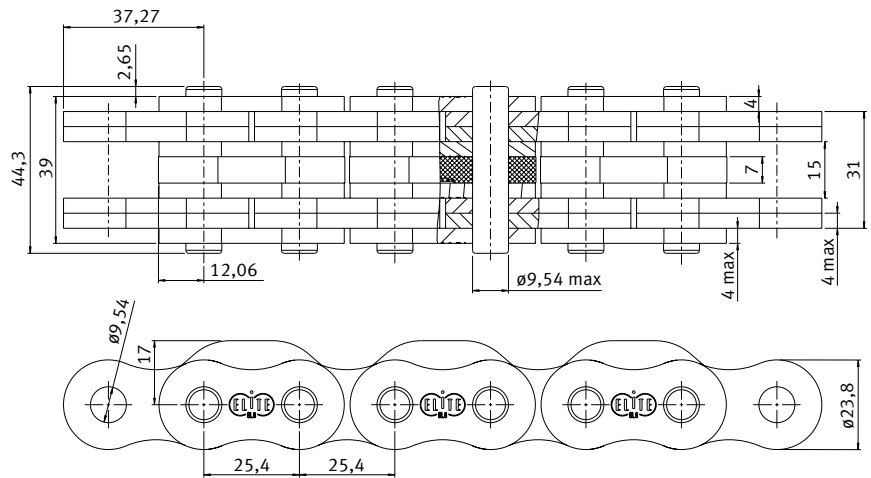

TYP BL 844 KS109



Art.-Nr.: 81012723

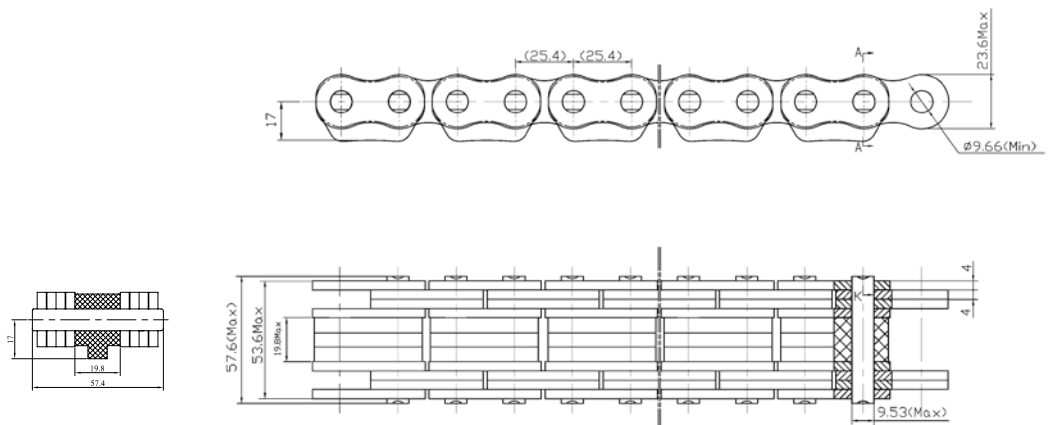



iwis Customer Service

CallBack ☎ +49 2739 86-0 🖨 -22

✉ sales-wilnsdorf@iwis.com



Sonder-Flyerketten mit Schlauchführungen und Hydraulikmastschutz für Gabelstapler

Special leaf chains with tube guides for forklifts

TYP BL 844 KS116



Art.-Nr.: 81012722

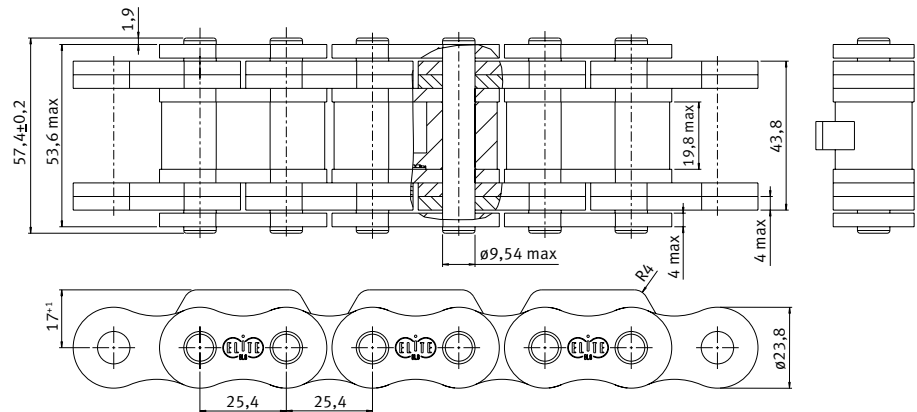

TYP BL866 KS102



Art.-Nr.: 81012415

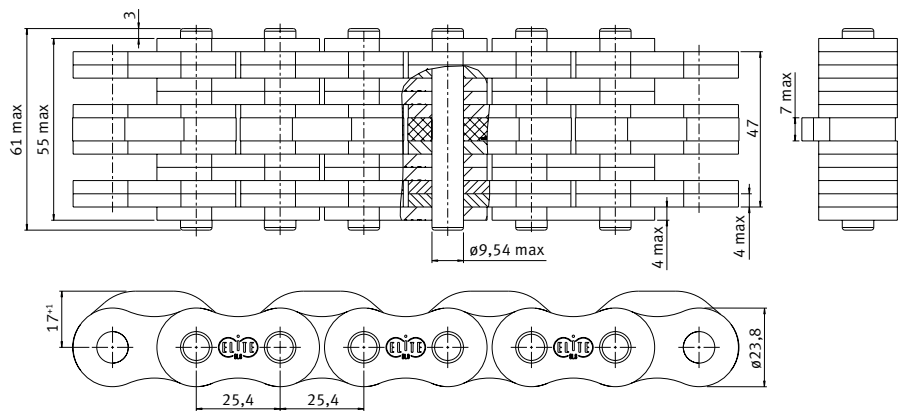

TYP BL866 KS104



Art.-Nr.: 81013551

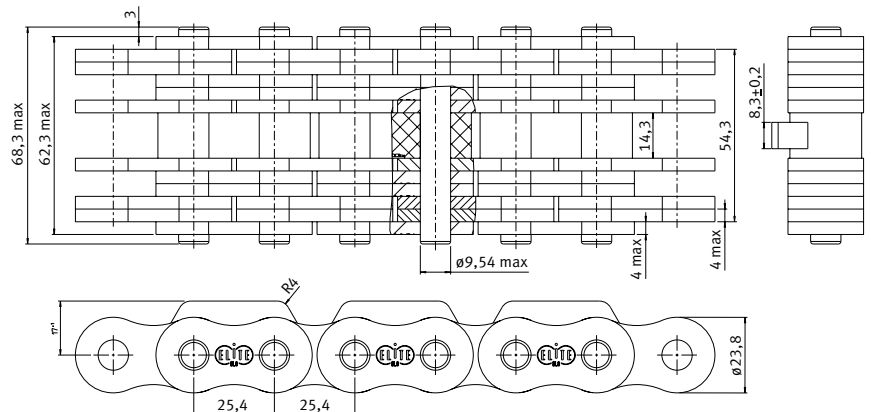



**Sonder-Flyerketten mit Schlauchführungen
und Hydraulikmastschutz für Gabelstapler**

Special leaf chains with tube guides for forklifts

TYP BL866 KS111



Art.-Nr.: 81012399

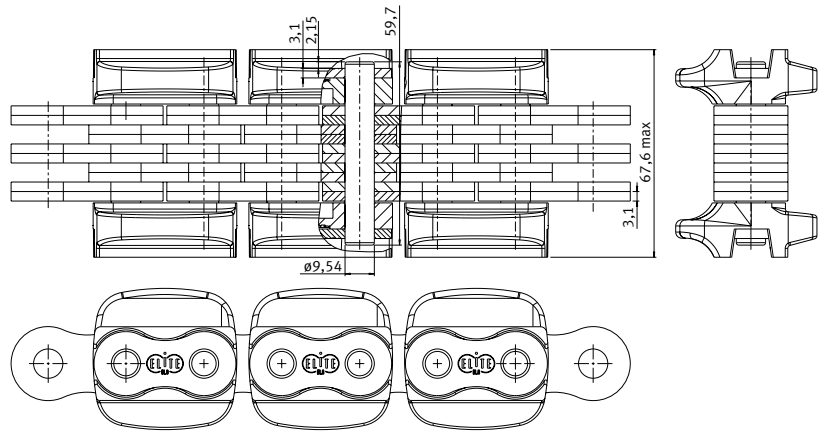

TYP BL888 KS



Art.-Nr.: 81012391

